

HIWIN®

Motion Control & Systems



Linear Guideways



Ballscrews



Positioning Systems

HIWIN Compact

Welcome to HIWIN

HIWIN offers a complete range of linear technology products. Our Compact Catalog provides an overview of our standard range, in stock and ready for delivery.

HIWIN Compact

Contents

1. Linear Guideways	6
1.1 Product Overview	6
1.2 Linear Guideway Series HG	8
1.3 Linear Guideway Series EG	22
1.4 Linear Guideway Series QH/QE	34
1.5 Linear Guideway Series WE	48
1.6 Linear Guideway Series MG	59
1.7 Linear Guideway Series RG	70
1.8 Accessory	84
2. Ballscrews	89
2.1 Product Overview	89
2.2 Rolled Ballscrews	92
2.3 Peeled Ballscrews	96
2.4 Accessory	104
3. Positioning Systems	117
3.1 Linear Axes KK	117

Linear Guideways

Product Overview

1. Linear Guideways

A linear guideway facilitates linear movement using ball bearings. Thanks to the use of ball bearings between the rail and the block, it is possible for a linear guideway to achieve extremely precise linear movement. In comparison with a conventional guide rail, the friction coefficient is only one fiftieth. Due to the restricted guidance of the block on the rail the linear guideway can carry loads in vertical and horizontal directions.

1.1 Product Overview

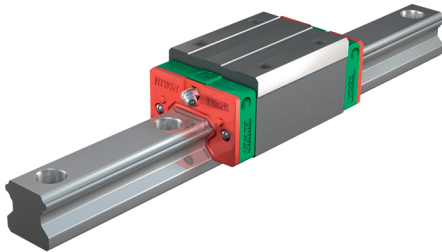

Linear Guideway Series HG

Page 8

- 4-row recirculating ball bearing guide
- 45° contact angle of the ball tracks
- High load capacity in all installation positions
- High rigidity

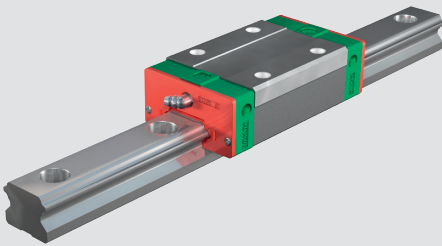

Linear Guideway Series EG

Page 22

- 4-row recirculating ball bearing guide
- 45° contact angle of the ball tracks
- High load capacity in all installation positions
- Low assembly height

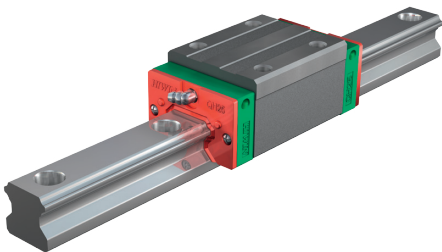

Linear Guideway Series QH/QE

Page 34

- Block with SynchMotion™-Technology
- Smooth movement
- Optimal synchronous run
- Usable on standard HG- and EG-rails
- Interchangeable with standard blocks

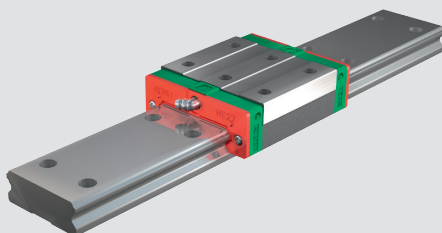

Linear Guideway Series WE

Page 48

- 4-row recirculating ball bearing guide
- 45° contact angle of the ball tracks
- High torque capacity
- Low assembly height

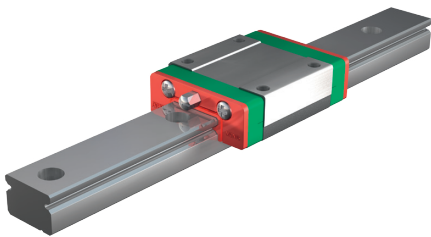

Linear Guideway Series MG

Page 59

- 2-row recirculating ball bearing guide
- 45° contact angle of the ball tracks
- Compact design
- Small and wide rails

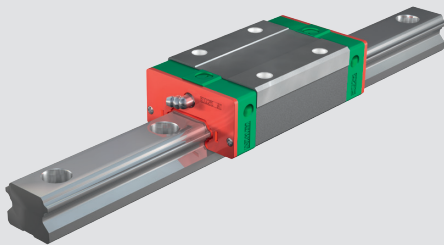

Linear Guideway Series RG

Page 70

- 4-row recirculating roller bearing guide
- 45° contact angle of the ball tracks
- Recirculation roller guide
- Very high load capacity
- Very high rigidity

Accessory

Page 84

- Grease Nipple
- Lubrication Adapter
- Push-in Fitting

Linear Guideways

HG series

1.2 Linear Guideway Series HG

1.2.1 Special characteristics of the linear guideway series HG

The HIWIN linear guideways of the HG series with four ball tracks are designed for loads and a rigidity that is more than 30 % higher than for similar products. This is due to the optimization of the ball track and the recirculating ball system. Low friction forces and high efficiency are additional features of the HG series. The ball retainers prevent the balls from falling out when pulled from the rail during installation of the carriages.

1.2.2 Construction of the HG series

- 4-row recirculating ball bearing guide
- 45° contact angle of the ball tracks
- The ball retainers prevent the balls from falling out when the carriage is removed
- Different sealing variants, depending on application area
- Six connection options for grease nipples or grease adapters

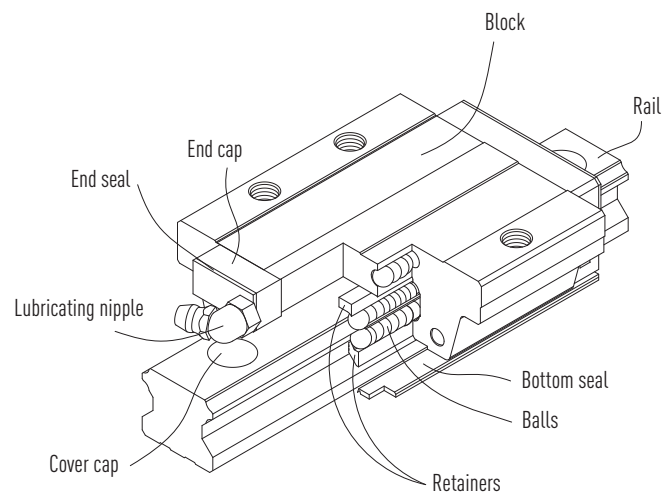

Fig. Construction of the HG series

1.2.3 Advantages

- Free of play
- Replaceable
- High precision
- High load ratings and rigidity in all directions
- Low friction losses even with preload by optimized ball tracks and 2-point contact

1.2.4 Article numbers for the HG series

Linear guideways are available as either interchangeable or non-interchangeable versions. The dimensions of both models are identical. The interchangeable models are more user friendly, as the block and rail can be replaced freely. However, accuracy is lower than that of the non-interchangeable models. Due to the strict control of dimensional accuracy, the interchangeable models are a good choice for customers not using pairs of rails on a stage. The article numbers include the dimensions, model, accuracy class and preload class etc.

1.2.4.1 Non-interchangeable models (customized models)

○ Item number of the fully installed linear guideway

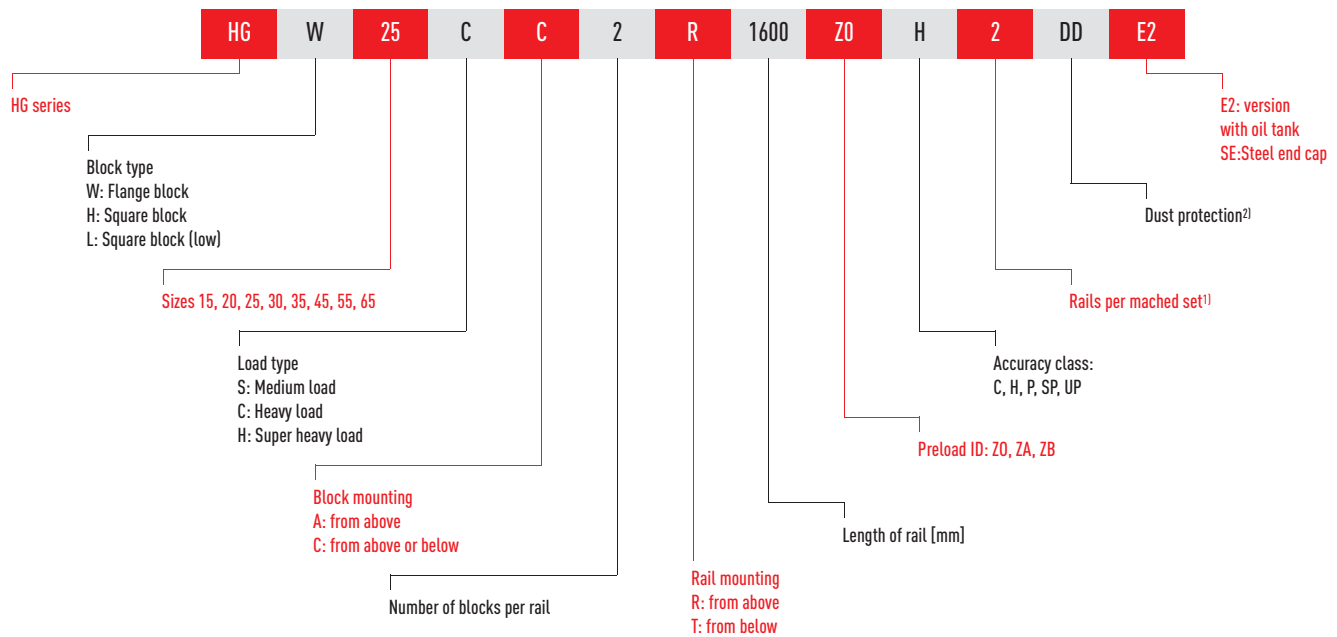

1.2.4.2 Interchangeable models

○ Article number of the HG block

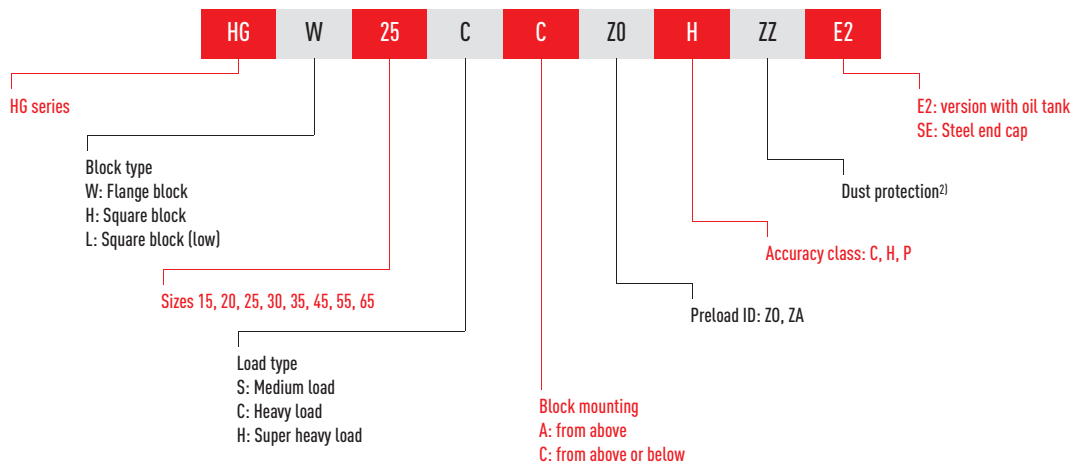

○ Article number of the HG rail

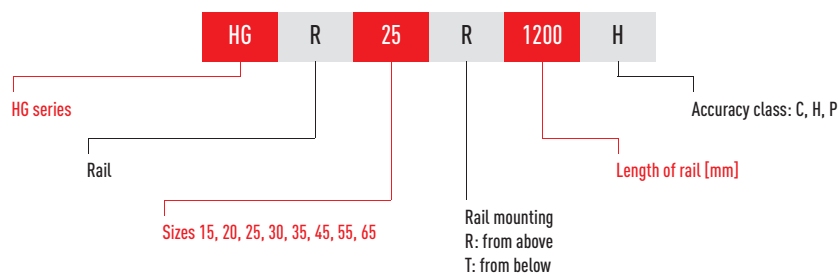

Note:

- Figure 2 is also a quantity statement, i.e. a part of the article described above consists of a pair of rails. No figures are provided for individual linear guideways.
- No information is provided for the standard version for dust protection (end seal and bottom seal)
 ZZ: End seal, bottom seal and scraper
 KK: Double seals, bottom seal and scraper
 DD: Double seals and bottom seal
 SW: Special seal for applications in very heavily contaminated environment

Linear Guideways

HG series

1.2.5 Block types

HIWIN offers square blocks and flange blocks for its linear guideways. The low assembly height and larger installation surface makes flange blocks more suitable for heavy loads.

Table 1.1 Block types

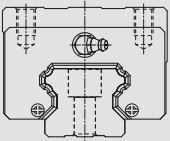
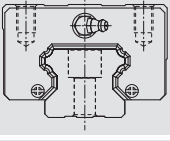
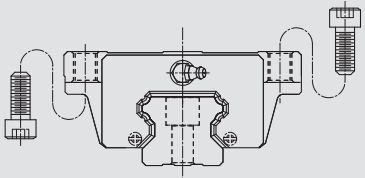
Type	Series Size	Construction	Height [mm]	Rail length [mm]	Typical application
High block design	HGH-CA HGH-HA		28 – 90	100 – 4.000	<ul style="list-style-type: none"> ○ Machining centers ○ NC lathes ○ Grinders ○ Precision milling ○ High-performance cutting machinery ○ Automation technology ○ Transportation technology ○ Measuring technology ○ Machines and devices requiring a high level of positioning accuracy
Low block design	HGL-CA HGL-HA		24 – 70		
Flange	HGW-CC HGW-HC		24 – 90		

1.2.6 Preload

1.2.6.1 Definition

A preload can be applied to any rail version. For this purpose, oversized balls are used. Normally a linear guideway has a negative clearance between the path and the ball bearings, to increase rigidity and precision. The curve shows that rigidity doubles with a high preload. A preload not larger than ZA would be recommended for all model sizes under HG20 to avoid a reduction of service life.

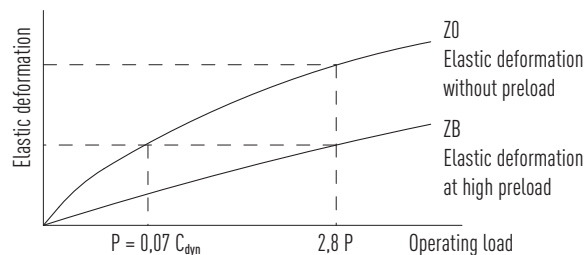

1.2.6.2 Preload ID

Table 1.2 Preload ID

ID	Preload		Application	Example applications
Z0	Light preload	0 – 0,02 C_{dyn}	Constant load direction, low impacts, low accuracy required	Transportation technology, automatic packaging machinery, X-Y stages for industrial machinery, automated welding machinery
ZA	Medium preload	0,05 – 0,07 C_{dyn}	High accuracy required	Machining centers, Z stages for industrial machinery, erosion machinery, NC lathes, precision X-Y benches, measuring technology
ZB	High preload	above 0,1 C	High rigidity required, with vibrations and impacts	Machining centers, grinding machinery, NC lathes, horizontal and vertical milling machinery, Z stage of machine tools, high-performance cutting machinery

Note:

Preload classes for interchangeable versions Z0 and ZA. For non-interchangeable versions: Z0, ZA, ZB.

1.2.7 Accuracy classes

The HG series is divided into five classes according to respective accuracy – normal (C), high (H), precision class (P), super precision class (SP) and ultra precision class (UP). The requirements of the machinery in which the linear guideway is used, determine the selection.

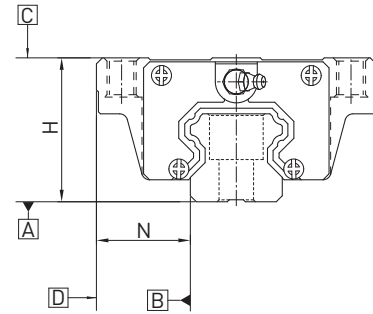

1.2.7.1 Accuracy classes of non-interchangeable types

Parallelism of block surface C with surface A, see table 1.5

Parallelism of block surface D with surface B, see table 1.5

Table 1.3 Tolerances depending on the accuracy class

Series/Size	Accuracy class	Height tolerance of H ¹⁾	Width tolerance of N ¹⁾	Height variance of H ²⁾	Width variance of N ²⁾
HG_15, 20	Normal (C)	± 0,1	± 0,1	0,02	0,02
	High (H)	± 0,03	± 0,03	0,01	0,01
	Precision (P)	0 - 0,03	0 - 0,03	0,006	0,006
	Super precision (SP)	0 - 0,015	0 - 0,015	0,004	0,004
	Ultra precision (UP)	0 - 0,008	0 - 0,008	0,003	0,003
HG_25, 30, 35	Normal (C)	± 0,1	± 0,1	0,02	0,03
	High (H)	± 0,04	± 0,04	0,015	0,015
	Precision (P)	0 - 0,04	0 - 0,04	0,007	0,007
	Super precision (SP)	0 - 0,02	0 - 0,02	0,005	0,005
	Ultra precision (UP)	0 - 0,01	0 - 0,01	0,003	0,003
HG_45, 55	Normal (C)	± 0,1	± 0,1	0,03	0,03
	High (H)	± 0,05	± 0,05	0,015	0,02
	Precision (P)	0 - 0,05	0 - 0,05	0,007	0,01
	Super precision (SP)	0 - 0,03	0 - 0,03	0,005	0,007
	Ultra precision (UP)	0 - 0,02	0 - 0,02	0,003	0,005
HG_65	Normal (C)	± 0,1	± 0,1	0,03	0,03
	High (H)	± 0,07	± 0,07	0,02	0,025
	Precision (P)	0 - 0,07	0 - 0,07	0,01	0,015
	Super precision (SP)	0 - 0,05	0 - 0,05	0,007	0,01
	Ultra precision (UP)	0 - 0,03	0 - 0,03	0,005	0,007

Unit: mm

¹⁾ Tolerance data that applies to any rail with any block

²⁾ Permissible absolute dimensional deviation between several blocks distributed over one individual rail or located on a pair of rails

Linear Guideways

HG series

1.2.7.2 Accuracy classes of interchangeable types

Parallelism of block surface C with surface A, see table 1.5

Parallelism of block surface D with surface B, see table 1.5

Table 1.4 Tolerances depending on the accuracy class

Series/Size	Accuracy class	Height tolerance of H ¹⁾	Width tolerance of N ¹⁾	Height variance of H ²⁾	Width variance of N ²⁾
HG_15, 20	Normal (C)	± 0,1	± 0,1	0,02	0,02
	High (H)	± 0,03	± 0,03	0,01	0,01
	Precision (P)	± 0,015	± 0,015	0,006	0,006
HG_25, 30, 35	Normal (C)	± 0,1	± 0,1	0,02	0,03
	High (H)	± 0,04	± 0,04	0,015	0,015
	Precision (P)	± 0,02	± 0,02	0,007	0,007
HG_45, 55	Normal (C)	± 0,1	± 0,1	0,03	0,03
	High (H)	± 0,05	± 0,05	0,015	0,02
	Precision (P)	± 0,025	± 0,025	0,007	0,01
HG_65	Normal (C)	± 0,1	± 0,1	0,03	0,03
	High (H)	± 0,07	± 0,07	0,02	0,025
	Precision (P)	± 0,035	± 0,035	0,01	0,015

Unit: mm

¹⁾ Tolerance data that applies to any block on any rail

²⁾ Permissible absolute dimensional deviation between several blocks, distributed over one individual rail or located on a pair of rails

Table 1.5 Tolerance parallelism between block and rail

Rail length [mm]	Accuracy class				
	C	H	P	SP	UP
– 100	12	7	3	2	2
100 – 200	14	9	4	2	2
200 – 300	15	10	5	3	2
300 – 500	17	12	6	3	2
500 – 700	20	13	7	4	2
700 – 900	22	15	8	5	3
900 – 1100	24	16	9	6	3
1100 – 1500	26	18	11	7	4
1500 – 1900	28	20	13	8	4
1900 – 2500	31	22	15	10	5
2500 – 3100	33	25	18	11	6
3100 – 3600	36	27	20	14	7
3600 – 4000	37	28	21	15	7

Unit: µm

1.2.8 Dust protection

A variety of sealing systems are available for the HIWIN sliding carriage. You will find an overview of these on page 87. In the following table, the overall lengths of the sliding carriages with different sealing systems are listed. The corresponding sealing systems are available for these design sizes.

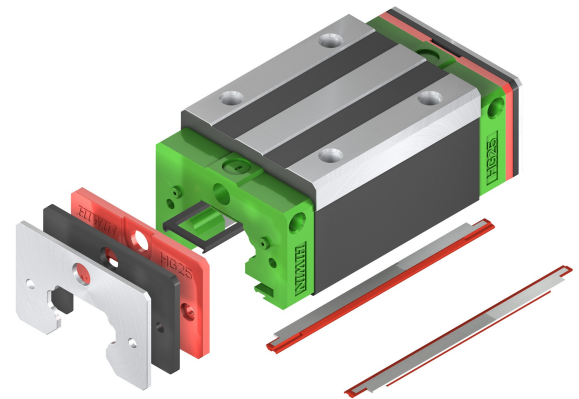
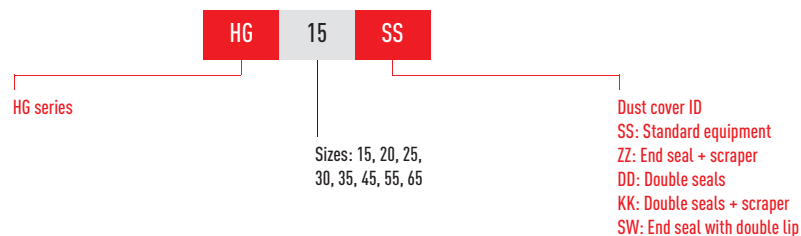

Table 1.6 The overall length of the sliding carriage with different sealing systems

Series Size	Gesamtlänge L					
	SS	DD	ZZ	KK	SW	ZWX
HG_15C	61,4	68,0	69,0	75,6	63,2	-
HG_20C	77,5	82,5	82,5	87,5	78,5	82,3
HG_20H	92,2	97,5	97,2	102,2	93,2	97,0
HG_25C	84,0	89,0	89,0	94,0	85,0	91,8
HG_25H	104,6	109,6	109,6	114,6	105,6	112,4
HG_30C	97,4	104,8	105,4	112,8	99,0	105,8
HG_30H	120,4	127,8	128,4	135,8	122,0	128,8
HG_35C	112,4	119,8	120,4	127,8	115,2	122,4
HG_35H	138,2	145,6	146,2	153,6	141,0	148,2
HG_45C	139,4	149,4	150,0	160,0	140,0	144,8
HG_45H	171,2	181,2	181,8	191,8	171,8	176,6
HG_55C	166,7	177,1	177,1	187,5	163,7	172,9
HG_55H	204,8	215,2	215,2	225,5	201,8	211,0
HG_65C	200,2	209,2	208,2	217,2	196,2	203,4
HG_65H	259,6	268,6	267,6	276,6	255,6	262,8

1.2.8.1 Designation of the seal sets

The seal sets are always shipped complete with the installation materials and include the supplemental parts for the standard seal.



Linear Guideways

HG series

1.2.9 Friction

The table shows the maximum frictional resistance of the single endseal. Depending on the seal arrangement (SS, ZZ, DD, KK), the value has to be multiplied accordingly. The specified values apply to blocks on uncoated rails. Higher frictional forces occur on coated rails.

Table 1.8 Frictional resistance of the single-lip seals

Series/Size	Resistance [N]	Series/Size	Resistance [N]
HG_15	1,2	HG_35	3,1
HG_20	1,6	HG_45	3,9
HG_25	2,0	HG_55	4,7
HG_30	2,7	HG_65	5,8

1.2.10 The accuracy tolerance of rail-mounting surface

Because of the circular-arc contact design, the HG linear guideway can compensate for some surface-error on installation and still maintain smooth linear motion. As long as the accuracy requirements for the mounting surface are followed, high accuracy and rigidity of linear motion of the guideway can be obtained without any difficulty. In order to satisfy the needs of fast installation and smooth movement, HIWIN offers the normal clearance type of preload to customers of its high absorption ability of the deviation in mounting surface accuracy.

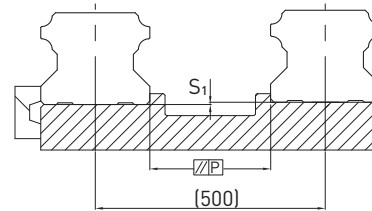

Parallelism tolerance of reference surface (P)

Table 1.9 Maximum tolerances for the parallel alignment (P)

Series/Size	Load class		
	Z0	ZA	ZB
HG_15	25	18	—
HG_20	25	20	18
HG_25	30	22	20
HG_30	40	30	27
HG_35	50	35	30
HG_45	60	40	35
HG_55	70	50	45
HG_65	80	60	55

Unit: μm

Table 1.10 Maximum tolerance of reference surface height (S₁)

Series/Size	Load class		
	Z0	ZA	ZB
HG_15	130	85	—
HG_20	130	85	50
HG_25	130	85	70
HG_30	170	110	90
HG_35	210	150	120
HG_45	250	170	140
HG_55	300	210	170
HG_65	350	250	200

Unit: μm

1.2.11 Shoulder heights and fillets

Improper shoulder heights and fillets of mounting surfaces will cause a deviation in accuracy and the interference with the chamfered part of the rail or block. As long as the recommended shoulder heights and fillets are followed, installation inaccuracies should be eliminated.

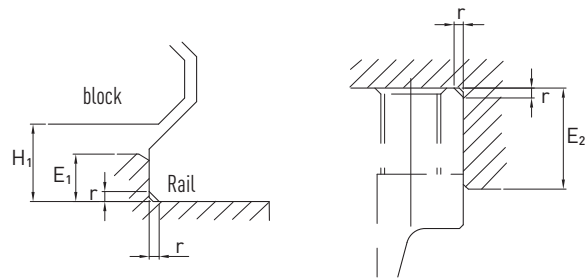

Table 1.11 Shoulder heights and fillets

Series/Size	Max. radius of fillets r	Shoulder height of the rail E ₁	Shoulder height of the block E ₂	Clearance under block H ₁
HG_15	0,5	3,0	4,0	4,3
HG_20	0,5	3,5	5,0	4,6
HG_25	1,0	5,0	5,0	5,5
HG_30	1,0	5,0	5,0	6,0
HG_35	1,0	6,0	6,0	7,5
HG_45	1,0	8,0	8,0	9,5
HG_55	1,5	10,0	10,0	13,0
HG_65	1,5	10,0	10,0	15,0

Unit: mm

Linear Guideways

HG series

1.2.12 Load ratings and torques

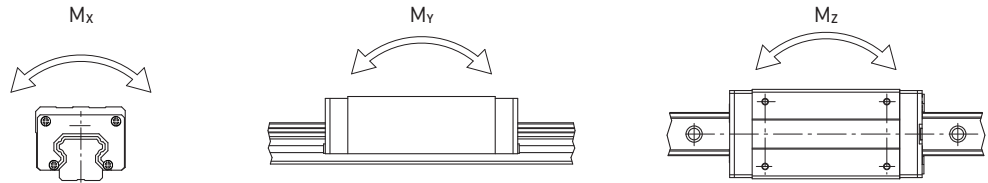

Table 1.12 Load ratings and torques series HG

Series/Size	Dynamic load C_{dyn} [N]*	Static load C_0 [N]	Dynamic moment [Nm]			Static moment [Nm]		
			M_x	M_y	M_z	M_{0x}	M_{0y}	M_{0z}
HG_15C	11380	16970	76	67	67	120	100	100
HG_20C	17750	27760	178	126	126	270	200	200
HG_20H	21180	35900	208	203	203	350	350	350
HG_25C	26480	36490	301	240	240	420	330	330
HG_25H	32750	49440	374	379	379	560	570	570
HG_30C	38740	52190	494	396	396	660	530	530
HG_30H	47270	69160	600	630	630	880	920	920
HG_35C	49520	69160	832	577	577	1160	810	810
HG_35H	60210	91630	1011	918	918	1540	1400	1400
HG_45C	77570	102710	1497	1169	1169	1980	1550	1550
HG_45H	94540	136460	1825	1857	1857	2630	2680	2680
HG_55C	114440	148330	2843	2039	2039	3690	2640	2640
HG_55H	139350	196200	3464	3242	3242	4880	4570	4570
HG_65C	163630	215330	5049	3245	3245	6650	4270	4270
HG_65H	208360	303130	6449	5068	5068	9380	7380	7380

* Dynamic load rating for 50,000 m travel path

1.2.13 Rigidity

Rigidity is dependent on the preload. Using formula 1.1, it is possible to determine the deformation in relation to the rigidity.

$$\delta = \frac{P}{k}$$

δ : deformation [μm]
 P : Operating load [N]
 k : Rigidity value [N/ μm]

Formula 1.1

Table 1.13 Radial rigidity series HG

Load class	Series Size	Preload		
		Z0	ZA	ZB
Heavy load	HG_15C	200	260	290
	HG_20C	250	320	360
	HG_25C	300	390	440
	HG_30C	370	480	550
	HG_35C	410	530	610
	HG_45C	510	660	750
	HG_55C	620	800	910
	HG_65C	760	980	1120
Super heavy load	HG_20H	310	400	460
	HG_25H	390	510	580
	HG_30H	480	620	710
	HG_35H	530	690	790
	HG_45H	650	850	970
	HG_55H	790	1030	1180
	HG_65H	1030	1330	1520

Unit: N/ μm

1.2.14 Dimensions of the HG block

1.2.14.1 HGH-CA / HGH-HA

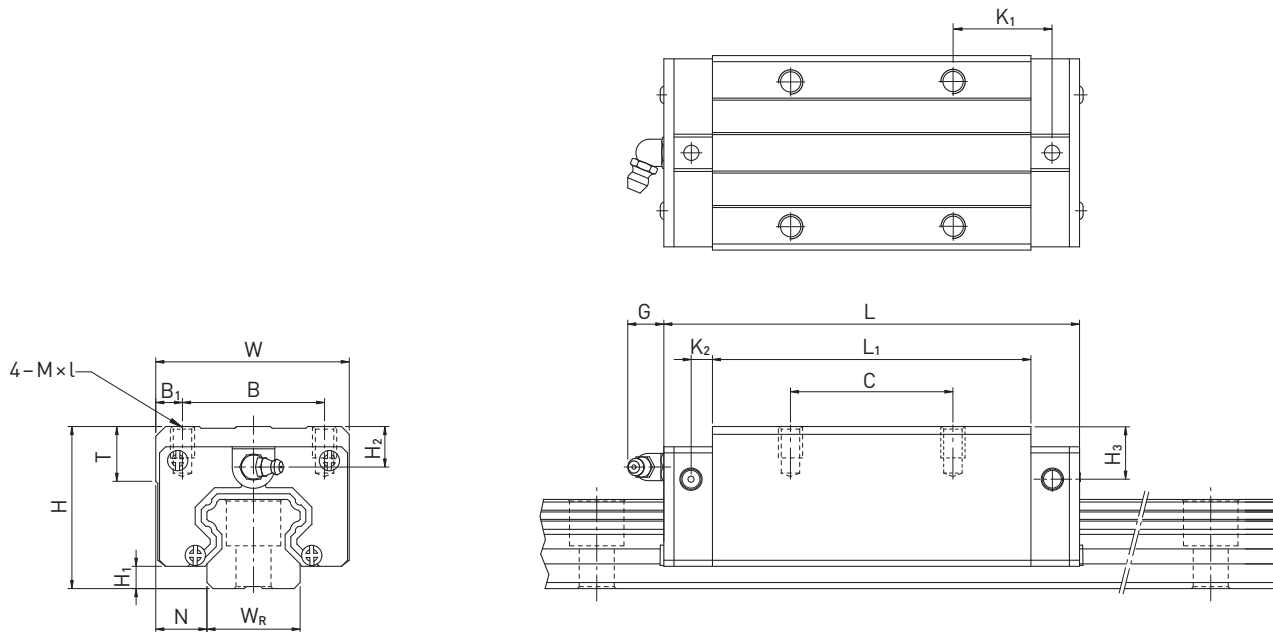

Table 1.14 Dimensions of the block

Series Size	Installation dim. [mm]			Dimensions of the block [mm]													Load Ratings [N]		Mass [kg]
	H	H ₁	N	W	B	B ₁	C	L ₁	L	K ₁	K ₂	G	M × l	T	H ₂	H ₃	C _{dyn}	C ₀	
HGH15CA	28	4,3	9,5	34	26,0	4,0	26	39,4	61,4	10,00	4,85	5,3	M4 × 5	6,0	7,95	7,7	11380	16970	0,18
HGH20CA	30	4,6	12,0	44	32,0	6,0	36	50,5	77,5	12,25	6,00	12,0	M5 × 6	8,0	6,00	6,0	17750	27760	0,30
HGH20HA							50	65,2	92,2	12,60							21180	35900	0,39
HGH25CA	40	5,5	12,5	48	35,0	6,5	35	58,0	84,0	16,80	6,00	12,0	M6 × 8	8,0	10,00	9,0	26480	36490	0,51
HGH25HA							50	78,6	104,6	19,60							32750	49440	0,69
HGH30CA	45	6,0	16,0	60	40,0	10,0	40	70,0	97,4	20,25	6,00	12,0	M8 × 10	8,5	9,50	13,8	38740	52190	0,88
HGH30HA							60	93,0	120,4	21,75							47270	69160	1,16
HGH35CA	55	7,5	18,0	70	50,0	10,0	50	80,0	112,4	20,60	7,00	12,0	M8 × 12	10,2	16,00	19,6	49520	69160	1,45
HGH35HA							72	105,8	138,2	22,50							60210	91630	1,92
HGH45CA	70	9,5	20,5	86	60,0	13,0	60	97,0	139,4	23,00	10,00	12,9	M10 × 17	16,0	18,50	30,5	77570	102710	2,73
HGH45HA							80	128,8	171,2	28,90							94540	136460	3,61
HGH55CA	80	13,0	23,5	100	75,0	12,5	75	117,7	166,7	27,35	11,00	12,9	M12 × 18	17,5	22,00	29,0	114440	148330	4,17
HGH55HA							95	155,8	204,8	36,40							139350	196200	5,49
HGH65CA	90	15,0	31,5	126	76,0	25,0	70	144,2	200,2	43,10	14,00	12,9	M16 × 20	25,0	15,00	15,0	163630	215330	7,00
HGH65HA							120	203,6	259,6	47,80							208360	303130	9,82

Dimensions of the rail see page 20, standard- and optional lubrication adapters see page 84.

Linear Guideways

HG series

1.2.14.2 HGL-CA / HGL-HA

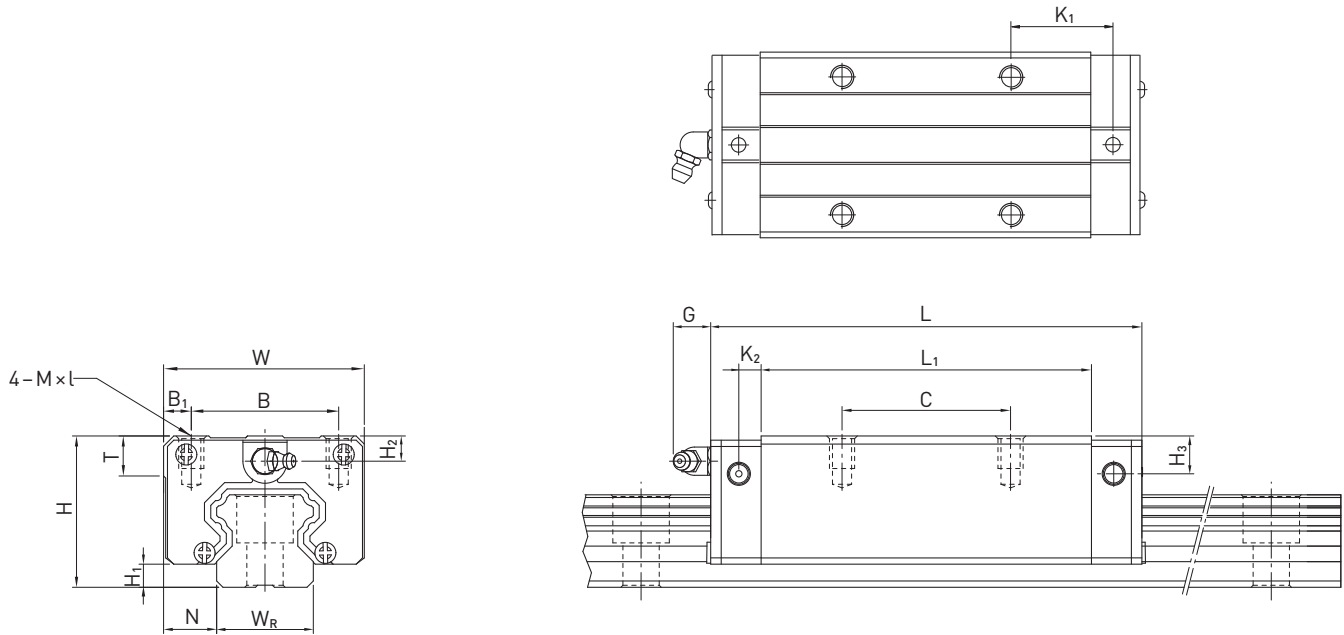

Table 1.15 Dimensions of the block

Series Size	Installation dim. [mm]			Dimensions of the block [mm]													Load Ratings [N]		Mass [kg]
	H	H ₁	N	W	B	B ₁	C	L ₁	L	K ₁	K ₂	G	M × l	T	H ₂	H ₃	C _{dyn}	C ₀	
HGL15CA	24	4,3	9,5	34	26,0	4,0	26	39,4	61,4	10,00	4,85	5,3	M4 × 4	6,0	3,95	3,7	11380	16970	0,14
HGL25CA	36	5,5	12,5	48	35,0	6,5	35	58,0	84,0	15,70	6,00	12,0	M6 × 6	8,0	6,00	5,0	26480	36490	0,42
HGL25HA							50	78,6	104,6	18,50							32750	49440	0,57
HGL30CA	42	6,0	16,0	60	40,0	10,0	40	70,0	97,4	20,25	6,00	12,0	M8 × 10	8,5	6,50	10,8	38740	52190	0,78
HGL30HA							60	93,0	120,4	21,75							47270	69160	1,03
HGL35CA	48	7,5	18,0	70	50,0	10,0	50	80,0	112,4	20,60	7,00	12,0	M8 × 12	10,2	9,00	12,6	49520	69160	1,14
HGL35HA							72	105,8	138,2	22,50							60210	91630	1,52
HGL45CA	60	9,5	20,5	86	60,0	13,0	60	97,0	139,4	23,00	10,00	12,9	M10 × 17	16,0	8,50	20,5	77570	102710	2,08
HGL45HA							80	128,8	171,2	28,90							94540	136460	2,75
HGL55CA	70	13,0	23,5	100	75,0	12,5	75	117,7	166,7	27,35	11,00	12,9	M12 × 18	17,5	12,00	19,0	114440	148330	3,25
HGL55HA							95	155,8	204,8	36,40							139350	196200	4,27

Dimensions of the rail see page 20, standard- and optional lubrication adapters see page 84.

1.2.14.3 HGW-CC / HGW-HC

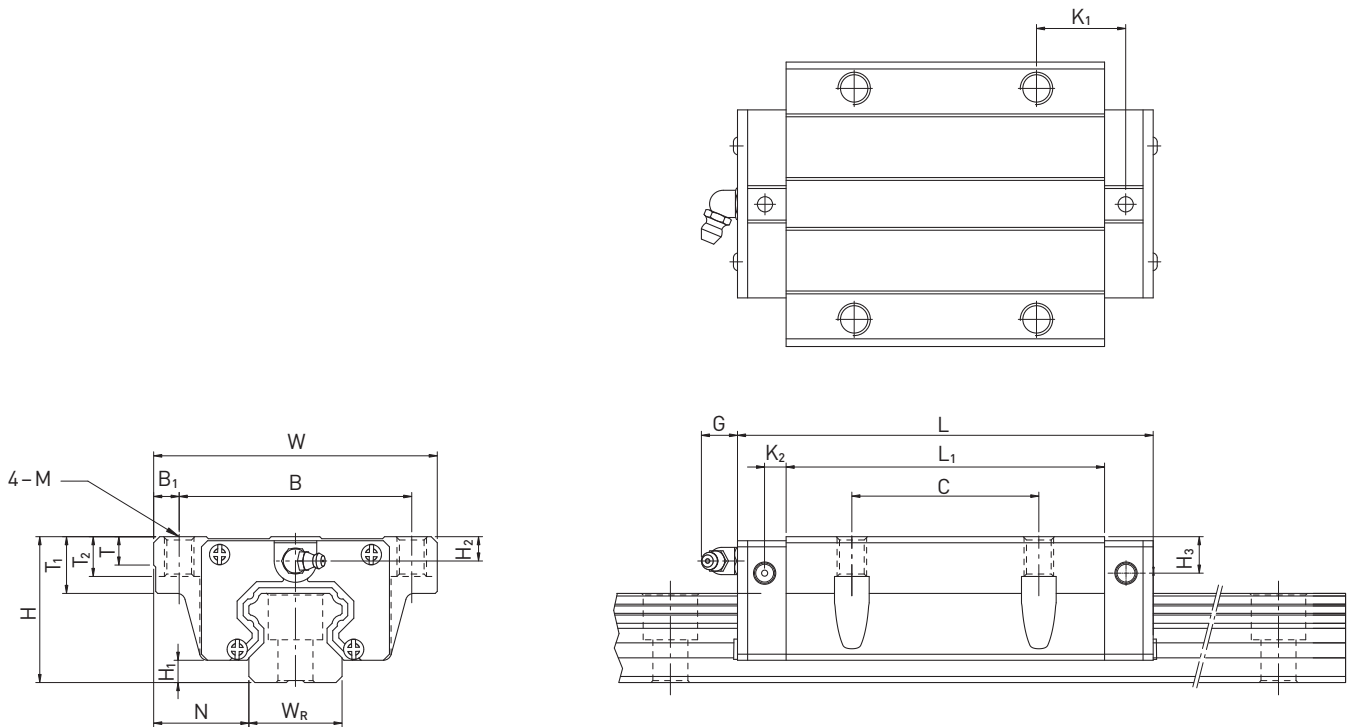

Table 1.16 Dimensions of the block

Series Size	Installation dim. [mm]			Dimensions of the block [mm]															Load Ratings [N]		Mass [kg]
	H	H ₁	N	W	B	B ₁	C	L ₁	L	K ₁	K ₂	M	G	T	T ₁	T ₂	H ₂	H ₃	C _{dyn}	C ₀	
HGW15CC	24	4,3	16,0	47	38,0	4,5	30	39,4	61,4	8,00	4,85	M5	5,3	6,0	8,9	7,0	3,95	3,7	11380	16970	0,17
HGW20CC	30	4,6	21,5	63	53,0	5,0	40	50,5	77,5	10,25	6,00	M6	12,0	8,0	10,0	9,5	6,00	6,0	17750	27760	0,40
HGW20HC								65,2	92,2	17,60											
HGW25CC	36	5,5	23,5	70	57,0	6,5	45	58,0	84,0	10,70	6,00	M8	12,0	8,0	14,0	10,0	6,00	5,0	26480	36490	0,59
HGW25HC								78,6	104,6	21,00											
HGW30CC	42	6,0	31,0	90	72,0	9,0	52	70,0	97,4	14,25	6,00	M10	12,0	8,5	16,0	10,0	6,50	10,8	38740	52190	1,09
HGW30HC								93,0	120,4	25,75											
HGW35CC	48	7,5	33,0	100	82,0	9,0	62	80,0	112,4	14,60	7,00	M10	12,0	10,1	18,0	13,0	9,00	12,6	49520	69160	1,56
HGW35HC								105,8	138,2	27,50											
HGW45CC	60	9,5	37,5	120	100,0	10,0	80	97,0	139,4	13,00	10,00	M12	12,9	15,1	22,0	15,0	8,50	20,5	77570	102710	2,79
HGW45HC								128,8	171,2	28,90											
HGW55CC	70	13,0	43,5	140	116,0	12,0	95	117,7	166,7	17,35	11,00	M14	12,9	17,5	26,5	17,0	12,00	19,0	114440	148330	4,52
HGW55HC								155,8	204,8	36,40											
HGW65CC	90	15,0	53,5	170	142,0	14,0	110	144,2	200,2	23,10	14,00	M16	12,9	25,0	37,5	23,0	15,00	15,0	163630	215330	9,17
HGW65HC								203,6	259,6	52,80											

Dimensions of the rail see page 20, standard- and optional lubrication adapters see page 84.

Linear Guideways

HG series

1.2.15 Dimensions of the HG rail

1.2.15.1 Dimensions HGR_R

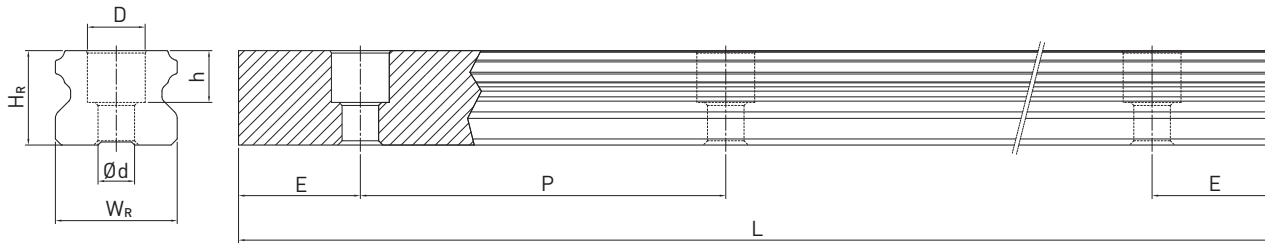

Table 1.17 Dimensions of the rail HGR_R

Series Size	Screws for rail [mm]	Dimensions of the rail [mm]						Max. length [mm]	Max. length $E_1 = E_2$	$E_{1/2}$ min [mm]	$E_{1/2}$ max [mm]	Mass [kg/m]
		W_R	H_R	D	h	d	P					
HGR15R	M4 × 16	15	15,0	7,5	5,3	4,5	60,0	4000	3900	6	54	1,45
HGR20R	M5 × 16	20	17,5	9,5	8,5	6,0	60,0	4000	3900	7	53	2,21
HGR25R	M6 × 20	23	22,0	11,0	9,0	7,0	60,0	4000	3900	8	52	3,21
HGR30R	M8 × 25	28	26,0	14,0	12,0	9,0	80,0	4000	3920	9	71	4,47
HGR35R	M8 × 25	34	29,0	14,0	12,0	9,0	80,0	4000	3920	9	71	6,30
HGR45R	M12 × 35	45	38,0	20,0	17,0	14,0	105,0	4000	3885	12	93	10,41
HGR55R	M14 × 45	53	44,0	23,0	20,0	16,0	120,0	4000	3840	14	106	15,08
HGR65R	M16 × 50	63	53,0	26,0	22,0	18,0	150,0	4000	3750	15	135	21,18

1.2.15.2 Dimensions HGR_T (rail mounting from below)

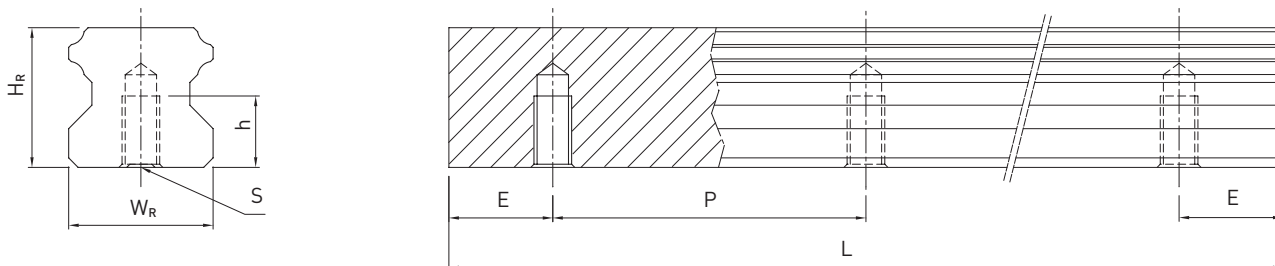

Table 1.18 Dimensions of the rail HGR_T

Series Size	Dimensions of the rail [mm]					Max. length [mm]	Max. length $E_1 = E_2$	$E_{1/2}$ min [mm]	$E_{1/2}$ max [mm]	Mass [kg/m]
	W_R	H_R	S	h	P					
HGR15T	15	15,0	M5	8,0	60,0	4000	3900	6	54	1,48
HGR20T	20	17,5	M6	10,0	60,0	4000	3900	7	53	2,29
HGR25T	23	22,0	M6	12,0	60,0	4000	3900	8	52	3,35
HGR30T	28	26,0	M8	15,0	80,0	4000	3920	9	71	4,67
HGR35T	34	29,0	M8	17,0	80,0	4000	3920	9	71	6,51
HGR45T	45	38,0	M12	24,0	105,0	4000	3885	12	93	10,87
HGR55T	53	44,0	M14	24,0	120,0	4000	3840	14	106	15,67
HGR65T	63	53,0	M20	30,0	150,0	4000	3750	15	135	21,73

Note:

1. The tolerance for E is +0,5 to -1 mm for standard, for joint connections 0 to -0.3 mm
2. If no information is provided on the $E_{1/2}$ dimensions, the maximum number of fixing holes is determined taking into account $E_{1/2}$ min
3. The rails are shortened to the desired length. If no information on the $E_{1/2}$ dimensions is provided, then the rails are manufactured symmetrically.

1.2.15.3 Calculation of the length of rails

HIWIN offers customer-specific lengths. To ensure that the ends of the rails for non-standard lengths are stable, value E must not exceed half the distance between the fixing holes (P). In addition, value $E_{1/2}$ must not be less than $E_{1/2min}$ and must not exceed $E_{1/2max}$ to prevent breakage of the fixing hole.

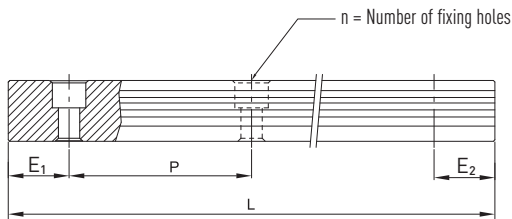

$$L = (n-1) \cdot P + E_1 + E_2$$

L: Total rail length [mm]
 n: Number of fixing holes
 P: Distance between two fixing holes [mm]
 $E_{1/2}$: Distance from the center of the last fixing hole to the end of the rail [mm]

1.2.15.4 Tightening torques for fixing screws

Insufficient tightening of the fixing screws will highly detract from the accuracy of the linear guideway; the following tightening torques are recommended for the respective screw sizes.

Table 1.20 Tightening torque for fixing screws to ISO 4762-12.9

Series/Size	Screw size	Torque [Nm]	Series/Size	Screw size	Torque [Nm]
HG_15	M4 × 16	4	HG_35	M8 × 25	30
HG_20	M5 × 16	9	HG_45	M12 × 35	120
HG_25	M6 × 20	13	HG_55	M14 × 45	160
HG_30	M8 × 25	30	HG_65	M16 × 50	200

1.2.15.5 Cover cap for rail fixing holes

The cover caps are used to keep the fixing holes free from chips and dirt. The standard plastic bolt caps are enclosed to each rail. Optional caps have to be ordered extra.

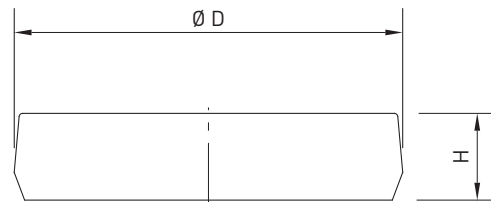

Table 1.21 Cover cap for rail fixing holes

Rail	Screw	Article number			Ø D [mm]	Height H [mm]
		Plastic	Brass	Steel		
HGR15R	M4	C4	C4-M	—	7,5	1,1
HGR20R	M5	C5	C5-M	C5-ST	9,5	2,2
HGR25R	M6	C6	C6-M	C6-ST	11,0	2,5
HGR30R	M8	C8	C8-M	C8-ST	14,0	3,3
HGR35R	M8	C8	C8-M	C8-ST	14,0	3,3
HGR45R	M12	C12	C12-M	C12-ST	20,0	4,6
HGR55R	M14	C14	C14-M	C14-ST	23,0	5,5
HGR65R	M16	C16	C16-M	C16-ST	26,0	5,5

Linear Guideways

EG series

1.3 Linear Guideway Series EG

1.3.1 Special characteristics of the linear guideway series EG

The design of the EG series offers a low profile, high load capacity, and high rigidity. It also features an equal load rating in all four directions and self-aligning capability to absorb installation-error, allowing for higher accuracies. Additionally, the lower assembly height and the shorter length makes the EG series more suitable for high-speed automation machines and applications where space is limited. The retainer is designed to hold the balls in the block even when it is removed from the rail.

1.3.2 Construction of the EG series

- 4-row recirculating ball bearing guide
- 45° contact angle of the ball tracks
- The ball retainers prevent the balls from falling out when the carriage is removed
- Different sealing variants, depending on application area
- Six connection options for grease nipples or grease adapters

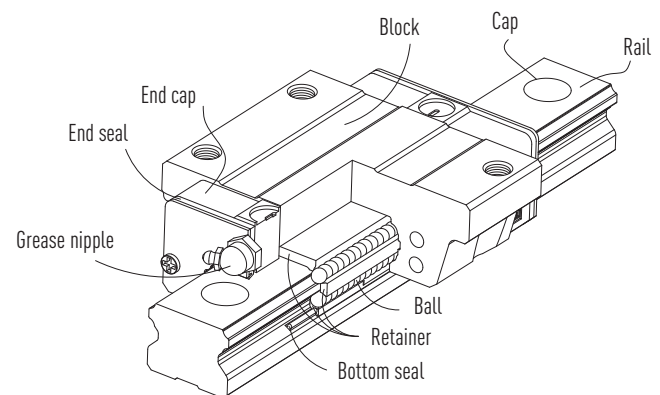

Fig. Construction of the EG series

1.3.3 Advantages

- Free of play
- Replaceable
- High precision
- High load ratings and rigidity in all directions
- Low friction losses even with preload by optimized ball tracks and 2-point contact

1.3.4 Article numbers for the EG series

EG linear guideways are available as either interchangeable or non-interchangeable versions. The dimensions of both models are identical. The interchangeable models are more user friendly, as the block and rail can be replaced freely. However, accuracy is lower than that of the non-interchangeable models. Due to the strict control of dimensional accuracy, the interchangeable models are a good choice for customers not using pairs of rails on a stage. The article numbers include the dimensions, model, accuracy class and preload class etc.

1.3.4.1 Non-interchangeable models (customized models)

○ Item number of the fully installed linear guideway

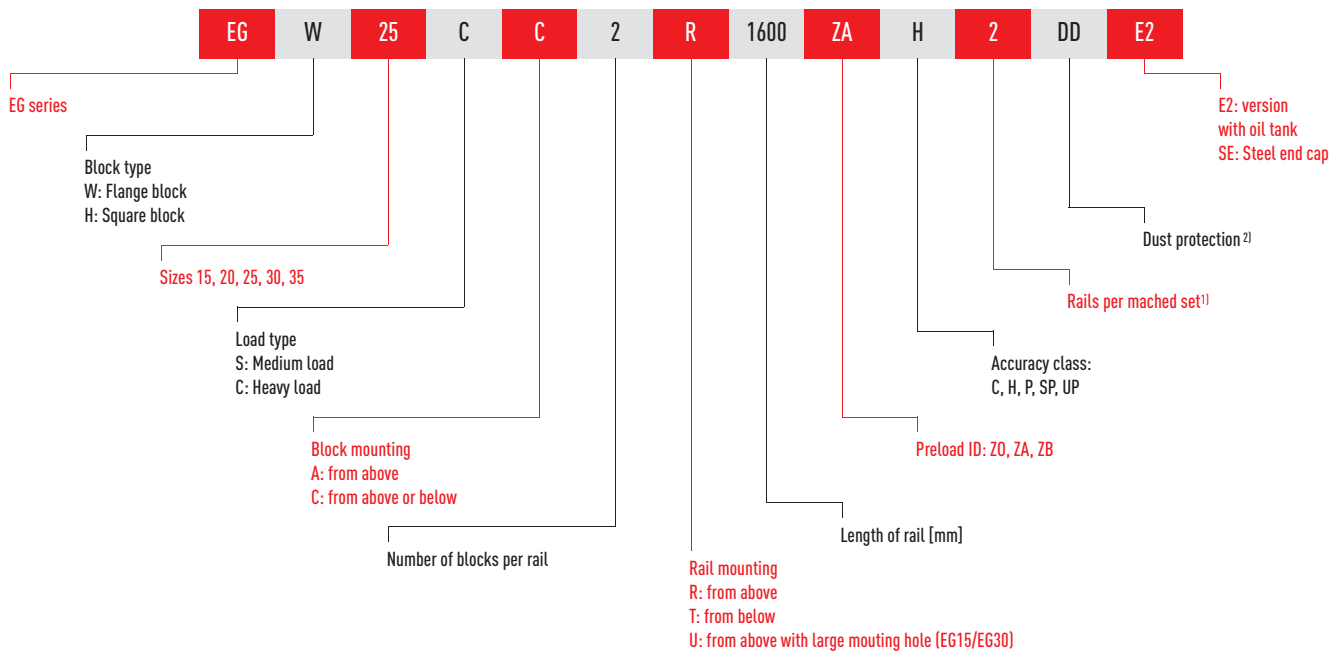

1.3.4.2 Interchangeable models

○ Article number of the EG block

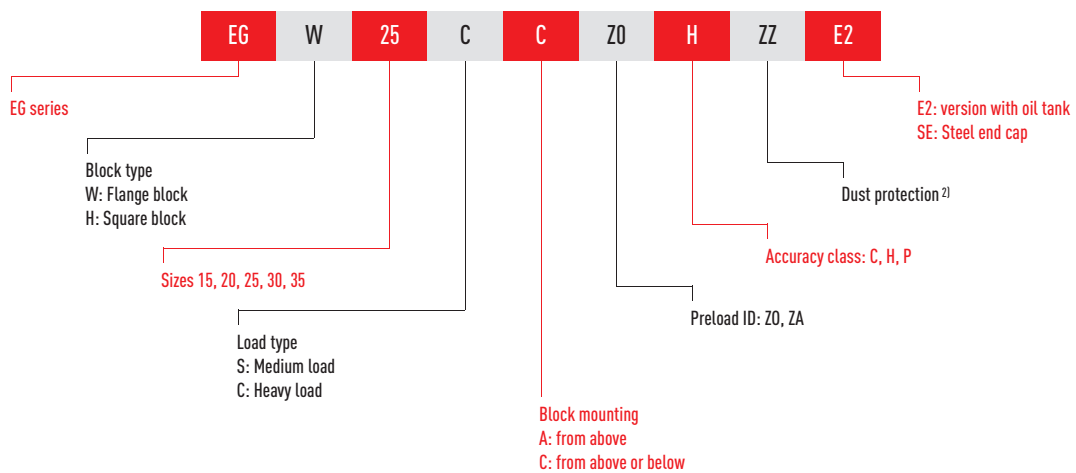

○ Article number of the EG rail

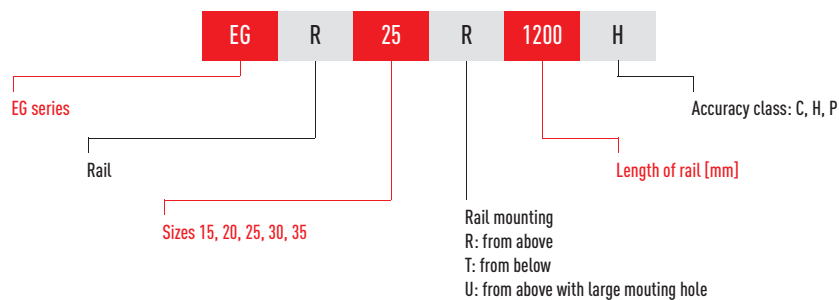

Note:

1) The number 2 is also a quantity statement, i.e. a piece of the above described article consists of a pair of rails. No declaration means singel rail.

2) No information is provided for the standard version for dust protection (end seal and bottom seal)

ZZ: End seal, bottom seal and scraper

KK: Double seals, bottom seal and scraper

DD: Double seals and bottom seal

Linear Guideways

EG series

1.3.5 Block types

HIWIN offers square blocks and flange blocks for its linear guideways. The low assembly height and larger installation surface makes flange blocks more suitable for heavy loads.

Table 1.22 Block types

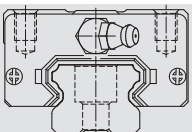
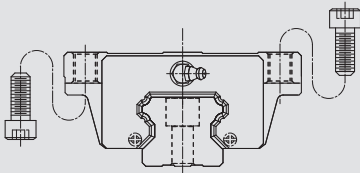
Type	Series Size	Construction	Height [mm]	Rail length [mm]	Typical application
Block design	EGH-SA EGH-CA		24 – 48	100 – 4.000	<ul style="list-style-type: none"> ○ Machining centers ○ NC lathes ○ Grinders ○ Precision milling ○ High-performance cutting machinery ○ Automation technology ○ Transportation technology ○ Measuring technology ○ Machines and devices requiring a high level of positioning accuracy
Flange	EGW-SC EGW-CC				

1.3.6 Preload

1.3.6.1 Definition

A preload can be applied to any rails version. For this purpose, oversized balls are used. Normally a linear guideway has a negative clearance between the path and the ball bearings, to increase rigidity and precision. The curve shows that rigidity doubles with a high preload. A preload not larger than ZA would be recommended for all model sizes under EG20 to avoid a reduction of service life.

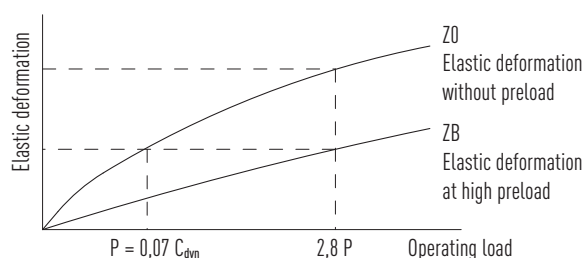

1.3.6.2 Preload ID

Table 1.23 Preload ID

ID	Preload		Application	Example applications
Z0	Light preload	0 – 0,02 C_{dyn}	Constant load direction, low impacts, low accuracy required	Transportation technology, automatic packaging machinery, X-Y stages for industrial machinery, automated welding machinery
ZA	Medium preload	0,03 – 0,05 C_{dyn}	High precision required	Machining centers, Z stages for industrial machinery, erosion machinery, NC lathes, precision X-Y benches, measuring technology
ZB	High preload	0,06 – 0,08 C_{dyn}	High rigidity required, with vibrations and impacts	Machining centers, grinding machinery, NC lathes, horizontal and vertical milling machinery, Z stage of machine tools, high-performance cutting machinery

Note:

Preload classes for interchangeable versions Z0 and ZA. For non-interchangeable versions: Z0, ZA, ZB.

1.3.7 Accuracy classes

The EG series is divided into five classes according to respective accuracy – normal (C), high (H), precision class (P), super precision class (SP) and ultra precision class (UP). The requirements of the machinery in which the linear guideway is used, determine the selection.

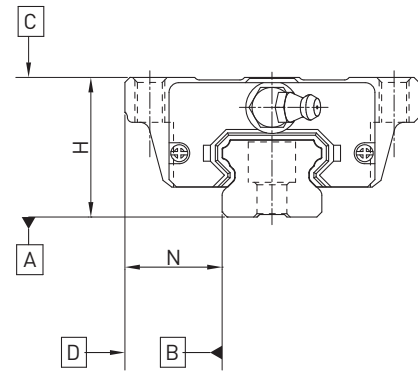

1.3.7.1 Accuracy classes of non-interchangeable types

Parallelism of block surface C with surface A, see table 1.26

Parallelism of block surface D with surface B, see table 1.26

Table 1.24 Tolerances depending on the accuracy class

Series/Size	Accuracy class	Height tolerance of H ¹⁾	Width tolerance of N ¹⁾	Height variance of H ²⁾	Width variance of N ²⁾
EG_15, 20	Normal (C)	± 0,1	± 0,1	0,02	0,02
	High (H)	± 0,03	± 0,03	0,01	0,01
	Precision (P)	0 - 0,03	0 - 0,03	0,006	0,006
	Super precision (SP)	0 - 0,015	0 - 0,015	0,004	0,004
	Ultra precision (UP)	0 - 0,008	0 - 0,008	0,003	0,003
EG_25, 30, 35	Normal (C)	± 0,1	± 0,1	0,02	0,03
	High (H)	± 0,04	± 0,04	0,015	0,015
	Precision (P)	0 - 0,04	0 - 0,04	0,007	0,007
	Super precision (SP)	0 - 0,02	0 - 0,02	0,005	0,005
	Ultra precision (UP)	0 - 0,01	0 - 0,01	0,003	0,003

Unit: mm

¹⁾ Tolerance data that applies to any block on any rail

²⁾ Permissible absolute dimensional deviation between several blocks, distributed over one individual rail or located on a pair of rails

1.3.7.2 Accuracy classes of interchangeable types

Parallelism of block surface C with surface A, see table 1.26

Parallelism of block surface D with surface B, see table 1.26

Table 1.25 Tolerances depending on the accuracy class

Series/Size	Accuracy class	Height tolerance of H ¹⁾	Width tolerance of N ¹⁾	Height variance of H ²⁾	Width variance of N ²⁾
EG_15, 20	Normal (C)	± 0,1	± 0,1	0,02	0,02
	High (H)	± 0,03	± 0,03	0,01	0,01
	Precision (P)	± 0,015	± 0,015	0,006	0,006
EG_25, 30, 35	Normal (C)	± 0,1	± 0,1	0,02	0,03
	High (H)	± 0,04	± 0,04	0,015	0,015
	Precision (P)	± 0,02	± 0,02	0,007	0,007

Unit: mm

¹⁾ Tolerance data that applies to any block on any rail

²⁾ Permissible absolute dimensional deviation between several blocks, distributed over one individual rail or located on a pair of rails

Linear Guideways

EG series

Table 1.26 Tolerance parallelism between block and rail

Rail length [mm]	Accuracy class					
	C	H	P	SP	UP	
– 100	12	7	3	2	2	
100 – 200	14	9	4	2	2	
200 – 300	15	10	5	3	2	
300 – 500	17	12	6	3	2	
500 – 700	20	13	7	4	2	
700 – 900	22	15	8	5	3	
900 – 1100	24	16	9	6	3	
1100 – 1500	26	18	11	7	4	
1500 – 1900	28	20	13	8	4	
1900 – 2500	31	22	15	10	5	
2500 – 3100	33	25	18	11	6	
3100 – 3600	36	27	20	14	7	
3600 – 4000	37	28	21	15	7	

Unit: μm

1.3.8 Dust protection

A variety of sealing systems are available for the HIWIN sliding carriage. You will find an overview of these on page 87. In the following table, the overall lengths of the sliding carriages with different sealing systems are listed. The corresponding sealing systems are available for these design sizes.

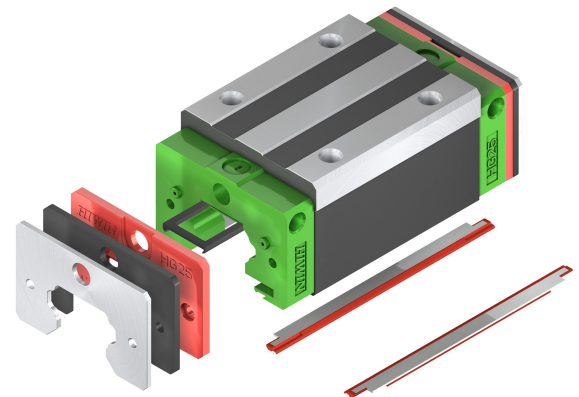
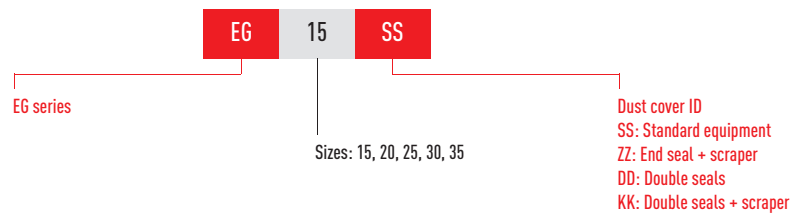

Table 1.27 The overall length of the sliding carriage with different sealing systems

Series Size	Gesamtlänge L					
	SS	DD	ZZ	KK	SW	ZWX
HG_15C	40,1	44,1	41,7	45,7	–	–
HG_20C	56,8	60,8	58,4	62,4	–	–
HG_20H	50,0	54,0	51,6	55,6	–	–
HG_25C	69,1	73,1	70,7	74,7	–	–
HG_25H	59,1	63,1	61,1	65,1	–	–
HG_30C	82,6	86,6	84,6	88,6	–	–
HG_30H	69,5	73,5	71,5	75,5	–	–
HG_35C	98,1	102,1	100,1	104,1	–	–
HG_35H	75,0	79,0	78,0	82,0	–	–
HG_45C	108,0	112,0	111,0	115,0	–	–

1.3.8.1 Designation of the seal sets

The seal sets are always shipped complete with the installation materials and include the supplemental parts for the standard seal.



1.3.9 Friction

The table shows the maximum frictional resistance of the single endseal. Depending on the seal arrangement (SS, ZZ, DD, KK), the value has to be multiplied accordingly. The specified values apply to blocks on uncoated rails. Higher frictional forces occur on coated rails.

Table 1.29 Frictional resistance of the single-lip seals

Series/Size	Resistance [N]	Series/Size	Resistance [N]
EG_15	1,0	EG_30	1,5
EG_20	1,0	EG_35	2,0
EG_25	1,0		

Linear Guideways

EG series

1.3.10 The accuracy tolerance of rail-mounting surface

Because of the circular-arc contact design, the EG linear guideway can compensate for some surface-error on installation and still maintain smooth linear motion. As long as the accuracy requirements for the mounting surface are followed, high accuracy and rigidity of linear motion of the guideway can be obtained without any difficulty. In order to satisfy the needs of fast installation and smooth movement, HIWIN offers the normal clearance type of preload to customers of its high absorption ability of the deviation in mounting surface accuracy.

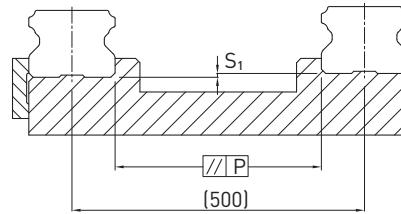

Parallelism tolerance of reference surface (P)

Table 1.30 Maximum tolerances for the parallel alignment (P)

Series/Size	Load class		
	Z0	ZA	ZB
EG_15	25	18	—
EG_20	25	20	18
EG_25	30	22	20
EG_30	40	30	27
EG_35	50	35	30

Unit: μm

Table 1.31 Maximum tolerance of reference surface height (S_1)

Series/Size	Load class		
	Z0	ZA	ZB
EG_15	130	85	—
EG_20	130	85	50
EG_25	130	85	70
EG_30	170	110	90
EG_35	210	150	120

Unit: μm

1.3.11 Shoulder heights and fillets

Improper shoulder heights and fillets of mounting surfaces will cause a deviation in accuracy and the interference with the chamfered part of the rail or block. As long as the recommended shoulder heights and fillets are followed, installation inaccuracies should be eliminated.

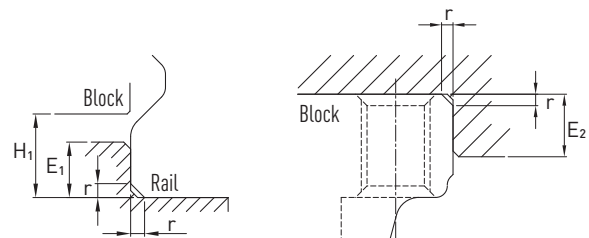

Table 1.32 Shoulder heights and fillets

Series/Size	Max. radius of fillets r	Shoulder height of the rail E_1	Shoulder height of the block E_2	Clearance under block H_1
EG_15	0,5	2,7	5,0	4,5
EG_20	0,5	5,0	7,0	6,0
EG_25	1,0	5,0	7,5	7,0
EG_30	1,0	7,0	7,0	10,0
EG_35	1,0	7,5	9,5	11,0

Unit: mm

1.3.12 Load ratings and torques

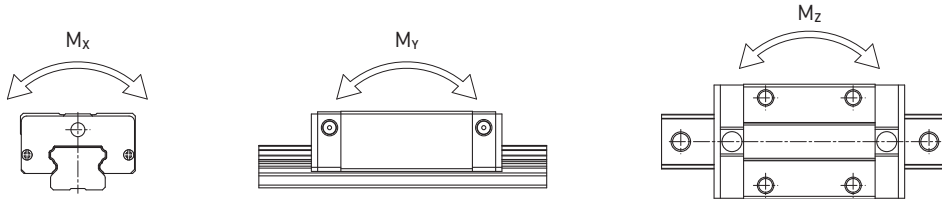

Table 1.33 Load ratings and torques series EG

Series/Size	Dynamic load C_{dyn} [N]*	Static load C_0 [N]	Dynamic moment [Nm]			Static moment [Nm]		
			M_x	M_y	M_z	M_{0x}	M_{0y}	M_{0z}
EG_15S	5350	9400	45	22	22	80	40	40
EG_15C	7830	16190	62	48	48	130	100	100
EG_20S	7230	12740	73	34	34	130	60	60
EG_20C	10310	21130	107	78	78	220	160	160
EG_25S	11400	19500	134	70	70	230	120	120
EG_25C	16270	32400	190	160	160	380	320	320
EG_30S	16420	28100	233	122	122	400	210	210
EG_30C	23700	47460	339	274	274	680	550	550
EG_35S	22660	37380	339	187	187	560	310	310
EG_35C	33350	64840	504	354	354	980	690	690

* Dynamic load rating for 50,000 m travel path

1.3.13 Rigidity

Rigidity is dependent on the preload. Using formula 1.1, it is possible to determine the deformation in relation to the rigidity.

$$\delta = \frac{P}{k}$$

δ : deformation [μm]
 P : Operating load [N]
 k : Rigidity value [N/ μm]

Formula 1.1

Table 1.34 Radial rigidity series EG

Load class	Series Size	Preload		
		Z0	ZA	ZB
Medium load	EG_15S	105	126	141
	EG_20S	126	151	168
	EG_25S	156	187	209
	EG_30S	184	221	246
	EG_35S	221	265	295
Heavy load	EG_15C	172	206	230
	EG_20C	199	238	266
	EG_25C	246	296	329
	EG_30C	295	354	395
	EG_35C	354	425	474

Unit: N/ μm

Linear Guideways

EG series

1.3.14 Dimensions of the EG block

1.3.14.1 EGH-SA / EGH-CA

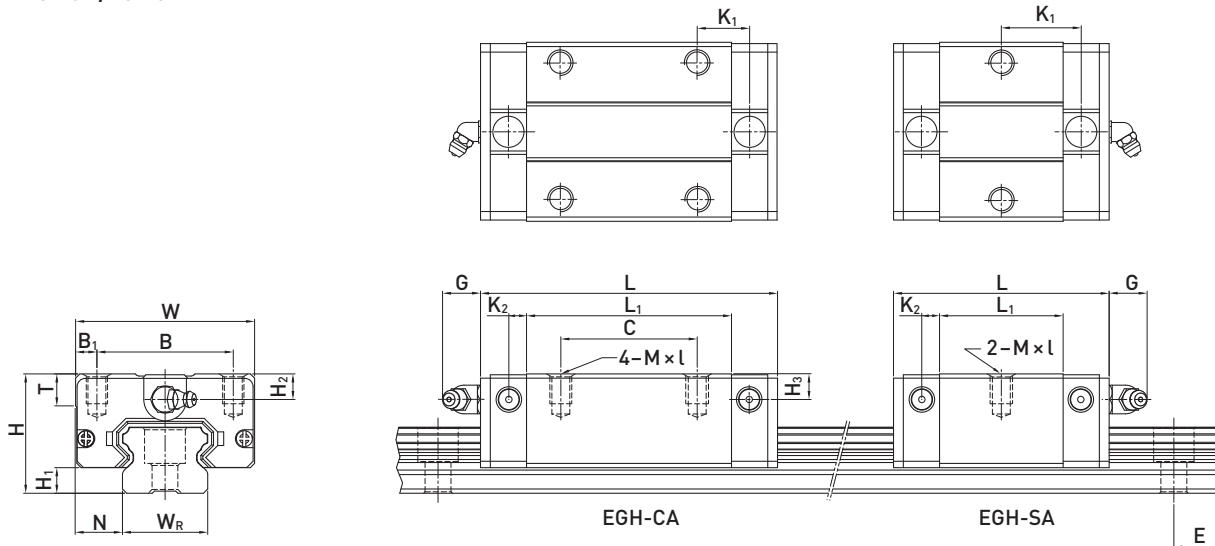

Table 1.35 Dimensions of the block

Series Size	Installation dim. [mm]			Dimensions of the block [mm]													Load Ratings [N]		Mass [kg]
	H	H ₁	N	W	B	B ₁	C	L ₁	L	K ₁	K ₂	G	M × l	T	H ₂	H ₃	C _{dyn}	C ₀	
EGH15SA	24	4,5	9,5	34	26,0	4,0	0	23,1	40,1	14,80	3,50	5,7	M4 × 6	6,0	5,50	6,0	5350	9400	0,09
EGH15CA							26	39,8	56,8	10,15							7830	16190	0,15
EGH20SA	28	6,0	11,0	42	32,0	5,0	0	29,0	50,0	18,75	4,15	12,0	M5 × 7	7,5	6,00	6,0	7230	12740	0,15
EGH20CA							32	48,1	69,1	12,30							10310	21130	0,24
EGH25SA	33	7,0	12,5	48	35,0	6,5	0	35,5	59,1	21,90	4,55	12,0	M6 × 9	8,0	8,00	8,0	11400	19500	0,25
EGH25CA							35	59,0	82,6	16,15							16270	32400	0,41
EGH30SA	42	10,0	16,0	60	40,0	10,0	0	41,5	69,5	26,75	6,00	12,0	M8 × 12	9,0	8,00	9,0	16420	28100	0,45
EGH30CA							40	70,1	98,1	21,05							23700	47460	0,76
EGH35SA	48	11,0	18,0	70	50,0	10,0	0	45,0	75,0	28,50	7,00	12,0	M8 × 12	10,0	8,50	8,5	22660	37380	0,74
EGH35CA							50	78,0	108,0	20,00							33350	64840	1,10

Dimensions of the rail see page 32, standard- and optional lubrication adapters see page 84.

1.3.14.2 EGW-SC / EGW-CC

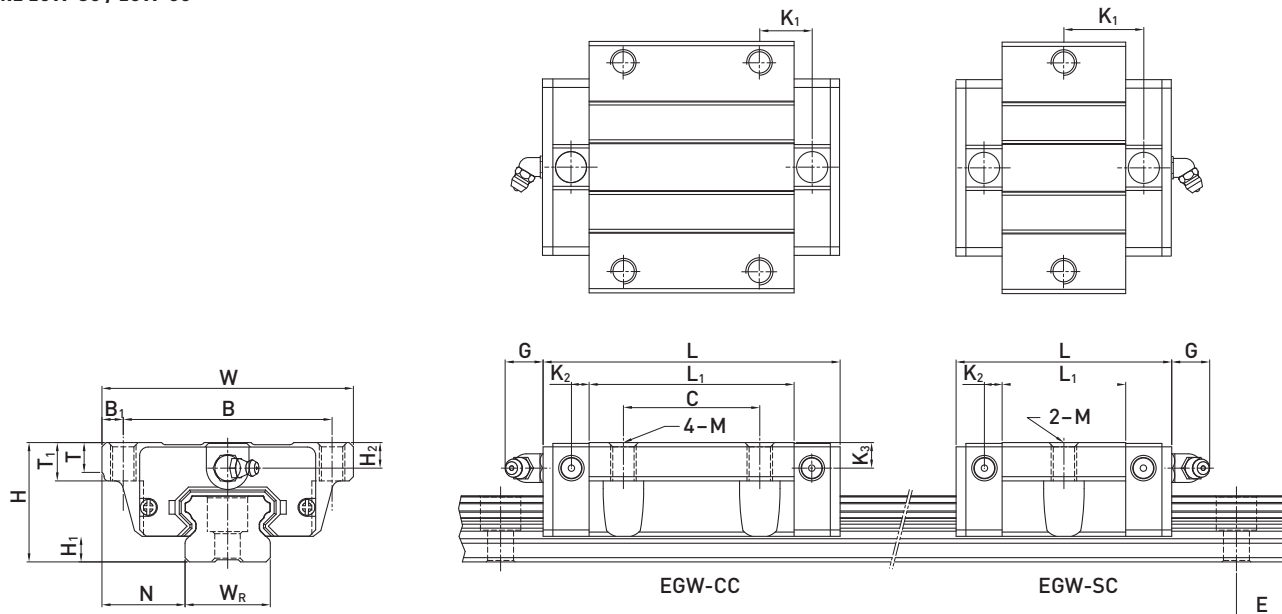

Table 1.36 Dimensions of the block

Series Size	Installation dim. [mm]			Dimensions of the block [mm]															Load Ratings [N]		Mass [kg]
	H	H ₁	N	W	B	B ₁	C	L ₁	L	K ₁	K ₂	G	M	T	T ₁	H ₂	H ₃	C _{dyn}	C ₀		
EGW15SC	24	4,5	18,5	52	41,0	5,5	0	23,1	40,1	14,80	3,50	5,7	M5	5,0	7,0	5,50	6,0	5350	9400	0,12	
EGW15CC							26	39,8	56,8	10,15								7830	16190	0,21	
EGW20SC	28	6,0	19,5	59	49,0	5,0	0	29,0	50,0	18,75	4,15	12,0	M6	7,0	9,0	6,00	6,0	7230	12740	0,19	
EGW20CC							32	48,1	69,1	12,30								10310	21130	0,32	
EGW25SC	33	7,0	25,0	73	60,0	6,5	0	35,5	59,1	21,90	4,55	12,0	M8	7,5	10,0	8,00	8,0	11400	19500	0,35	
EGW25CC							35	59,0	82,6	16,15								16270	32400	0,59	
EGW30SC	42	10,0	31,0	90	72,0	9,0	0	41,5	69,5	26,75	6,00	12,0	M10	7,0	10,0	8,00	9,0	16420	28100	0,62	
EGW30CC							40	70,1	98,1	21,05								23700	47460	1,04	
EGW35SC	48	11,0	33,0	100	82,0	9,0	0	45,0	75,0	28,50	7,00	12,0	M10	10,0	13,0	8,50	8,5	22660	37380	0,91	
EGW35CC							50	78,0	108,0	20,00								33350	64840	1,40	

Dimensions of the rail see page 32, standard- and optional lubrication adapters see page 84.

Linear Guideways

EG series

1.3.15 Dimensions of the EG rail

1.3.15.1 Dimensions EGR_R

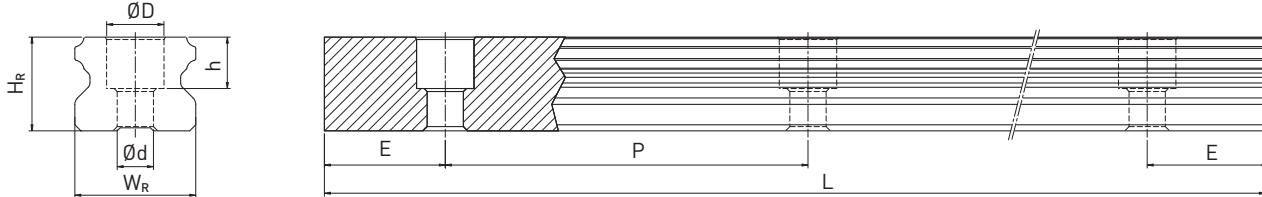

Table 1.37 Dimensions of the rail EGR_R

Series Size	Screws for rail [mm]	Dimensions of the rail [mm]						Max. length [mm]	Max. length $E_1 = E_2$	$E_{1/2}$ min [mm]	$E_{1/2}$ max [mm]	Mass [kg/m]
		W_R	H_R	D	h	d	P					
EGR15R	M3 × 16	15	12,5	6,0	4,5	3,5	60,0	4000	3900	6	54	1,25
EGR20R	M5 × 16	20	15,5	9,5	8,5	6,0	60,0	4000	3900	7	53	2,08
EGR25R	M6 × 20	23	18,0	11,0	9,0	7,0	60,0	4000	3900	8	52	2,67
EGR30R	M6 × 25	28	23,0	11,0	9,0	7,0	80,0	4000	3920	9	71	4,35
EGR35R	M8 × 25	34	27,5	14,0	12,0	9,0	80,0	4000	3920	9	71	6,14

1.3.15.2 Dimensions EGR_U (large mounting hole)

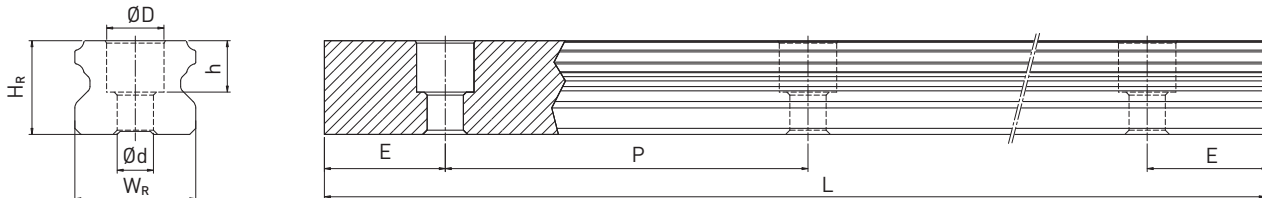

Table 1.38 Dimensions of the rail EGR_U

Series Size	Screws for rail [mm]	Dimensions of the rail [mm]						Max. length [mm]	Max. length $E_1 = E_2$	$E_{1/2}$ min [mm]	$E_{1/2}$ max [mm]	Mass [kg/m]
		W_R	H_R	D	h	d	P					
EGR15U	M4 × 16	15	12,5	7,5	5,3	4,5	60,0	4000	3900	6	54	1,23
EGR30U	M8 × 25	28	23,0	14,0	12,0	9,0	80,0	4000	3920	9	71	4,23

1.3.15.3 Dimensions EGR_T (mounting from below)

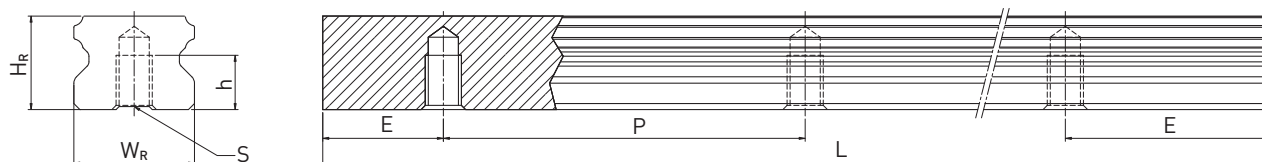

Table 1.39

Series Size	Dimensions of the rail [mm]					Max. length [mm]	Max. length $E_1 = E_2$	$E_{1/2}$ min [mm]	$E_{1/2}$ max [mm]	Mass [kg/m]
	W_R	H_R	S	h	P					
EGR15T	15	12,5	M5	7,0	60,0	4000	3900	6	54	1,26
EGR20T	20	15,5	M6	9,0	60,0	4000	3900	7	53	2,15
EGR25T	23	18,0	M6	10,0	60,0	4000	3900	8	52	2,79
EGR30T	28	23,0	M8	14,0	80,0	4000	3920	9	71	4,42
EGR35T	34	27,5	M8	17,0	80,0	4000	3920	9	71	6,34

Note:

1. The tolerance for E is +0,5 to -1 mm for standard, for joint connections 0 to -0,3 mm
2. If no information is provided on the $E_{1/2}$ dimensions, the maximum number of fixing holes is determined taking into account $E_{1/2}$ min
3. The rails are shortened to the desired length. If no information on the $E_{1/2}$ dimensions is provided, then the rails are manufactured symmetrically.

1.3.15.4 Calculation of the length of rails

HIWIN offers customer-specific lengths. To ensure that the ends of the rails for non-standard lengths are stable, value E must not exceed half the distance between the fixing holes (P). In addition, value $E_{1/2}$ must not be less than $E_{1/2 \text{ min}}$ and must not exceed $E_{1/2 \text{ max}}$ to prevent breakage of the fixing hole.

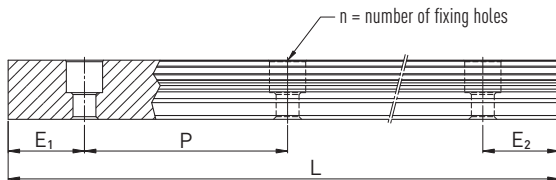

$$L = (n-1) \cdot P + E_1 + E_2$$

- L: Total rail length [mm]
- n: Number of fixing holes
- P: Distance between two fixing holes [mm]
- $E_{1/2}$: Distance from the center of the last fixing hole to the end of the rail [mm]

1.3.15.5 Tightening torques for fixing screws

Insufficient tightening of the fixing screws will highly detract from the accuracy of the linear guideway; the following tightening torques are recommended for the respective screw sizes.

Table 1.41 Tightening torques for fixing screws to ISO 4762-12.9

Series/Size	Screw size	Torque [Nm]	Series/Size	Screw size	Torque [Nm]
EG_15	M3 × 16	2	EG_30	M6 × 25	13
EG_15U	M4 × 16	4	EG_30U	M8 × 25	30
EG_20	M5 × 16	9	EG_35	M8 × 25	30
EG_25	M6 × 20	13			

1.3.15.6 Cover cap for rail fixing holes

The cover caps are used to keep the fixing holes free from chips and dirt. The standard plastic bolt caps are enclosed to each rail. Optional caps have to be ordered extra.

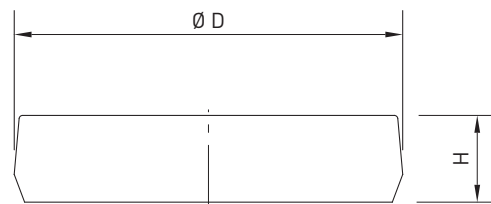

Table 1.42 Cover cap for rail fixing holes

Rail	Screw	Article number			Ø D [mm]	Height H [mm]
		Plastic	Brass	Steel		
EGR15R	M3	C3	C3-M	—	6,0	1,2
EGR20R	M5	C5	C5-M	C5-ST	9,5	2,2
EGR25R	M6	C6	C6-M	C6-ST	11,0	2,5
EGR30R	M6	C6	C6-M	C6-ST	11,0	2,5
EGR35R	M8	C8	C8-M	C8-ST	14,0	3,3
EGR15U	M4	C4	C4-M	—	7,5	1,1
EGR30U	M8	C8	C8-M	C8-ST	14,0	3,3

Linear Guideways

QH/QE series

1.4 Linear Guideway Series QH/QE

1.4.1 Special characteristics of the linear guideway series QH/QE

The development of the QH/QE series is based on the established four-row HG and EG series with arc profile. The series QH/QE with SynchMotion™-Technology owns all the technical advantages of the standard models and also offers a very smooth running, improved lubrication and a optimal synchronous run. This offers versatile application possibilities in industry sectors which requires high performance specifications and smoothness. Dimensionally identical and compatible with the HG- or EG-blocks, the blocks with SynchMotion™ technology are mounted on the standard rails and are therefore very easy to replace.

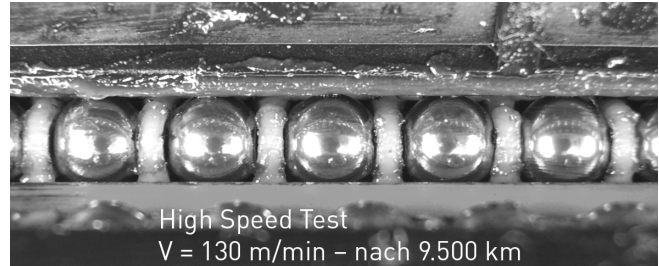

High speed load test

1.4.2 Construction of the QH/QE series

- 4-row recirculating ball bearing guide
- 45° contact angle of the ball tracks
- SynchMotion™-Technology
- Different sealing variants, depending on application area

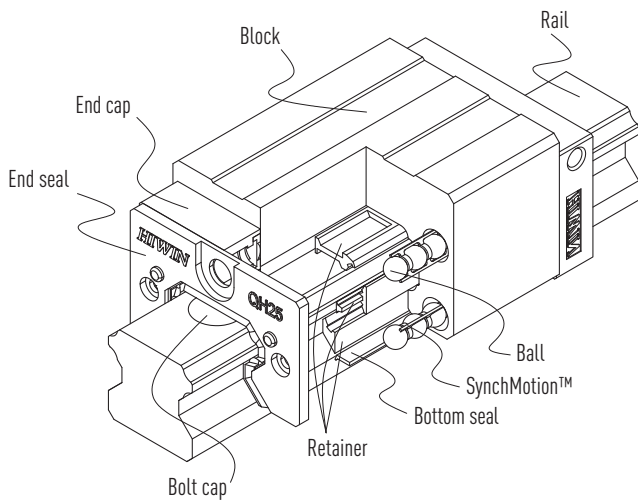

Construction of the QH series

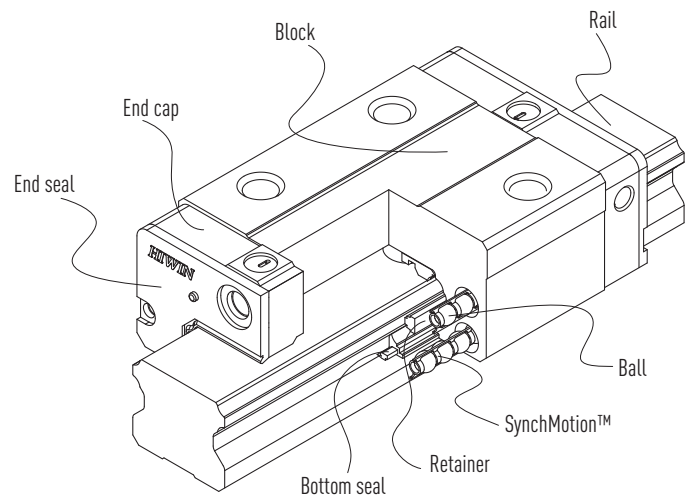

Construction of the QE series

1.4.3 Advantages

- Free of play
- Low noise level by SynchMotion™-Technology
- Very good synchronous performance
- High positioning accuracy
- Longer lubrication interval

1.4.4 Article numbers for the QH/QE series

QH/QE linear guideways are available as either interchangeable or non-interchangeable versions. The dimensions of both models are identical. The interchangeable models are more user friendly, as the block and rail can be replaced freely. However, accuracy is lower than that of the non-interchangeable models.

Due to the strict control of dimensional accuracy, the interchangeable models are a good choice for customers not using pairs of rails on a stage. The article numbers include the dimensions, model, accuracy class and preload class etc.

1.4.4.1 Non-interchangeable models (customized models)

○ Item number of the fully installed linear guideway

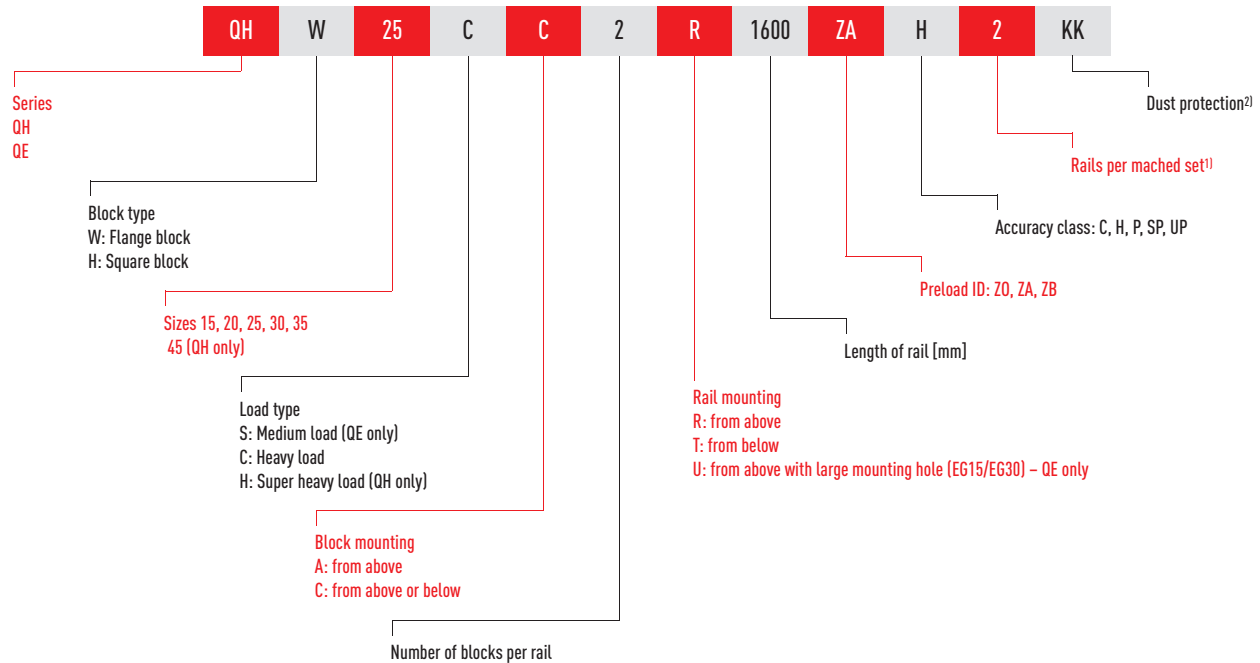

1.4.4.2 Interchangeable models

○ Article number of the QH/QE block

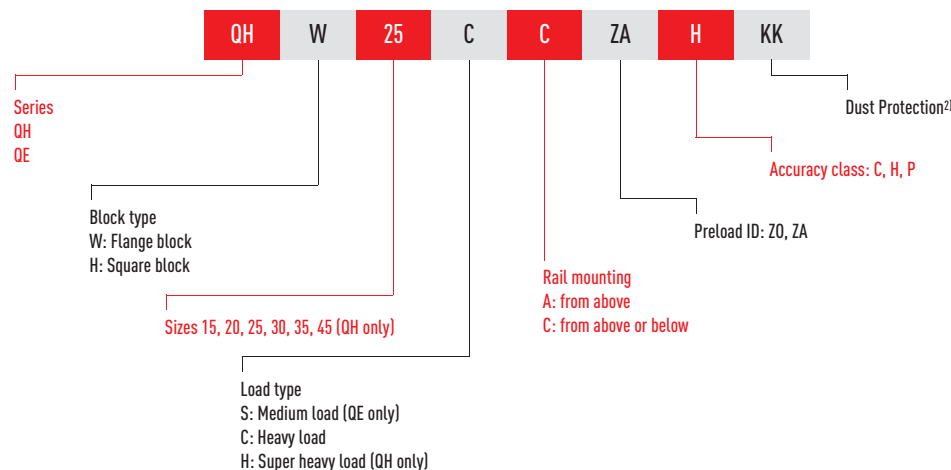

Note:

1) Figure 2 is also a quantity statement, i.e. a part of the article described above consists of a pair of rails. No figures are provided for individual linear guideways.

2) No information is provided for the standard version for dust protection (end seal and bottom seal)

ZZ: End seal, bottom seal and scraper

KK: Double seals, bottom seal and scraper

DD: Double seals and bottom seal

Linear Guideways

QH/QE series

- Article numbers of the HG/EG rail
QH and HG share the identical rails.
QE and EG share the identical rails.

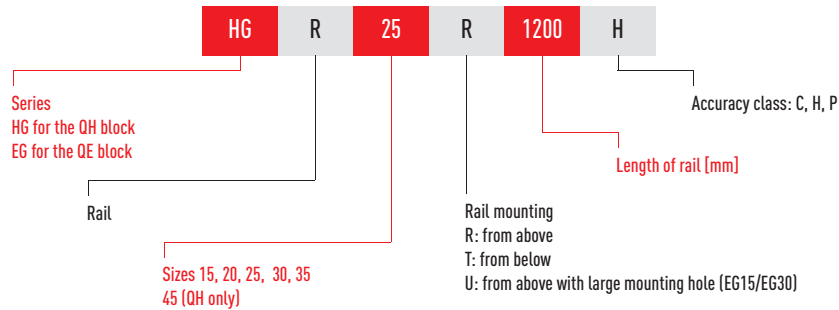

1.4.5 Preload

1.4.5.1 Definition

A preload can be applied to any rails version. For this purpose, oversized balls are used. Normally a linear guideway has a negative clearance between the path and the ball bearings, to increase rigidity and precision. The curve shows that rigidity doubles with a high preload. A preload not larger than ZA would be recommended for all model sizes under 20 to avoid a reduction of service life.

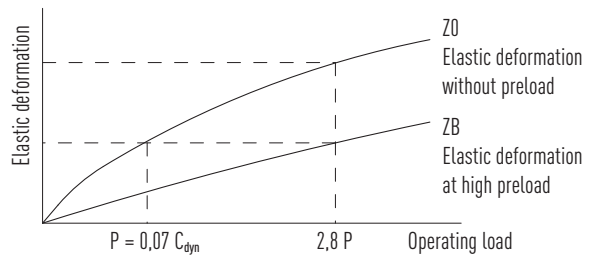

1.4.5.2 Preload ID

Table 1.43 Preload ID

ID	Preload		Application	Example applications
Z0	Light preload	0 – 0,02 C _{dyn}	Constant load direction, low impacts, low accuracy required	Transportation technology, automatic packaging machinery, X-Y stages for industrial machinery, automated welding
ZA	Light to medium preload	QE: 0,03 – 0,05 C _{dyn}	High accuracy required	Machining centers, Z stages for industrial machinery, erosion machinery, NC lathes, precision X-Y benches, measuring technology
	Medium preload	QH: 0,05 – 0,07 C _{dyn}		
ZB	High preload	QE: 0,06 – 0,08 C _{dyn}	High rigidity required, with vibrations and impacts	Machining centers, grinding machinery, NC lathes, horizontal and vertical milling machinery, Z stage of machine tools, high-performance cutting machinery
	Very high preload	QH: 0,1 – 0,12 C _{dyn}		

Note:

Preload classes for interchangeable versions Z0 and ZA. For non-interchangeable versions: Z0, ZA, ZB.

1.4.6 Accuracy classes

The QH/QE series is divided into five classes according to respective accuracy – normal (C), high (H), precision class (P), super precision class (SP) and ultra precision class (UP).

The requirements of the machinery in which the linear guideway is used, determine the selection.

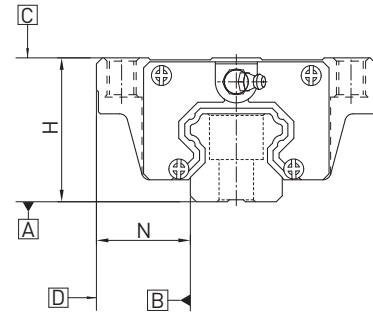

1.4.6.1 Accuracy classes of non-interchangeable types

Parallelism of block surface C with surface A, see table 1.46

Parallelism of block surface D with surface B, see table 1.46

Table 1.44 Tolerances depending on the accuracy class

Series/Size	Accuracy class	Height tolerance of H ¹⁾	Width tolerance of N ¹⁾	Height variance of H ²⁾	Width variance of N ²⁾
QH_15, 20 QE_15, 20	Normal (C)	± 0,1	± 0,1	0,02	0,02
	High (H)	± 0,03	± 0,03	0,01	0,01
	Precision (P)	0 - 0,03	0 - 0,03	0,006	0,006
	Super precision (SP)	0 - 0,015	0 - 0,015	0,004	0,004
	Ultra precision (UP)	0 - 0,008	0 - 0,008	0,003	0,003
QH_25, 30, 35 QE_25, 30, 35	Normal (C)	± 0,1	± 0,1	0,02	0,03
	High (H)	± 0,04	± 0,04	0,015	0,015
	Precision (P)	0 - 0,04	0 - 0,04	0,007	0,007
	Super precision (SP)	0 - 0,02	0 - 0,02	0,005	0,005
	Ultra precision (UP)	0 - 0,01	0 - 0,01	0,003	0,003
QH_45	Normal (C)	± 0,1	± 0,1	0,03	0,03
	High (H)	± 0,05	± 0,05	0,015	0,02
	Precision (P)	0 - 0,05	0 - 0,05	0,007	0,01
	Super precision (SP)	0 - 0,03	0 - 0,03	0,005	0,007
	Ultra precision (UP)	0 - 0,02	0 - 0,02	0,003	0,005

Unit: mm

¹⁾ Tolerance data that applies to any rail with any block

²⁾ Permissible absolute dimensional deviation between several blocks distributed over one individual rail or located on a pair of rails

Linear Guideways

QH/QE series

1.4.6.2 Accuracy classes of interchangeable types

Parallelism of block surface C with surface A, see table 1.46

Parallelism of block surface D with surface B, see table 1.46

Table 1.45 Tolerances depending on the accuracy class

Series/Size	Accuracy class	Height tolerance of H ¹⁾	Width tolerance of N ¹⁾	Height variance of H ²⁾	Width variance of N ²⁾
QH_15, 20 QE_15, 20	Normal (C)	± 0,1	± 0,1	0,02	0,02
	High (H)	± 0,03	± 0,03	0,01	0,01
	Precision (P)	± 0,015	± 0,015	0,006	0,006
QH_25, 30, 35 QE_25, 30, 35	Normal (C)	± 0,1	± 0,1	0,02	0,03
	High (H)	± 0,04	± 0,04	0,015	0,015
	Precision (P)	± 0,02	± 0,02	0,007	0,007
QH_45	Normal (C)	± 0,1	± 0,1	0,03	0,03
	High (H)	± 0,05	± 0,05	0,015	0,02
	Precision (P)	± 0,025	± 0,025	0,007	0,01

Unit: mm

¹⁾ Tolerance data that applies to any block on any rail

²⁾ Permissible absolute dimensional deviation between several blocks, distributed over one individual rail or located on a pair of rails

Table 1.46 Tolerance parallelism between block and rail

Rail length [mm]	Accuracy class				
	C	H	P	SP	UP
- 100	12	7	3	2	2
100 - 200	14	9	4	2	2
200 - 300	15	10	5	3	2
300 - 500	17	12	6	3	2
500 - 700	20	13	7	4	2
700 - 900	22	15	8	5	3
900 - 1100	24	16	9	6	3
1100 - 1500	26	18	11	7	4
1500 - 1900	28	20	13	8	4
1900 - 2500	31	22	15	10	5
2500 - 3100	33	25	18	11	6
3100 - 3600	36	27	20	14	7
3600 - 4000	37	28	21	15	7

Unit: µm

1.4.7 Dust protection

A variety of sealing systems are available for the HIWIN sliding carriage. You will find an overview of these on page 87. In the following table, the overall lengths of the sliding carriages with different sealing systems are listed. The corresponding sealing systems are available for these design sizes.

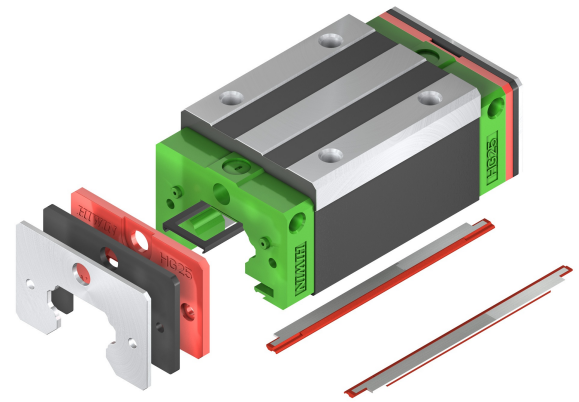
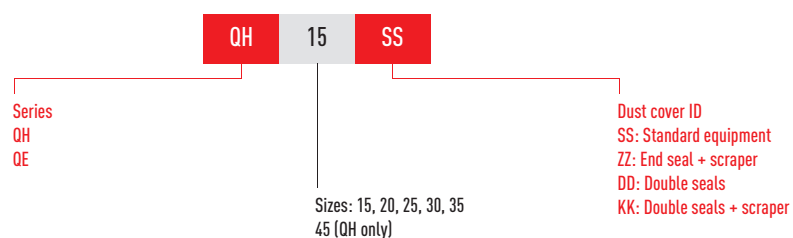

Table 1.47 The overall length of the sliding carriage with different sealing systems

Series Size	Gesamtlänge L					
	SS	DD	ZZ	KK	SW	ZWX
HG_15C	61,4	68,0	68,4	75,0	—	—
HG_20C	76,7	81,7	81,9	86,9	—	—
HG_20H	91,4	96,4	96,6	101,6	—	—
HG_25C	83,4	88,4	89,4	94,4	—	—
HG_25H	104,0	109,0	110,0	115,0	—	—
HG_30C	97,4	104,8	104,8	112,2	—	—
HG_30H	120,4	127,8	127,8	135,2	—	—
HG_35C	113,6	118,6	119,0	124,0	—	—
HG_35H	139,4	144,4	144,8	149,8	—	—
HG_45C	139,4	146,6	147,2	154,4	—	—
HG_45H	171,2	178,4	179,0	186,2	—	—
HG_55H	40,1	44,1	42,1	46,1	—	—
HG_65C	56,8	60,8	58,8	62,8	—	—
HG_65H	50,0	54,0	52,0	56,0	—	—
QE_20C	69,1	73,1	71,1	75,1	—	—
QE_25S	60,1	65,1	62,1	67,1	—	—
QE_25C	83,6	88,6	85,6	90,6	—	—
QE_30S	67,5	72,5	69,5	74,5	—	—
QE_30C	96,1	101,1	98,1	103,1	—	—
QE_35S	76,0	80,0	79,0	83,0	—	—
QE_35C	108,0	112,0	111,0	115,0	—	—

1.4.7.1 Designation of the seal sets

The seal sets are always shipped complete with the installation materials and include the supplemental parts for the standard seal.



Linear Guideways

QH/QE series

1.4.8 Friction

The table shows the maximum frictional resistance of the single endseal. Depending on the seal arrangement (SS, ZZ, DD, KK), the value has to be multiplied accordingly. The specified values apply to blocks on uncoated rails. Higher frictional forces occur on coated rails.

Table 1.49 Frictional resistance of the single-lip seals

Series/Size	Resistance [N]	Series/Size	Resistance [N]
QH_15	1,2	QE_15	1,1
QH_20	1,6	QE_20	1,4
QH_25	2,0	QE_25	1,7
QH_30	2,7	QE_30	2,1
QH_35	3,1	QE_35	2,3
QH_45	5,3		

1.4.9 The accuracy tolerance of rail-mounting surface

Because of the circular-arc contact design, the QH/QE linear guideway can compensate for some surface-error on installation and still maintain smooth linear motion. As long as the accuracy requirements for the mounting surface are followed, high accuracy and rigidity of linear motion of the guideway can be obtained without any difficulty. In order to satisfy the needs of fast installation and smooth movement, HIWIN offers the normal clearance type of preload to customers of its high absorption ability of the deviation in mounting surface accuracy.

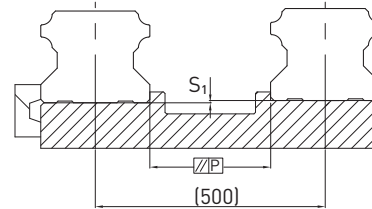

Parallelism tolerance of reference surface (P)

Table 1.50 Maximum tolerances for the parallel alignment (P)

Series/Size	Load class		
	Z0	ZA	ZB
QH/QE_15	25	18	—
QH/QE_20	25	20	18
QH/QE_25	30	22	20
QH/QE_30	40	30	27
QH/QE_35	50	35	30
QH_45	60	40	35

Unit: μm

Table 1.51 Maximum tolerance of reference surface height (S_1)

Series/Size	Load class		
	Z0	ZA	ZB
QH/QE_15	130	85	—
QH/QE_20	130	85	50
QH/QE_25	130	85	70
QH/QE_30	170	110	90
QH/QE_35	210	150	120
QH_45	250	170	140

Unit: μm

1.4.10 Shoulder heights and fillets

Improper shoulder heights and fillets of mounting surfaces will cause a deviation in accuracy and the interference with the chamfered part of the rail or block. As long as the recommended shoulder heights and fillets are followed, installation inaccuracies should be eliminated.

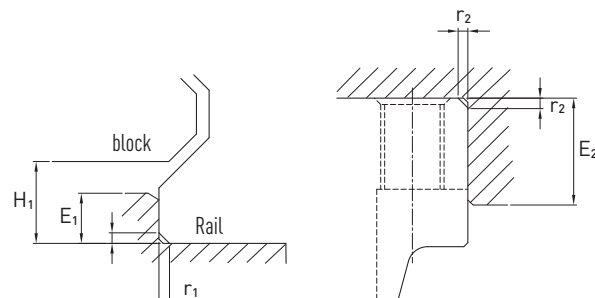

Linear Guideways

QH/QE series

Table 1.52 Shoulder heights and fillets

Series/Size	Max. radius of fillets r_1	Max. radius of fillets r_2	Shoulder height of the rail E_1	Shoulder height of the block E_2	Clearance under block H_1
QH_15	0,5	0,5	3,0	4,0	4,0
QH_20	0,5	0,5	3,5	5,0	4,6
QH_25	1,0	1,0	5,0	5,0	5,5
QH_30	1,0	1,0	5,0	5,0	6,0
QH_35	1,0	1,0	6,0	6,0	7,5
QH_45	1,0	1,0	8,0	8,0	9,5
QE_15	0,5	0,5	2,7	5,0	4,5
QE_20	0,5	0,5	5,0	7,0	6,0
QE_25	1,0	1,0	5,0	7,5	7,0
QE_30	1,0	1,0	7,0	7,0	10,0
QE_35	1,0	1,5	7,5	9,5	11,0

Unit: mm

1.4.11 Load ratings and torques

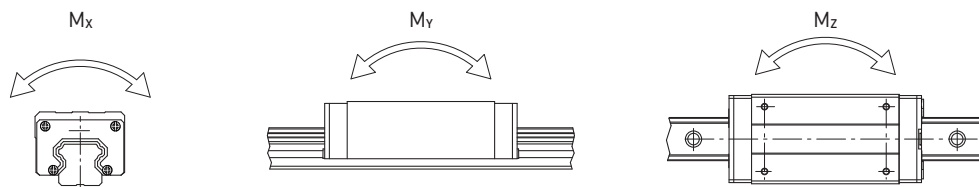

Table 1.53 Load ratings and torques series QH/QE

Series/Size	Dynamic load C_{dyn} [N]*	Static load C_0 [N]	Dynamic moment [Nm]			Static moment [Nm]		
			M_x	M_y	M_z	M_{0x}	M_{0y}	M_{0z}
QH_15C	13880	14360	90	84	84	100	80	80
QH_20C	23080	25630	231	171	171	260	190	190
QH_20H	27530	31670	268	230	230	310	270	270
QH_25C	31780	33680	361	294	294	390	310	310
QH_25H	39300	43620	451	410	410	500	450	450
QH_30C	46490	48170	588	491	491	600	500	500
QH_30H	56720	65090	722	623	623	830	890	890
QH_35C	60520	63840	1019	720	720	1070	760	760
QH_35H	73590	86240	1233	1135	1135	1450	1330	1330
QH_45C	89210	94810	1723	1295	1295	1830	1380	1380
QH_45H	108720	128430	2097	2041	2041	2470	2410	2410
QE_15S	8560	8790	68	29	29	70	30	30
QE_15C	12530	15280	98	73	73	120	90	90
QE_20S	11570	12180	123	47	47	130	50	50
QE_20C	16500	20210	171	122	122	210	150	150
QE_25S	18240	18900	212	96	96	220	100	100
QE_25C	26030	31490	305	239	239	370	290	290
QE_30S	26270	27820	377	169	169	400	180	180
QE_30C	37920	46630	544	414	414	670	510	510
QE_35S	36390	36430	609	330	330	610	330	330
QE_35C	51180	59280	863	648	648	1000	750	750

* Dynamic load rating for 50,000 m travel path

1.4.12 Rigidity

Rigidity is dependent on the preload. Using formula 1.1, it is possible to determine the deformation in relation to the rigidity.

$$\delta = \frac{P}{k}$$

δ: deformation [μm]

P: Operating load [N]

k: Rigidity value [N/μm]

Formula 1.1

Table 1.54 Radial rigidity series QH/QE

Load class	Series Size	Preload		
		Z0	ZA	ZB
Heavy load	QH_15C	180	230	260
	QH_20C	230	290	320
	QH_25C	270	350	400
	QH_30C	330	430	500
	QH_35C	370	480	550
	QH_45C	460	590	680
Super heavy load	QH_20H	280	360	410
	QH_25H	350	460	520
	QH_30H	430	560	640
	QH_35H	480	620	710
	QH_45H	590	770	870
Medium load	QE_15S	96	115	128
	QE_20S	116	139	153
	QE_25S	137	165	184
	QE_30S	169	203	226
	QE_35S	214	257	287
Heavy load	QE_15C	157	187	209
	QE_20C	183	219	245
	QE_25C	219	263	293
	QE_30C	271	326	363
	QE_35C	333	399	445

Linear Guideways

QH/QE series

1.4.13 Dimensions of the QH block

1.4.13.1 QHH-CA / QHH-HA

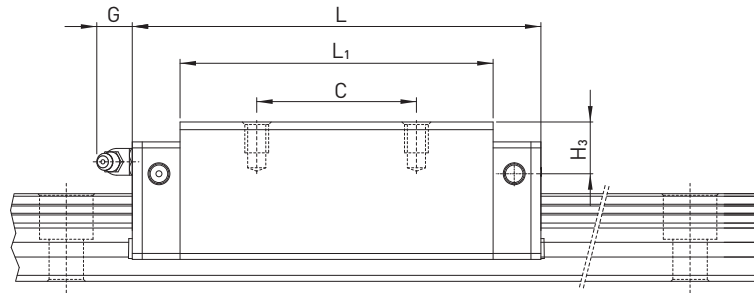
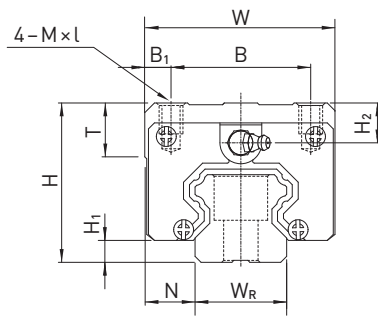

Table 1.55 Dimensions of the block

Series Size	Installation dim. [mm]			Dimensions of the block [mm]												Load Ratings [N]		Mass [kg]
	H	H ₁	N	W	B	B ₁	C	L ₁	L	G	M × l	T	H ₂	H ₃	C _{dyn}	C ₀		
QHH15CA	28	4,0	9,5	34	26,0	4,0	26	39,4	61,4	5,3	M4 × 5	6,0	7,95	8,2	13880	14360	0,18	
QHH20CA	30	4,6	12,0	44	32,0	6,0	36	50,5	76,7	12,0	M5 × 6	8,0	6,00	6,0	23080	25630	0,29	
QHH20HA							50	65,2	91,4						27530	31670	0,38	
QHH25CA	40	5,5	12,5	48	35,0	6,5	35	58,0	83,4	12,0	M6 × 8	8,0	10,00	9,0	31780	33680	0,50	
QHH25HA							50	78,6	104,0						39300	43620	0,68	
QHH30CA	45	6,0	16,0	60	40,0	10,0	40	70,0	97,4	12,0	M8 × 10	8,5	9,50	9,0	46490	48170	0,87	
QHH30HA							60	93,0	120,4						56720	65090	1,15	
QHH35CA	55	7,5	18,0	70	50,0	10,0	50	80,0	113,6	12,0	M8 × 12	10,2	15,50	13,5	60520	63840	1,44	
QHH35HA							72	105,8	139,4						73590	86240	1,90	
QHH45CA	70	9,2	20,5	86	60,0	13,0	60	97,0	139,4	12,9	M10 × 17	16,0	18,50	20,0	89210	94810	2,72	
QHH45HA							80	128,8	171,2						108720	128430	3,59	

Dimensions of the rail see page 20, standard- and optional lubrication adapters see page 84.

1.4.13.2 QHW-CC / QHW-HC

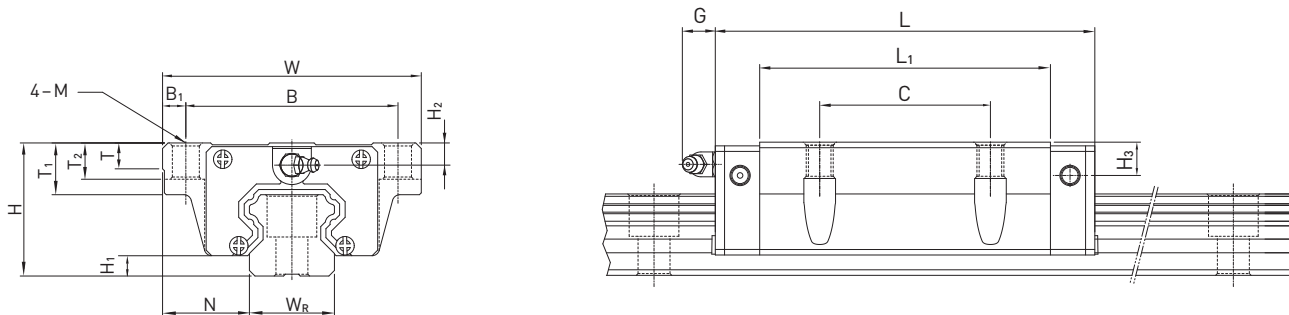

Table 1.56 Dimensions of the block

Series Size	Installation dim. [mm]			Dimensions of the block [mm]													Load Ratings [N]		Mass [kg]
	H	H ₁	N	W	B	B ₁	C	L ₁	L	G	M	T	T ₁	T ₂	H ₂	H ₃	C _{dyn}	C ₀	
QHW15CC	24	4,0	16,0	47	38	4,5	30	39,4	61,4	5,3	M5	6,0	8,9	6,95	3,95	4,2	13880	14360	0,17
QHW20CC	30	4,6	21,5	63	53	5,0	40	50,5	76,7	12,0	M6	8,0	10,0	9,5	6,00	6,0	23080	25630	0,40
QHW20HC								65,2	91,4								27530	31670	0,52
QHW25CC	36	5,5	23,5	70	57	6,5	45	58,0	83,4	12,0	M8	8,0	14,0	10,0	6,00	5,0	31780	33680	0,59
QHW25HC								78,6	104,0								39300	43620	0,80
QHW30CC	42	6,0	31,0	90	72	9,0	52	70,0	97,4	12,0	M10	8,5	16,0	10,0	6,50	6,0	46490	48170	1,09
QHW30HC								93,0	120,4								56720	65090	1,44
QHW35CC	48	7,5	33,0	100	82	9,0	62	80,0	113,6	12,0	M10	10,1	18,0	13,0	8,50	6,5	60520	63840	1,56
QHW35HC								105,8	139,4								73590	86240	2,06
QHW45CC	60	9,2	37,5	120	100	10,0	80	97,0	139,4	12,9	M12	15,1	22,0	15,0	8,50	10,0	89210	94810	2,79
QHW45HC								128,8	171,2								108720	128430	3,69

Dimensions of the rail see page 20, standard- and optional lubrication adapters see page 84.

Linear Guideways

QH/QE series

1.4.14 Dimensions of the QE block

1.4.14.1 QEH-SA / QEH-CA

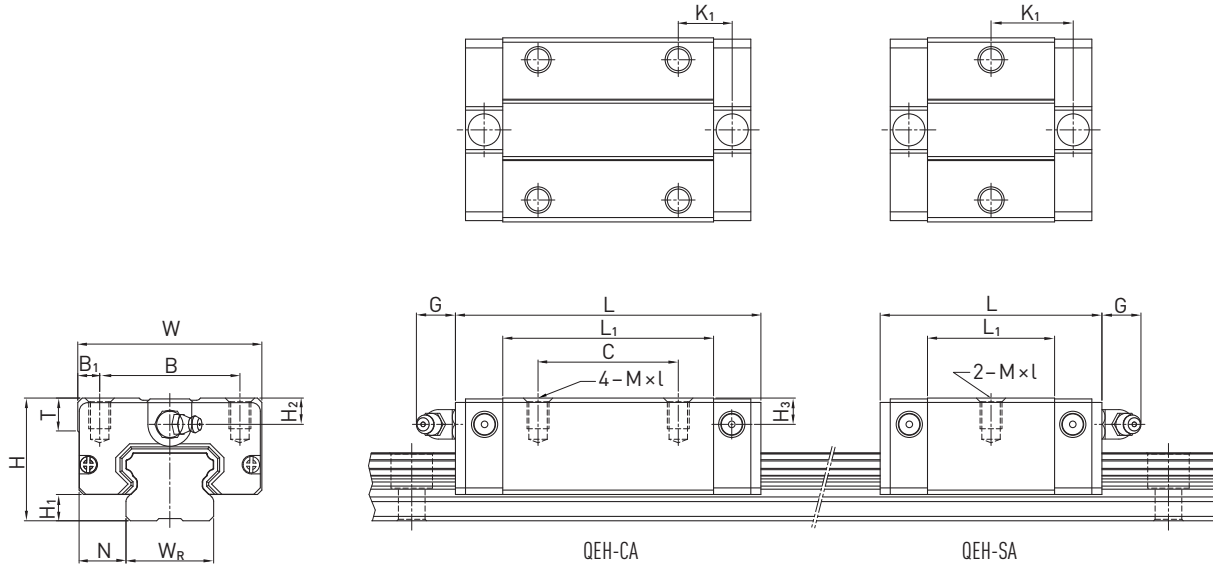

Table 1.57 Dimensions of the block

Series Size	Installation dim. [mm]			Dimensions of the block [mm]												Load Ratings [N]		Mass [kg]
	H	H ₁	N	W	B	B ₁	C	L ₁	L	K ₁	G	M × l	T	H ₂	H ₃	C _{dyn}	C ₀	
QEH15SA	24	4,0	9,5	34	26	4,0	0	23,1	40,1	14,80	5,7	M4 × 6	6,0	5,50	6,0	8560	8790	0,09
QEH15CA							26	39,8	56,8	10,15						12530	15280	0,15
QEH20SA	28	6,0	11,0	42	32	5,0	0	29,0	50,0	18,75	12,0	M5 × 7	7,5	6,00	6,5	11570	12180	0,15
QEH20CA							32	48,1	69,1	12,30						16500	20210	0,23
QEH25SA	33	6,2	12,5	48	35	6,5	0	35,5	60,1	21,90	12,0	M6 × 9	8,0	8,00	8,0	18240	18900	0,24
QEH25CA							35	59,0	83,6	16,15						26030	31490	0,40
QEH30SA	42	10,0	16,0	60	40	10,0	0	41,5	67,5	25,75	12,0	M8 × 12	9,0	8,00	9,0	26270	27820	0,44
QEH30CA							40	70,1	96,1	20,05						37920	46630	0,75
QEH35SA	48	11,0	18,0	70	50	10,0	0	51,0	76,0	30,30	12,0	M8 × 12	10,0	8,50	8,5	36390	36430	0,58
QEH35CA							50	83,0	108,0	21,30						51180	59280	0,90

Dimensions of the rail see page 32, standard- and optional lubrication adapters see page 84.

1.4.14.2 QEW-SC / QEW-CC

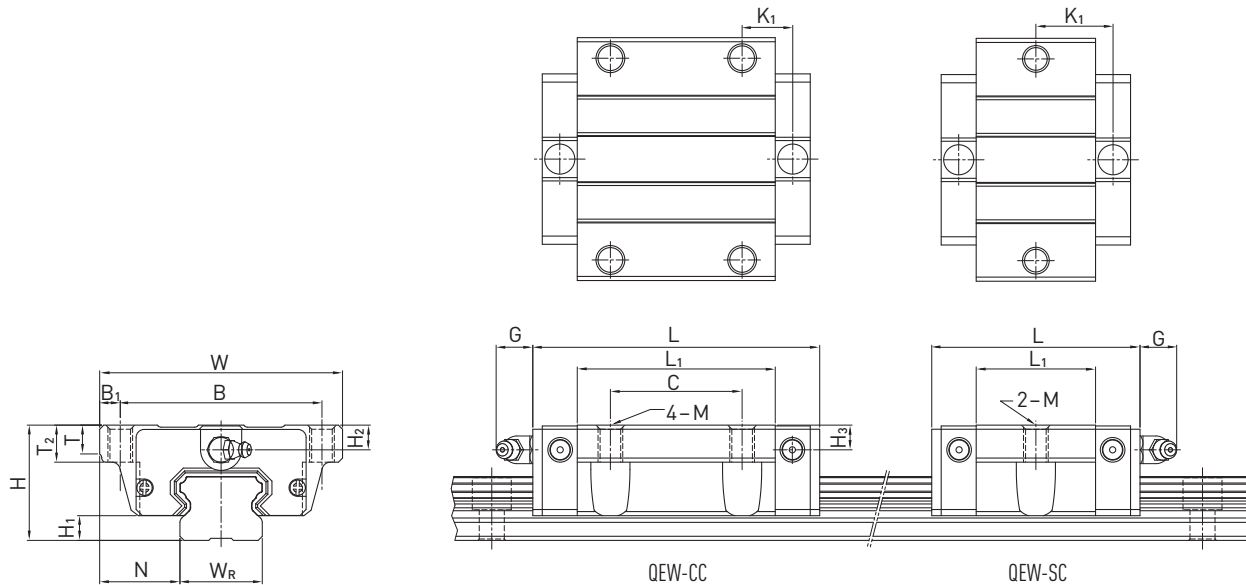

Table 1.58 Dimensions of the block

Series Size	Installation dim. [mm]			Dimensions of the block [mm]													Load Ratings [N]		Mass [kg]
	H	H ₁	N	W	B	B ₁	C	L ₁	L	K ₁	G	M	T	T ₂	H ₂	H ₃	C _{dyn}	C ₀	
QEW15SC	24	4,0	18,5	52	41	5,5	0	23,1	40,1	14,80	5,7	M5	5,0	7,0	5,50	6,0	8560	8790	0,12
QEW15CC							26	39,8	56,8	10,15							12530	15280	0,21
QEW20SC	28	6,0	19,5	59	49	5,0	0	29,0	50,0	18,75	12,0	M6	7,0	9,0	6,00	6,5	11570	12180	0,19
QEW20CC							32	48,1	69,1	12,30							16500	20210	0,31
QEW25SC	33	6,2	25,0	73	60	6,5	0	35,5	60,1	21,90	12,0	M8	7,5	10,0	8,00	8,0	18240	18900	0,34
QEW25CC							35	59,0	83,6	16,15							26030	31490	0,58
QEW30SC	42	10,0	31,0	90	72	9,0	0	41,5	67,5	25,75	12,0	M10	7,0	10,0	8,00	9,0	26270	27820	0,61
QEW30CC							40	70,1	96,1	20,05							37920	46630	1,03
QEW35SC	48	11,0	33,0	100	82	9,0	0	51,0	76,0	30,30	12,0	M10	10,0	13,0	8,50	8,5	36390	36430	0,77
QEW35CC							50	83,0	108,0	21,30							51180	59280	1,19

Dimensions of the rail see page 32, standard- and optional lubrication adapters see page 84.

Linear Guideways

WE series

1.5 Linear Guideway Series WE

1.5.1 Special characteristics of the linear guideway series WE

The WE series features equal load ratings in the radial, reverse radial and the lateral direction with contact points at 45 degrees. This along with the wide rail, allows the guideway to be rated for high loads, moments and rigidity. By design, it has a self-aligning capacity that can absorb most installation errors and can meet high accuracy standards. The ability to use a single rail and to have the low profile with a low center of gravity is ideal where space is limited and/or high moments are required.

1.5.2 Construction of the WE series

- 4-row recirculating ball bearing guide
- 45° contact angle of the ball tracks
- The ball retainers prevent the balls from falling out when the carriage is removed
- Lower assembly height
- Wide guideway for high torque capacity
- Large mounting surface on the block

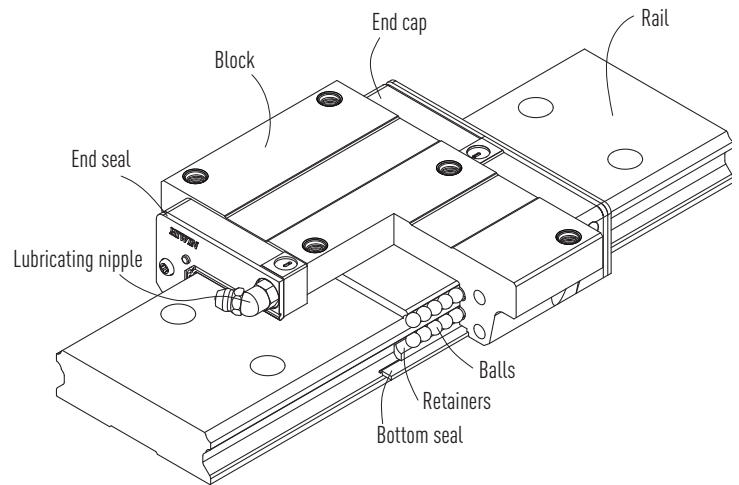
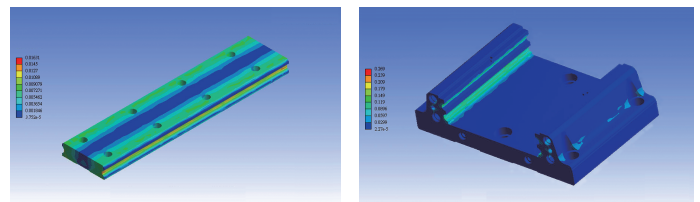
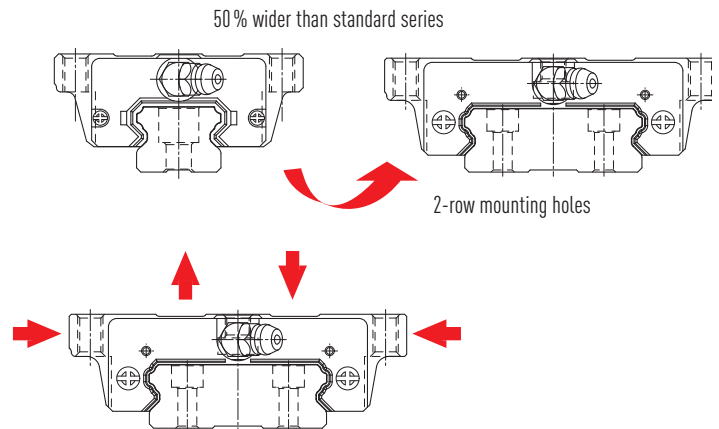

Fig. Construction of the WE series

1.5.3 Advantages

- Compact and economical design caused by high torque capacity
- High efficiency due to low frictional losses
- The large mounting surface of the block supports the transmission of higher torques
- High load capacity in all directions by contact points at 45°
- Optimized geometry and high load capacity by FEM-Analysis of rail and block



1.5.4 Article numbers for the WE series

Linear guideways are available as either interchangeable or non-interchangeable versions. The dimensions of both models are identical. The interchangeable models are more user friendly, as the block and rail can be replaced freely. However, accuracy is lower than that of the non-interchangeable models.

Due to the strict control of dimensional accuracy, the interchangeable models are a good choice for customers not using pairs of rails on a stage. The article numbers include the dimensions, model, accuracy class and preload class etc.

1.5.4.1 Non-interchangeable models (customized models)

- Item number of the fully installed linear guideway

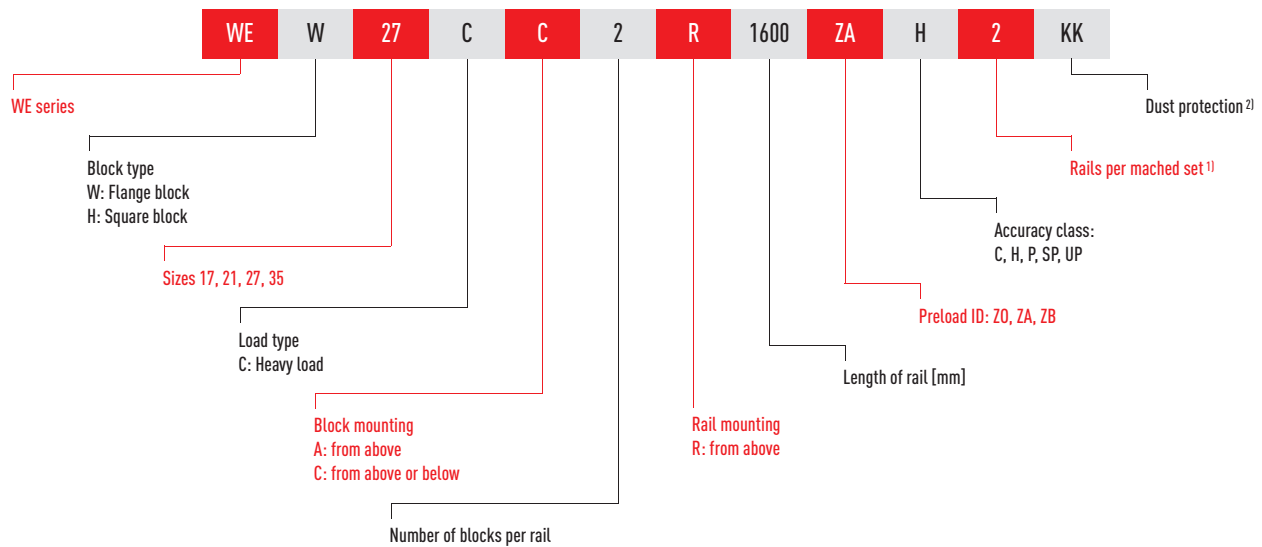

1.5.4.2 Interchangeable models

- Article number of the HG block

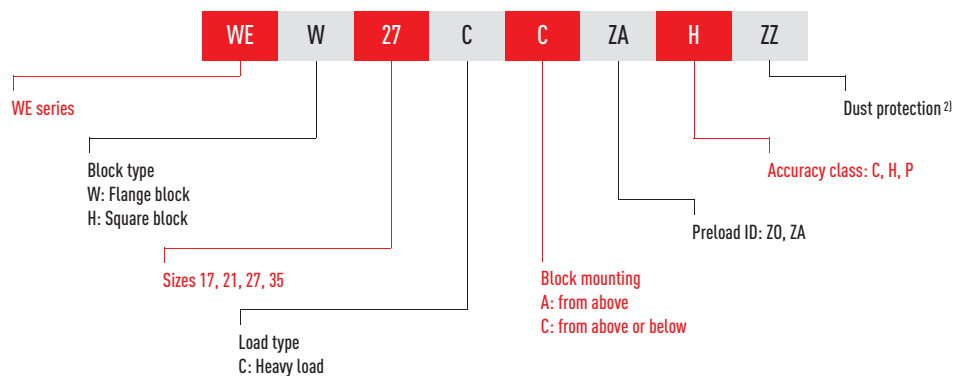

- Article number of the WE rail

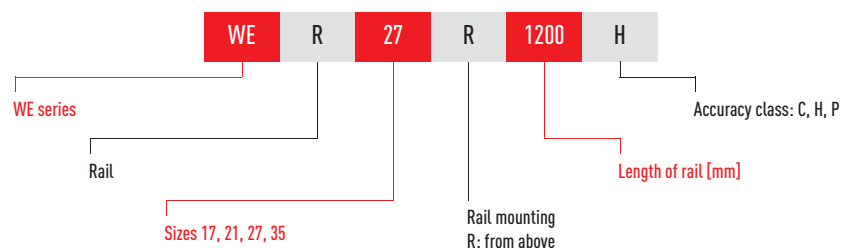

Note:

- Figure 2 is also a quantity statement, i.e. a part of the article described above consists of a pair of rails. No figures are provided for individual linear guideways.
- No information is provided for the standard version for dust protection (end seal and bottom seal)
 ZZ: End seal, bottom seal and scraper
 KK: Double seals, bottom seal and scraper
 DD: Double seals and bottom seal

Linear Guideways

WE series

1.5.5 Block types

HIWIN offers square blocks and flange blocks for its linear guideways. The low assembly height and larger installation surface makes flange blocks more suitable for heavy loads.

Table 1.59 Block types

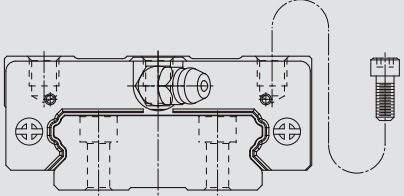
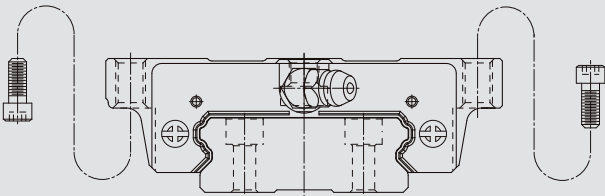
Type	Series Size	Construction	Height [mm]	Rail length [mm]	Typical application
Square	WEH-CA		17 – 35	100 – 4.000	<ul style="list-style-type: none"> ○ Automation devices ○ High-speed transportation equipment ○ Precision measuring equipment ○ Semiconductor manufacturing equipment ○ Blow moulding machines ○ Single axis robot-robotics ○ Single axis equipment with high anti-rolling requirement
Flange	WEW-CC				

1.5.6 Preload

1.5.6.1 Definition

A preload can be applied to any rails version. For this purpose, oversized balls are used. Normally a linear guideway has a negative clearance between the path and the ball bearings, to increase rigidity and precision. The curve shows that rigidity doubles with a high preload.

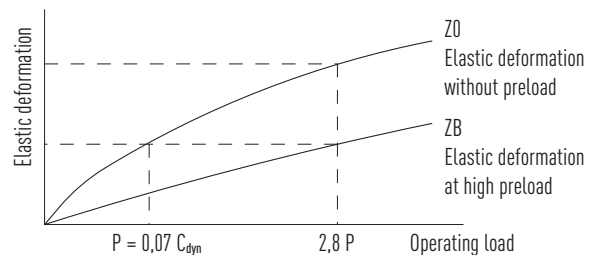

1.5.6.2 Preload ID

Table 1.60 Preload ID

ID	Preload		Application
Z0	Light preload	0 – 0,02 C	Constant load direction, low impacts, low accuracy required
ZA	Medium preload	0,03 – 0,05 C	High accuracy required
ZB	High preload	0,06 – 0,08 C	High rigidity required, with vibrations and impacts

Note:

Preload classes for interchangeable versions Z0 and ZA. For non-interchangeable versions: Z0, ZA, ZB.

1.5.7 Accuracy classes

The WE series is divided in five classes by the respective precision accuracy: normal (C), high (H), precision (P), super precision (SP) and ultra precision (UP). The selection is determined by the requirement of the machine in which the guideway is used. The accuracy of the rails is determined by the straightness and flatness of the contact surfaces.

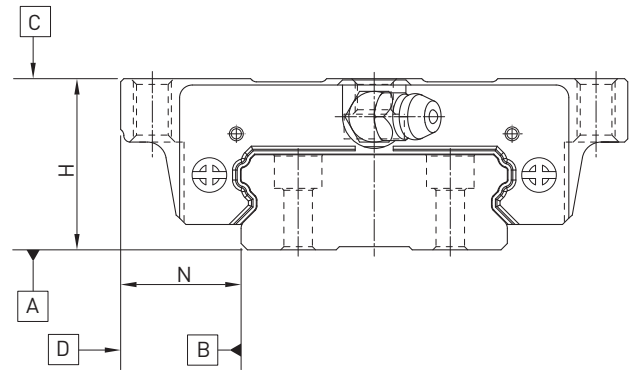

1.5.7.1 Accuracy classes of non-interchangeable types

Parallelism of block surface C with surface A, see table 1.63

Parallelism of block surface D with surface B, see table 1.63

Table 1.61 Tolerances depending on the accuracy class

Series/Size	Accuracy class	Height tolerance of H ¹⁾	Width tolerance of N ¹⁾	Height variance of H ²⁾	Width variance of N ²⁾
WE_17, 21	C (Normal)	± 0,1	± 0,1	0,02	0,02
	H (Hoch)	± 0,03	± 0,03	0,01	0,01
	P (Präzision)	0 -0,03	0 -0,03	0,006	0,006
	SP (Super-Präzision)	0 -0,015	0 -0,015	0,004	0,004
	UP (Ultra-Präzision)	0 -0,008	0 -0,008	0,003	0,003
WE_27, 35	Normal (C)	± 0,1	± 0,1	0,02	0,03
	High (H)	± 0,04	± 0,04	0,015	0,015
	Precision (P)	0 -0,04	0 -0,04	0,007	0,007
	Super precision (SP)	0 -0,02	0 -0,02	0,005	0,005
	Ultra precision (UP)	0 -0,01	0 -0,01	0,003	0,003

1.5.7.2 Accuracy classes of interchangeable types

Parallelism of block surface C with surface A, see table 1.63

Parallelism of block surface D with surface B, see table 1.63

Table 1.62 Tolerances depending on the accuracy class

Series/Size	Accuracy class	Height tolerance of H ¹⁾	Width tolerance of N ¹⁾	Height variance of H ²⁾	Width variance of N ²⁾
WE_17, 21	C (Normal)	± 0,1	± 0,1	0,02	0,02
	H (Hoch)	± 0,03	± 0,03	0,01	0,01
	P (Präzision)	± 0,015	± 0,015	0,006	0,006
WE_27, 35	Normal (C)	± 0,1	± 0,1	0,02	0,03
	High (H)	± 0,04	± 0,04	0,015	0,015
	Precision (P)	± 0,02	± 0,02	0,007	0,007

Unit: mm

¹⁾ Tolerance data that applies to any block on any rail

²⁾ Permissible absolute dimensional deviation between several blocks, distributed over one individual rail or located on a pair of rails

Linear Guideways

WE series

Table 1.63 Tolerance parallelism between block and rail

Rail length [mm]	Accuracy class				
	C	H	P	SP	UP
– 100	12	7	3	2	2
100 – 200	14	9	4	2	2
200 – 300	15	10	5	3	2
300 – 500	17	12	6	3	2
500 – 700	20	13	7	4	2
700 – 900	22	15	8	5	3
900 – 1100	24	16	9	6	3
1100 – 1500	26	18	11	7	4
1500 – 1900	28	20	13	8	4
1900 – 2500	31	22	15	10	5
2500 – 3100	33	25	18	11	6
3100 – 3600	36	27	20	14	7
3600 – 4000	37	28	21	15	7

Unit: μm

1.5.8 Dust protection

Table 1.64 The overall length of the sliding carriage with different sealing systems

Series Size	Gesamtlänge L					
	SS	DD	ZZ	KK	SW	ZWX
HG_20H	50,6	53,8	52,6	55,8	–	–
HG_25C	59,0	63,0	61,0	65,0	–	–
HG_15C	72,8	76,8	74,8	78,8	–	–
HG_20C	102,6	106,6	105,6	109,6	–	–

1.5.8.1 Designation of the seal sets

The seal sets are always shipped complete with the installation materials and include the supplemental parts for the standard seal.

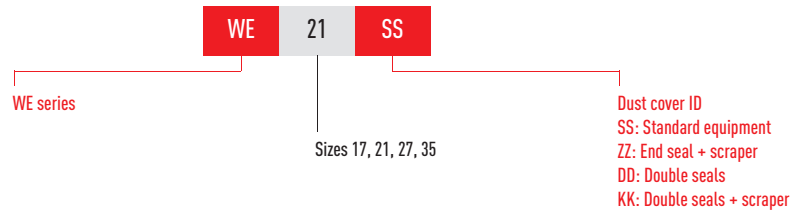

1.5.9 Friction

The table shows the maximum frictional resistance of the single end seal. Depending on the seal arrangement (SS, ZZ, DD, KK), the value has to be multiplied accordingly. The specified values apply to blocks on uncoated rails. Higher frictional forces occur on coated rails.

Table 1.66 Frictional resistance of the single-lip seals

Series/Size	Resistance [N]	Series/Size	Resistance [N]
WE_17	1,2	WE_27	2,9
WE_21	2,0	WE_35	3,9

1.5.10 The accuracy tolerance of rail-mounting surface

Because of the circular-arc contact design, the HG linear guideway can compensate for some surface-error on installation and still maintain smooth linear motion. As long as the accuracy requirements for the mounting surface are followed, high accuracy and rigidity of linear motion of the guideway can be obtained without any difficulty. In order to satisfy the needs of fast installation and smooth movement, HIWIN offers the normal clearance type of preload to customers of its high absorption ability of the deviation in mounting surface accuracy.

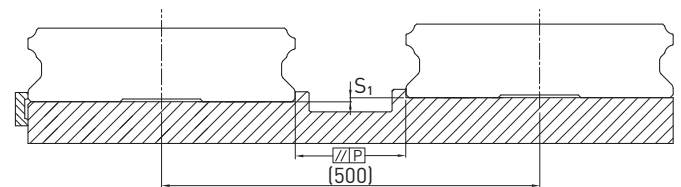

Parallelism tolerance of reference surface (P)

Table 1.67 Maximum tolerances for the parallel alignment (P)

Series/Size	Load class		
	Z0	ZA	ZB
WE_17	20	15	9
WE_21	25	18	9
WE_27	25	20	13
WE_35	30	22	20

Unit: µm

Table 1.68 Maximum tolerance of reference surface height (S₁)

Series/Size	Load class		
	Z0	ZA	ZB
WE_17	65	20	—
WE_21	130	85	45
WE_27	130	85	45
WE_35	130	85	70

Unit: µm

Linear Guideways

WE series

1.5.11 Shoulder heights and fillets

Improper shoulder heights and fillets of mounting surfaces will cause a deviation in accuracy and the interference with the chamfered part of the rail or block. As long as the recommended shoulder heights and fillets are followed, installation inaccuracies should be eliminated.

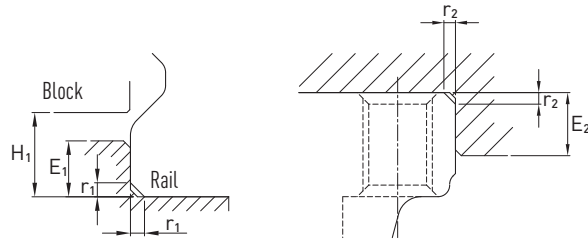

Table 1.69 Shoulder heights and fillets

Series/Size	Max. radius of fillets r_1	Max. radius of fillets r_2	Shoulder height of the rail E_1	Shoulder height of the block E_2	Clearance under block H_1
WE_17	0,4	0,4	2,5	4,0	3,0
WE_21	0,4	0,4	2,5	5,0	3,0
WE_27	0,5	0,4	2,5	7,0	4,0
WE_35	0,5	0,5	2,5	10,0	4,0

Unit: mm

1.5.12 Load ratings and torques

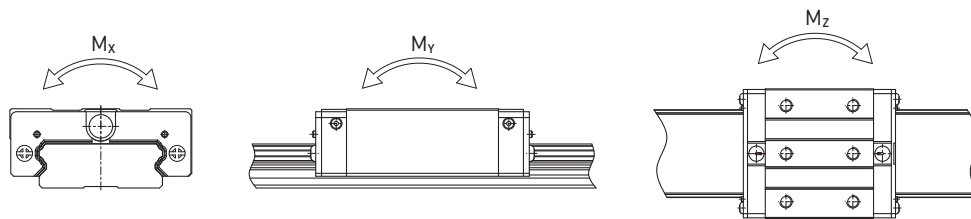

Table 1.70 Load ratings and torques for WE series

Series/Size	Dynamic load C_{dyn} [N]*	Static load C_0 [N]	Dynamic moment [Nm]			Static moment [Nm]		
			M_x	M_y	M_z	M_{0x}	M_{0y}	M_{0z}
HG_20H	5230	9640	82	34	34	150	62	62
HG_25C	7210	13700	122	53	53	230	100	100
WE_27C	12400	21600	242	98	98	420	170	170
WE_35C	29800	49400	893	405	405	1480	670	670

* Dynamic load rating for 50,000 m travel path

1.5.13 Rigidity

Rigidity is dependent on the preload. Using formula 1.1, it is possible to determine the deformation in relation to the rigidity.

$$\delta = \frac{P}{k}$$

δ : deformation [μm]

P: Operating load [N]

k: Rigidity value [N/ μm]

Formula 1.1

Table 1.71 Radial rigidity series WE

Load class	Series Size	Preload		
		Z0	ZA	ZB
Super heavy load	HG_20H	128	166	189
Heavy load	HG_25C	154	199	228
	WE_27C	187	242	276
	WE_35C	281	364	416

Unit: N/ μm

1.5.14 Dimensions of the WE block

1.5.14.1 WEH-CA

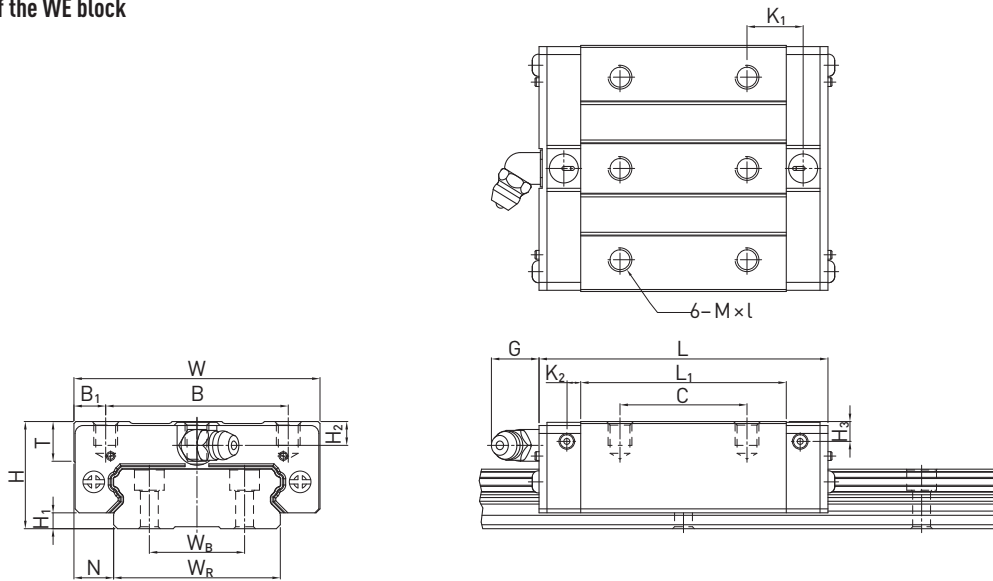

Table 1.72 Dimensions of the block

Series Size	Installation dim. [mm]			Dimensions of the block [mm]													Load Ratings [N]		Mass [kg]
	H	H ₁	N	W	B	B ₁	C	L ₁	L	K ₁	K ₂	G	M × l	T	H ₂	H ₃	C _{dyn}	C ₀	
WEH17CA	17	2,5	8,5	50	29,0	10,5	15	35,0	50,6	-	3,10	4,9	M4 × 5	6,0	4,00	3,0	5230	9640	0,12
WEH21CA	21	3,0	8,5	54	31,0	11,5	19	41,7	59,0	14,68	3,65	12,0	M5 × 6	8,0	4,50	4,2	7210	13700	0,20
WEH27CA	27	4,0	10,0	62	46,0	8,0	32	51,8	72,8	14,15	3,50	12,0	M6 × 6	10,0	6,00	5,0	12400	21600	0,35
WEH35CA	35	4,0	15,5	100	76,0	12,0	50	77,6	102,6	18,35	5,25	12,0	M8 × 8	13,0	8,00	6,5	29800	49400	1,10

Dimensions of the rail see page 57, standard- and optional lubrication adapters see page 84.

Linear Guideways

WE series

1.5.14.2 WEW-CC

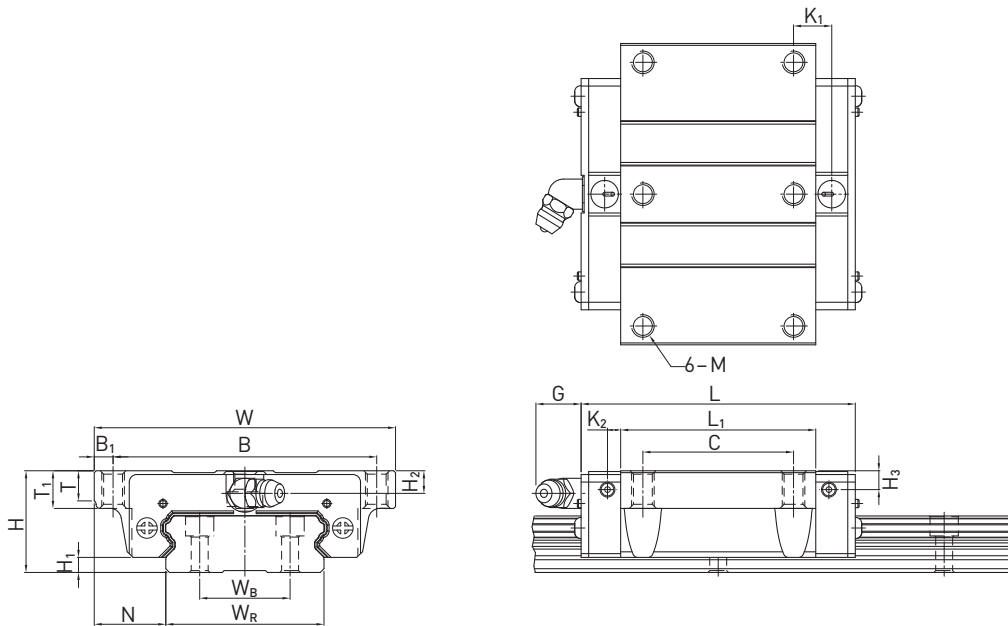

Table 1.73 Dimensions of the block

Series Size	Installation dim. [mm]			Dimensions of the block [mm]														Load Ratings [N]		Mass [kg]
	H	H ₁	N	W	B	B ₁	C	L ₁	L	K ₁	K ₂	G	M	T	T ₁	H ₂	H ₃	C _{dyn}	C ₀	
WEW17CC	17	2,5	13,5	60	53,0	3,5	26	35,0	50,6	0,00	3,10	4,9	M4	5,3	6,0	4,00	3,0	5230	9640	0,13
WEW21CC	21	3,0	15,5	68	60,0	4,0	29	41,7	59,0	9,68	3,65	12,0	M5	7,3	8,0	4,50	4,2	7210	13700	0,23
WEW27CC	27	4,0	19,0	80	70,0	5,0	40	51,8	72,8	10,15	3,50	12,0	M6	8,0	10,0	6,00	5,0	12400	21600	0,43
WEW35CC	35	4,0	25,5	120	107,0	6,5	60	77,6	102,6	13,35	5,25	12,0	M8	11,2	14,0	8,00	6,5	29800	49400	1,26

Dimensions of the rail see page 57, standard- and optional lubrication adapters see page 84.

1.5.15 Dimensions of the WE rail

1.5.15.1 Dimensions WER_R

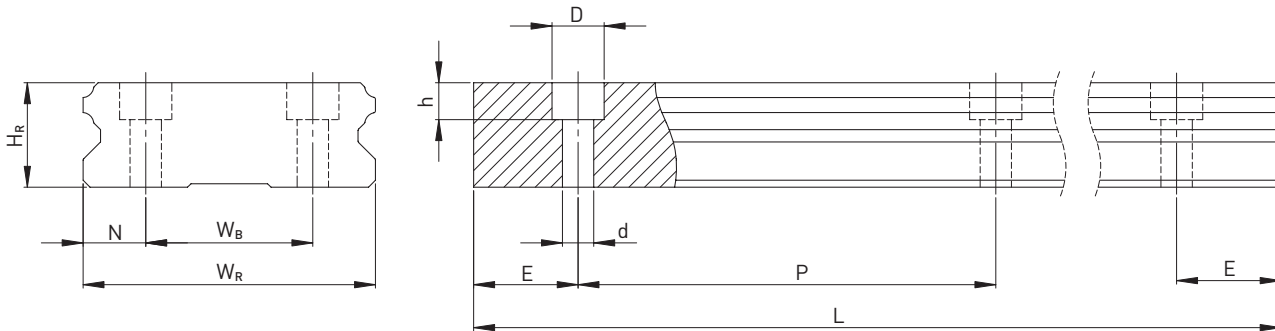

Table 1.74 Dimensions of the rail WER_R

Series Size	Screws for rail [mm]	Dimensions of the rail [mm]							Max. length [mm]	$E_{1/2}$ min [mm]	$E_{1/2}$ max [mm]	Mass [kg/m]
		W_R	W_B	H_R	D	h	d	P				
WER17R	M4 × 12	33	18	9,3	7,5	5,3	4,5	40,0	4000	6	34	2,20
WER21R	M4 × 12	37	22	11,0	7,5	5,3	4,5	50,0	4000	6	44	3,00
WER27R	M4 × 16	42	24	15,0	7,5	5,3	4,5	60,0	4000	6	54	4,70
WER35R	M6 × 20	69	40	19,0	11,0	9,0	7,0	80,0	4000	8	72	9,70

Note:

1. The tolerance for E is +0,5 to -1 mm for standard, for joint connections 0 to -0.3 mm
2. If no information is provided on the $E_{1/2}$ dimensions, the maximum number of fixing holes is determined taking into account $E_{1/2}$ min
3. The rails are shortened to the desired length. If no information on the $E_{1/2}$ dimensions is provided, then the rails are manufactured symmetrically.

1.5.15.2 Calculation of the length of rails

HIWIN offers customer-specific lengths. To ensure that the ends of the rails for nonstandard lengths are stable, value E must not exceed half the distance between the fixing holes (P). In addition, value $E_{1/2}$ must not be less than $E_{1/2}$ min and must not exceed $E_{1/2}$ max to prevent breakage of the fixing hole.

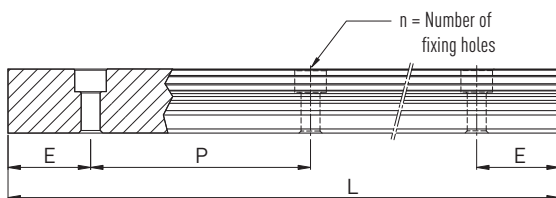

$$L = (n-1) \times P + 2 \times E$$

- L: Total rail length [mm]
- n: Number of fixing holes
- P: Distance between two fixing holes [mm]
- E: Distance from the center of the last fixing hole to the end of the rail [mm]

Linear Guideways

WE series

1.5.15.3 Tightening torques for fixing screws

Insufficient tightening of the fixing screws will highly detract from the accuracy of the linear guideway. The following tightening torques are recommended for the respective screw sizes.

Table 1.76 Tightening torques for fixing screws to ISO 4762-12.9

Series/Size	Screw size	Torque [Nm]	Series/Size	Screw size	Torque [Nm]
WE_17	M4	4	WE_27	M4	4
WE_21	M4	4	WE_35	M6	13

1.5.15.4 Cover cap for rail fixing holes

The cover caps are used to keep the fixing holes free from chips and dirt. The standard plastic bolt caps are enclosed to each rail. Optional caps have to be ordered extra.

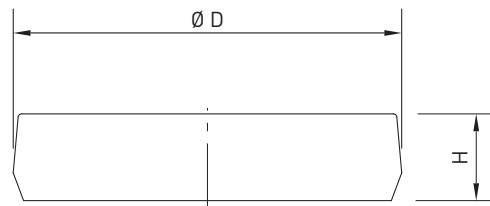

Table 1.77 Cover cap for rail fixing holes

Rail	Screw	Article number			Ø D [mm]	Height H [mm]
		Plastic	Brass	Steel		
WER17R	M4	C4	C4-M	—	7,5	1,1
WER21R	M4	C4	C4-M	—	7,5	1,1
WER27R	M4	C4	C4-M	—	7,5	1,1
WER35R	M6	C6	C6-M	C6-ST	11,0	2,5

1.6 Linear Guideway Series MG

1.6.1 Special characteristics of the linear guideway series MGN

- Tiny and light weight, suitable for miniature equipment.
- All materials for block and rail are in special grade of stainless steel including steel ball and ball retainer for anti-corrosion purpose.
- Gothic arch contact design can sustain the load from all directions and offer high rigidity and high accuracy.
- Steel balls will be held by miniature retainer to avoid the balls from falling out even when the blocks are removed from the rail installation.
- Interchangeable types are available in certain precision grades.

1.6.2 Construction of the MGN series

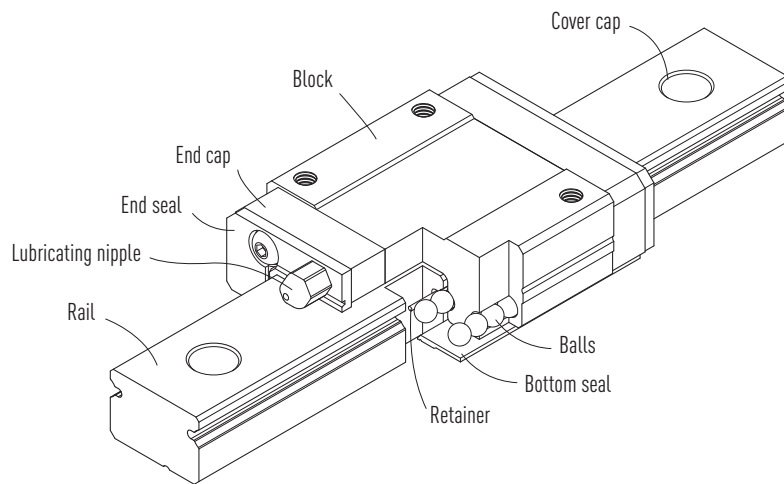

Fig. Construction of the MGN series

- Rolling circulation system: Block, rail, end cap and retainer.
- Lubrication system: The grease nipple is available for MGN15, grease gun can be used for lubricating.
- Dust protection system: End seal, bottom seal (optional size 12,15), cover cap (size 12,15).

Linear Guideways

MG series

1.6.3 Special characteristics of the linear guideway series MGW

The design feature of wide type miniature guideway-MGW:

- The design of enlarged width has increased the capacity of moment load.
- Gothic arch contact design has high rigidity characteristic in all directions.
- Steel balls will be held by miniature retainer to avoid the balls from falling out even when the block are removed from the rail installation.
- All metallic components are made of stainless steel for anti-corrosion purpose.

1.6.4 Construction of the MGW series

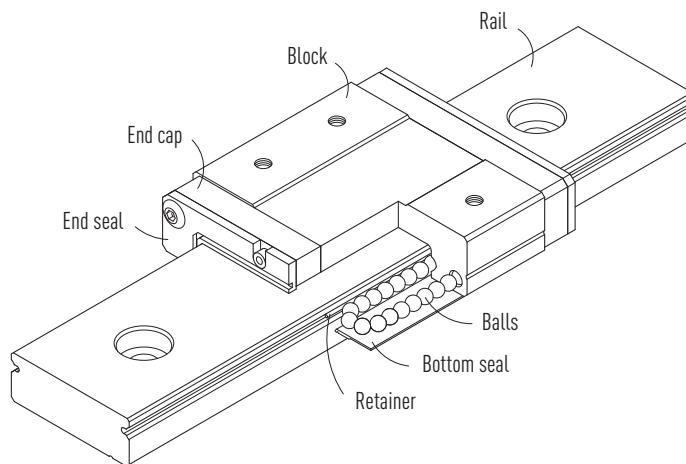

Fig. Construction of the MGW series

- Rolling circulation system: Block, rail, end cap and retainer
- Lubrication system: The grease nipple is available for MGW15, grease gun can be used for lubricating.
- Dust protection system: End seal, bottom seal (optional size 12,15), cover cap (size 12,15).

1.6.5 Application

MGN/MGW series can be used in many fields, such as semiconductor equipment, PCB assembly equipment, medical equipment, robotics, measuring equipment, office automation equipment, and other miniature sliding machinery.

1.6.6 Article numbers for the MGN/MGW series

Linear guideways are available as either interchangeable or non-interchangeable versions. The dimensions of both models are identical. The interchangeable models are more user friendly, as the block and rail can be replaced freely. However, accuracy is lower than that of the non-interchangeable models.

Due to the strict control of dimensional accuracy, the interchangeable models are a good choice for customers not using pairs of rails on a stage. The article numbers include the dimensions, model, accuracy class and preload class etc.

1.6.6.1 Non-interchangeable models (customized models)

- Item number of the fully installed linear guideway

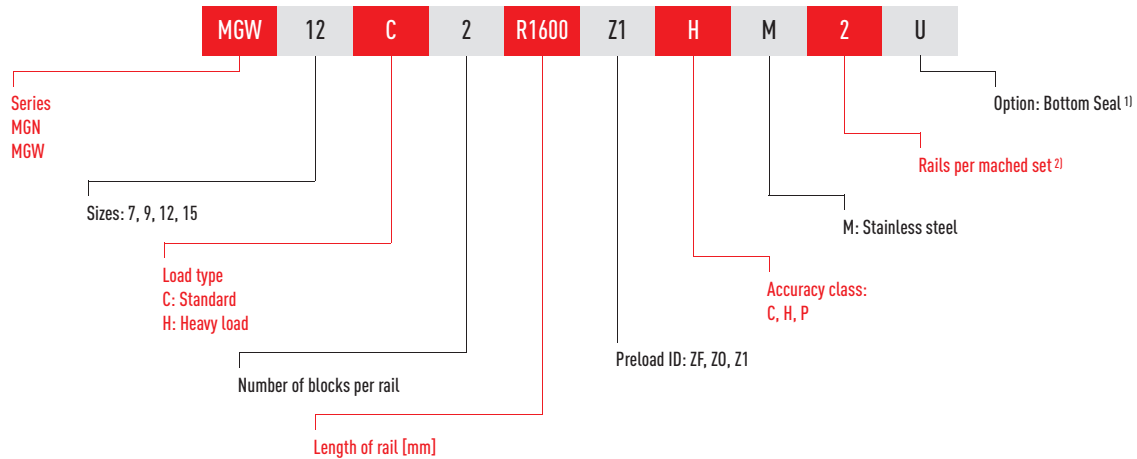

1.6.6.2 Interchangeable models

- Article number of the MG block

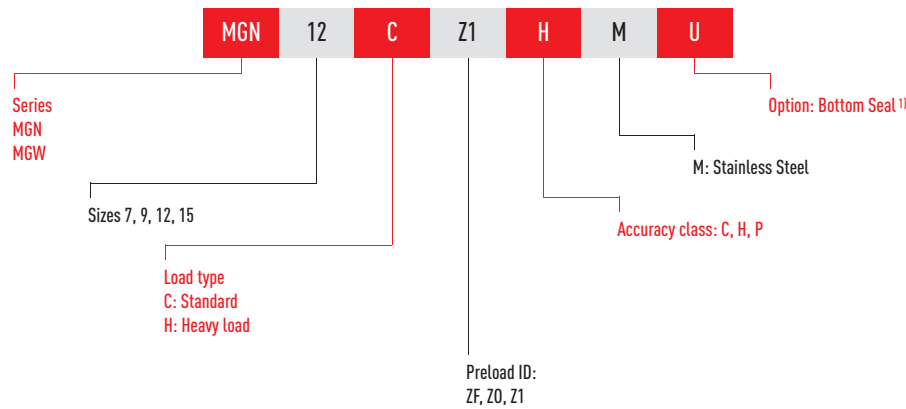

- Article number of the MG rail

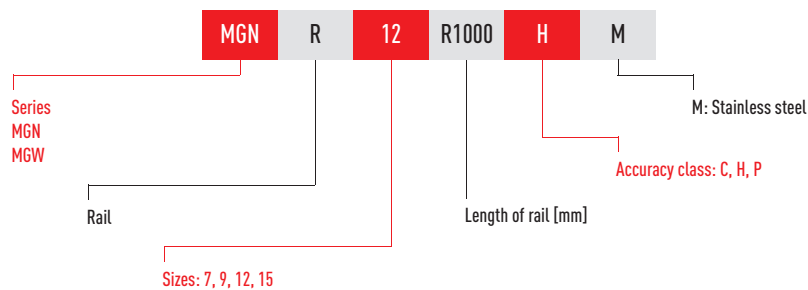

Note:

1. The bottom seal is available for MGN & MGW 12, 15.
2. Figure 2 is also a quantity statement, i.e. a part of the article described above consists of a pair of rails. No figures are provided for individual linear guideways.

Linear Guideways

MG series

1.6.7 Preload

MGN/MGW series provide three preload levels for various applications.

Table 1.78 Preload ID

ID	Preload	Accuracy class
Z0	Light backlash: 4 - 10 μm	C, H
ZA	Free from backlash - very light preload	C - P
ZB	Light Preload: 0 - 0,02 C_{dyn}	C - P

1.6.8 Accuracy classes

The MG series is divided into three classes according to respective accuracy – normal (C), high (H) and precision class (P). The requirements of the machinery in which the linear guideway is used, determines the selection.

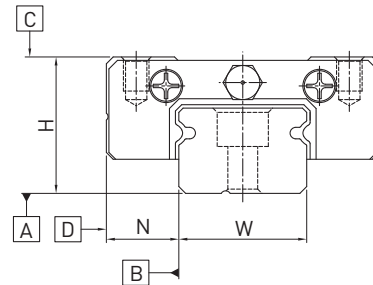

1.6.8.1 Accuracy classes of non-interchangeable types

Parallelism of block surface C with surface A, see table 1.82

Parallelism of block surface D with surface B, see table 1.82

Table 1.79 Tolerances depending on the accuracy class

Series/Size	Accuracy class	Height tolerance of H ¹⁾	Width tolerance of N ¹⁾	Height variance of H ²⁾	Width variance of N ²⁾
MG_7 - MG_15	Normal (C)	$\pm 0,04$	$\pm 0,04$	0,03	0,03
	High (H)	$\pm 0,02$	$\pm 0,025$	0,015	0,02
	Precision (P)	$\pm 0,01$	$\pm 0,015$	0,007	0,01

Unit: mm

1.6.8.2 Accuracy classes of interchangeable types

Parallelism of block surface C with surface A, see table 1.82

Parallelism of block surface D with surface B, see table 1.82

Table 1.80 Tolerances depending on the accuracy class

Series/Size	Accuracy class	Height tolerance of H ¹⁾	Width tolerance of N ¹⁾	Height variance of H ²⁾	Width variance of N ³⁾	Width tolerance of N ⁴⁾
MG_7 - MG_15	Normal (N)	$\pm 0,04$	$\pm 0,04$	0,03	0,03	0,07
	High (H)	$\pm 0,02$	$\pm 0,025$	0,015	0,02	0,04
	Precision (P)	$\pm 0,01$	$\pm 0,015$	0,007	0,01	0,02

Unit: mm

¹⁾ Tolerance data that applies to any block on any rail.

²⁾ Permissible absolute dimensional deviation between several blocks, distributed over one individual rail or a pair of rails.

³⁾ Permissible absolute dimensional deviation between several blocks, distributed over one individual rail.

⁴⁾ Permissible absolute dimensional deviation between several blocks, distributed over a pair of rails.

Table 1.82 Tolerance parallelism between block and rail

Rail length [mm]	Accuracy class			Rail length [mm]	Accuracy class		
	C	H	P		C	H	P
– 50	12	6	2	315 – 400	18	11	6
50 – 80	13	7	3	400 – 500	19	12	6
80 – 125	14	8	3,5	500 – 630	20	13	7
125 – 200	15	9	4	630 – 800	22	14	8
200 – 250	16	10	5	800 – 1000	23	16	9
250 – 315	17	11	5	1000 – 1200	25	18	11

Unit: μm

1.6.9 Dust protection equipment

End seals and standard accessories fixed on both sides of the block can prevent dust from entering the block, so the accuracy and service life of a linear guideway can be maintained. Bottom seals are fixed under the skirt portion of the block to prevent dust from entering. Customers can order bottom seals by adding the mark "+U" followed by the model number. Sizes 12 and 15 provide bottom seals as an option, sizes 7 and 9 do not offer the option due to the space limit of H_1 . If the linear guideway is equipped with a bottom seal, the lateral mounting surface of the rail must not exceed H_1 .

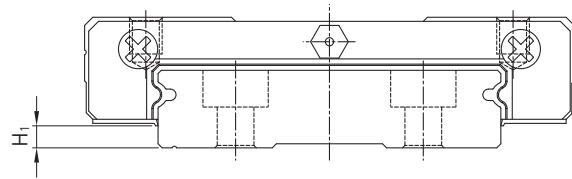

Table 1.84 Space limit H_1

Series/Size	Bottom seal	H_1	Series/Size	Bottom seal	H_1
MGN07	—	—	MGW07	—	—
MGN09	—	—	MGW09	—	—
MGN12	•	2,0	MGW12	•	2,6
MGN15	•	3,0	MGW15	•	2,6

1.6.10 Friction

The table shows the maximum frictional resistance of the end seals of one block. The specified values apply to blocks on uncoated rails. Higher frictional forces occur on coated rails.

Table 1.86 Frictional resistance of the seals

Series/Size	Resistance [N]	Series/Size	Resistance [N]
MGN07	0,1	MGW07	0,2
MGN09	0,1	MGW09	0,2
MGN12	0,2	MGW12	0,3
MGN15	0,2	MGW15	0,3

Linear Guideways

MG series

1.6.11 Shoulder heights and fillets

Improper shoulder heights and fillets of mounting surfaces will cause a deviation in accuracy and the interference with the chamfered part of the rail or block. As long as the recommended shoulder heights and fillets are followed, installation inaccuracies should be eliminated.

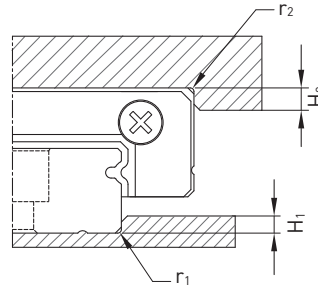

Table 1.87 Shoulder heights and fillets

Series/Size	Max. radius of fillets r_1	Max. radius of fillets r_2	Shoulder height of H_1	Shoulder height of H_2
MGN07	0,2	0,2	1,2	3
MGN09	0,2	0,3	1,7	3
MGN12	0,3	0,4	1,7	4
MGN15	0,5	0,5	2,5	5
MGW07	0,2	0,2	1,7	3
MGW09	0,3	0,3	2,5	3
MGW12	0,4	0,4	3	4
MGW15	0,4	0,8	3	5

Unit: mm

1.6.12 Load ratings and torques

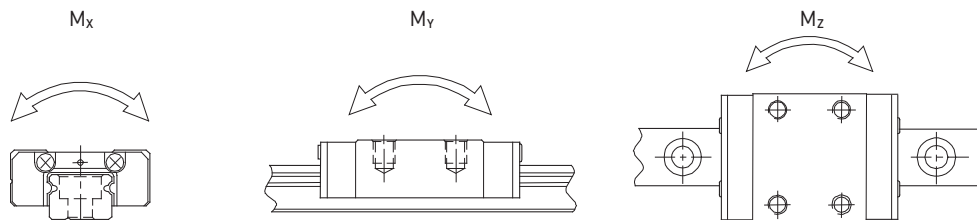

Table 1.88 Load ratings and torques for MG series

Series/Size	Dynamic load C_{dyn} [N]*	Static load C_0 [N]	Dynamic moment [Nm]			Static moment [Nm]		
			M_x	M_y	M_z	M_{0x}	M_{0y}	M_{0z}
MGN07C	980	1240	3	2	2	4,70	2,84	2,84
MGN07H	1370	1960	5	3	3	7,64	4,80	4,80
MGN09C	1860	2550	8	5	5	11,76	7,35	7,35
MGN09H	2550	4020	12	12	12	19,60	18,62	18,62
MGN12C	2840	3920	18	10	10	25,48	13,72	13,72
MGN12H	3720	5880	24	23	23	38,22	36,26	36,26
MGN15C	4610	5590	37	18	18	45,08	21,56	21,56
MGN15H	6370	9110	52	41	41	73,50	57,82	57,82
MGW07C	1370	2060	10	4	4	15,70	7,14	7,14
MGW07H	1770	3140	13	8	8	23,45	15,53	15,53
MGW09C	2750	4120	27	12	12	40,12	18,96	18,96
MGW09H	3430	5890	32	20	20	54,54	34	34
MGW12C	3920	5590	50	19	19	70,34	27,80	27,80
MGW12H	5100	8240	64	36	36	102,70	57,37	57,37
MGW15C	6770	9220	149	42	42	199,34	56,66	56,66
MGW15H	8930	13380	196	80	80	299,01	122,60	122,60

* Dynamic load rating for 50,000 m travel path

1.6.13 Rigidity

Rigidity is dependent on the preload. Using formula 1.1, it is possible to determine the deformation in relation to the rigidity.

$$\delta = \frac{P}{k}$$

δ: deformation [μm]

P: Operating load [N]

k: Rigidity value [N/μm]

Table 1.89 Radial rigidity series MGN

Load Class	Series Size	Preload	
		Z0	Z1
Medium Load	MGN07C	26	33
	MGN09C	37	48
	MGN12C	44	56
	MGN15C	57	74
Heavy Load	MGN07H	39	51
	MGN09H	56	73
	MGN12H	63	81
	MGN15H	87	113

Unit: N/μm

Table 1.90 Radial rigidity series MGW

Load Class	Series Size	Preload	
		Z0	Z1
Medium Load	MGW07C	38	49
	MGW09C	55	71
	MGW12C	63	81
	MGW15C	78	101
Heavy Load	MGW07H	54	70
	MGW09H	74	95
	MGW12H	89	114
	MGW15H	113	145

Unit: N/μm

Linear Guideways

MG series

1.6.14 Dimensions of the MG block

1.6.14.1 MGN-C / MGN-H

MGN7, MGN9, MGN12

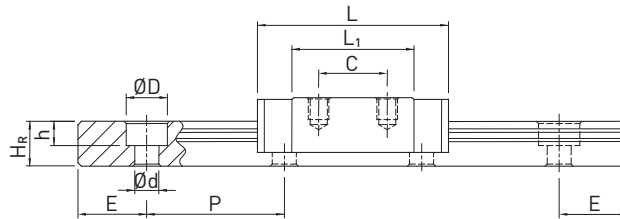
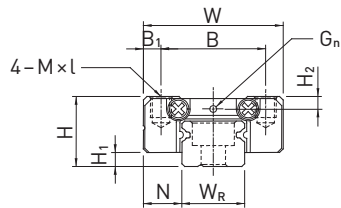

MGN15

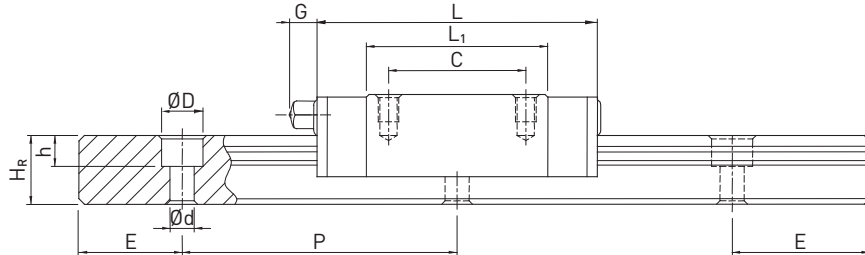
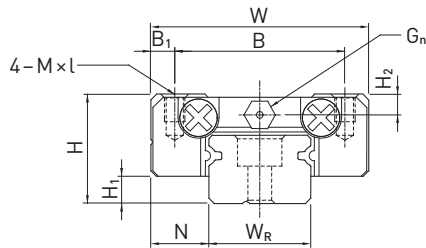

Table 1.91 Dimensions of the block

Series Size	Installation dimensions [mm]			Dimensions of the block [mm]										Load Ratings [N]		Mass [kg]
	H	H ₁	N	W	B	B ₁	C	L ₁	L	G	G _n	M × l	H ₂	C _{dyn}	C ₀	
MGN07C	8	1,5	5,0	17	12	2,5	8	13,5	22,5	0	∅ 1,2	M2 × 2,5	1,5	980	1240	0,01
MGN07H							13	21,8	30,8					1370	1960	0,02
MGN09C	10	2	5,5	20	15	2,5	10	18,9	28,9	0	∅ 1,4	M3 × 3	1,8	1860	2550	0,02
MGN09H							16	29,9	39,9					2550	4020	0,03
MGN12C	13	3	7,5	27	20	3,5	15	21,7	34,7	0	∅ 2	M3 × 3,5	2,5	2840	3920	0,03
MGN12H							20	32,4	45,4					3720	5880	0,05
MGN15C	16	4	8,5	32	25	3,5	20	26,7	42,1	4,5	M3	M3 × 4	3	4610	5590	0,06
MGN15H							25	43,4	58,8					6370	9110	0,09

Dimensions of the rail see page 68, standard- and optional lubrication adapters see page 84.

1.6.14.2 MGW-C / MGW-H

MGW7, MGW9, MGW12

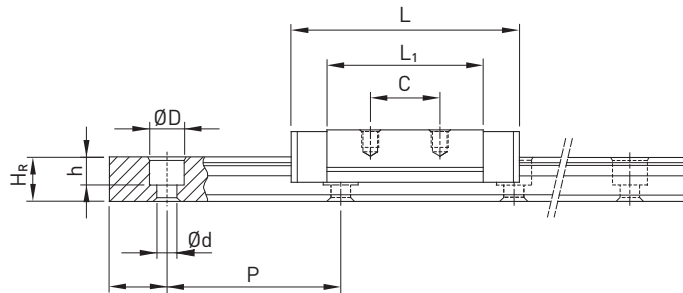
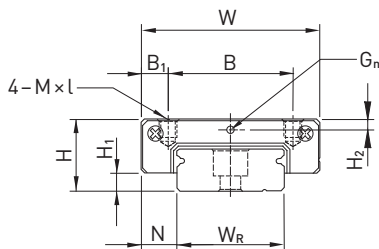

MGW15

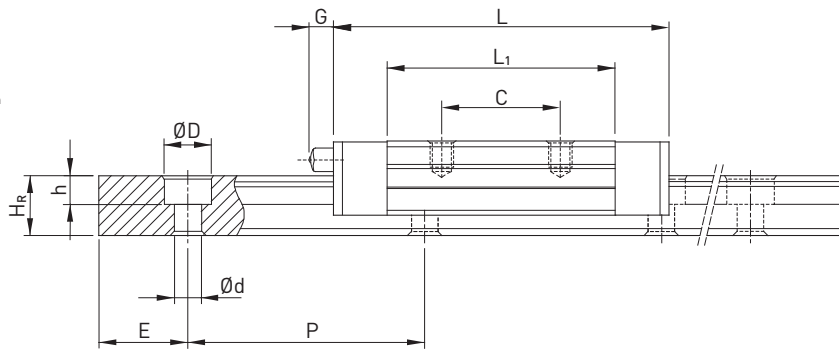
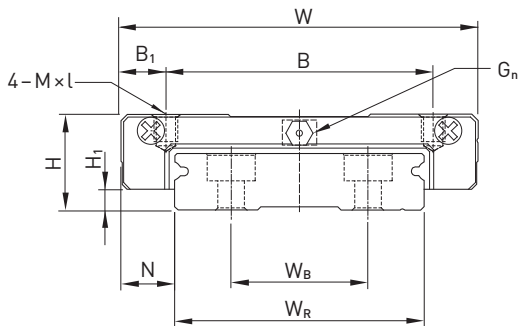

Table 1.92 Dimensions of the block

Series Size	Installation dimensions [mm]			Dimensions of the block [mm]										Load Ratings [N]		Mass [kg]
	H	H ₁	N	W	B	B ₁	C	L ₁	L	G	G _n	M × l	H ₂	C _{dyn}	C ₀	
MGW07C	9	1,9	5,5	25	19	3	10	21	31,2	0	Ø1,2	M3 × 3	1,85	1370	2060	0,02
MGW07H							19	30,8	41					1770	3140	0,03
MGW09C	12	2,9	6,0	30	21	4,5	12	27,5	39,3	0	Ø1,4	M3 × 3	2,4	2750	4120	0,04
MGW09H					23	3,5	24	38,5	50,7					3430	5890	0,06
MGW12C	14	3,4	8,0	40	28	6	15	31,3	46,1	0	Ø2	M3 × 3,6	2,8	3920	5590	0,07
MGW12H							28	45,6	60,4					5100	8240	0,10
MGW15C	16	3,4	9,0	60	45	7,5	20	38	54,8	5,2	M3	M4 × 4,2	3,2	6770	9220	0,14
MGW15H							35	57	73,8					8930	13380	0,22

Dimensions of the rail see page 68, standard- and optional lubrication adapters see page 84.

Linear Guideways

MG series

1.6.15 Dimensions of the MG rail

1.6.15.1 Dimensions MGN_R

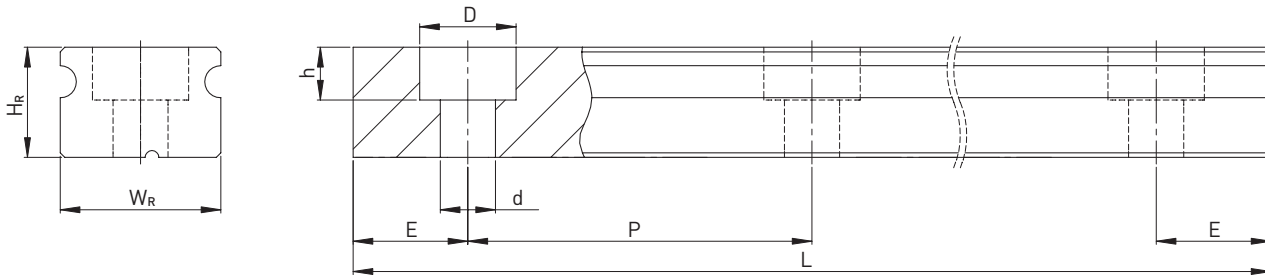

Table 1.93 Dimensions of the rail MGN_R

Series Size	Screws for rail [mm]	Dimensions of the rail [mm]						Max. length [mm]	Max. length $E_1 = E_2$	$E_{1/2}$ min [mm]	$E_{1/2}$ max [mm]	Mass [kg/m]
		W_R	H_R	D	h	d	P					
MGNR07R	M2 × 6	7	4,8	4,2	2,3	2,4	15,0	600	585	5	10	0,22
MGNR09R	M3 × 8	9	6,5	6,0	3,5	3,5	20,0	1200	1180	5	15	0,38
MGNR12R	M3 × 8	12	8,0	6,0	4,5	3,5	25,0	2000	1975	5	20	0,65
MGNR15R	M3 × 10	15	10,0	6,0	4,5	3,5	40,0	2000	1960	6	34	1,06

1.6.15.2 Dimensions MGW_R

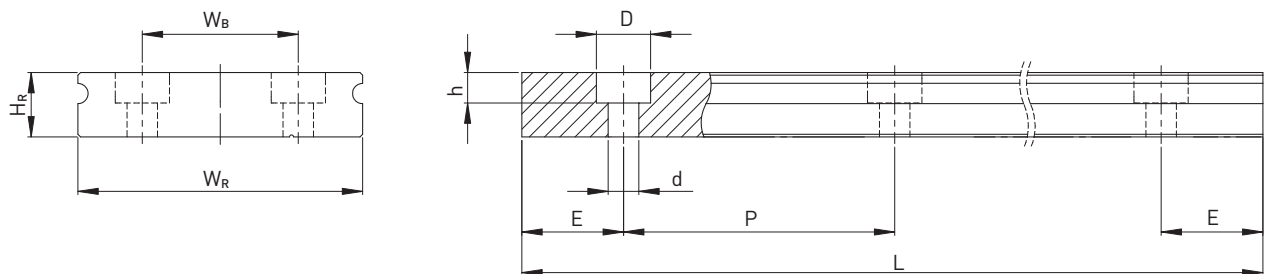

Table 1.94 Dimensions of the rail MGW_R

Series Size	Screws for rail [mm]	Dimensions of the rail [mm]							Max. length [mm]	Max. length $E_1 = E_2$ [mm]	$E_{1/2}$ min [mm]	$E_{1/2}$ max [mm]	Mass [kg/m]
		W_R	H_R	W_B	D	h	d	P					
MGWR07R	M3 × 6	14	5,2	—	6,0	3,2	3,5	30	600	570	6	24	0,51
MGWR09R	M3 × 8	18	7,0	—	6,0	4,5	3,5	30	1200	1170	6	24	0,91
MGWR12R	M4 × 8	24	8,5	—	8,0	4,5	4,5	40	2000	1960	8	32	1,49
MGWR15R	M4 × 10	42	9,5	23	8,0	4,5	4,5	40	2000	1960	8	32	2,86

Note:

- The tolerance for E is +0,5 to -1,0 mm for standard, for joint connections 0 to -0.3 mm
- If no information is provided on the $E_{1/2}$ dimensions, the maximum number of fixing holes is determined taking into account $E_{1/2}$ min

1.6.15.3 Calculation of the length of rails

HIWIN offers customer-specific lengths. To ensure that the ends of the rails for nonstandard lengths are stable, value E must not exceed half the distance between the fixing holes (P). In addition, value $E_{1/2}$ must not be less than $E_{1/2}$ min and must not exceed $E_{1/2}$ max to prevent breakage of the fixing hole.

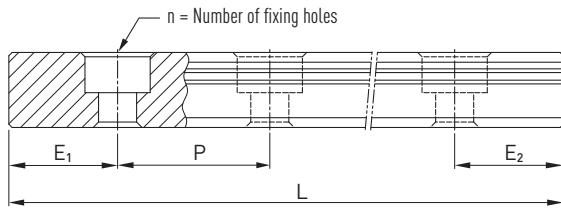

$$L = (n-1) \cdot P + E_1 + E_2$$

- L: Total rail length [mm]
- n: Number of fixing holes
- P: Distance between two fixing holes [mm]
- $E_{1/2}$: Distance from the center of the last fixing hole to the end of the rail [mm]

1.6.15.4 Tightening torques for fixing screws

Insufficient tightening of the fixing screws will highly detract from the accuracy of the linear guideway; the following tightening torques are recommended for the respective screw sizes.

Table 1.96 Tightening torques for fixing screws to ISO 4762-12.9

Series/Size	Screw size	Torque [Nm]	Series/Size	Screw size	Torque [Nm]
MGN7	M2 × 6	0,6	MGW7	M3 × 6	2
MGN9	M3 × 8	2	MGW9	M3 × 8	2
MGN12	M3 × 8	2	MGW12	M4 × 8	4
MGN15	M3 × 10	2	MGW15	M4 × 10	4

1.6.15.5 Cover cap for rail fixing holes

The cover caps are used to keep the fixing holes free from chips and dirt. The standard plastic bolt caps are enclosed to each rail. Optional caps have to be ordered extra.

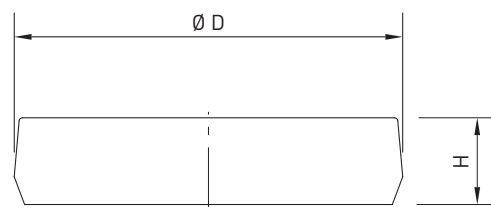

Table 1.97 Cover cap for rail fixing holes

Rail	Screw	Article number	Ø D [mm]	Height H [mm]
		Plastic		
MGNR09R	M3	C3 ¹⁾	6,0	1,1
MGNR12R	M3	C3	6,0	1,1
MGNR15R	M3	C3	6,0	1,1
MGWR09R	M3	C3	6,0	1,1
MGWR12R	M4	C4A	8,0	1,1
MGWR15R	M4	C4A	8,0	1,1

Linear Guideways

RG series

1.7 Linear Guideway Series RG

1.7.1 Special characteristics of the linear guideway series RG

The new RG series from Hiwin features a roller as the rolling element instead of steel balls. The roller series offers super high rigidity and very high load capacities. The RG series is designed with a 45-degree contact angle. Elastic deformation of the linear contact surface, during load, is greatly reduced thereby offering greater rigidity and higher load capacities in all 4 load directions. The RG series linear guideway offers high performance for high-precision manufacturing and achieving longer service life.

1.7.2 Construction of the RG series

- 4-row recirculation roller bearing
- 45° contact angle
- The roller retainers prevent the rollers from falling out when the carriage is removed
- Different sealing variants, depending on application area
- Six connection options for grease nipples or grease adapters

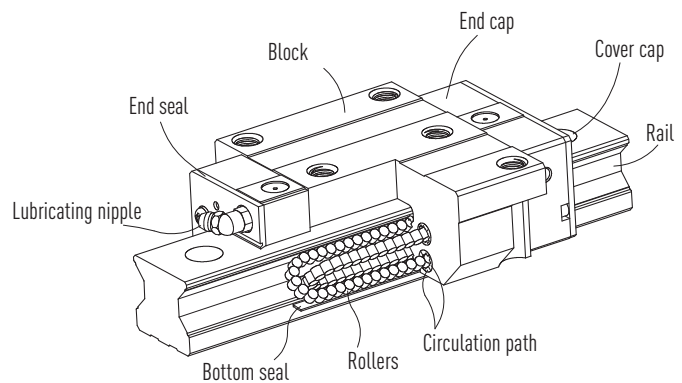

Fig. Construction of the RG series

1.7.3 Advantages

- Free of play
- Replaceable
- High precision
- Very high load capacity
- Low displacement force also with high preload

1.7.4 Article numbers for the RG series

Linear guideways series RG are available as either interchangeable or non-interchangeable versions. The dimensions of both models are identical. The interchangeable models are more user friendly, as the block and rail can be replaced freely. However, accuracy is lower than that of the non-interchangeable models. Due to the strict control of dimensional accuracy, the interchangeable models are a good choice for customers not using pairs of rails on a stage. The article numbers include the dimensions, model, accuracy class and preload class etc.

1.7.4.1 Non-interchangeable models (customized models)

○ Item number of the fully installed linear guideway

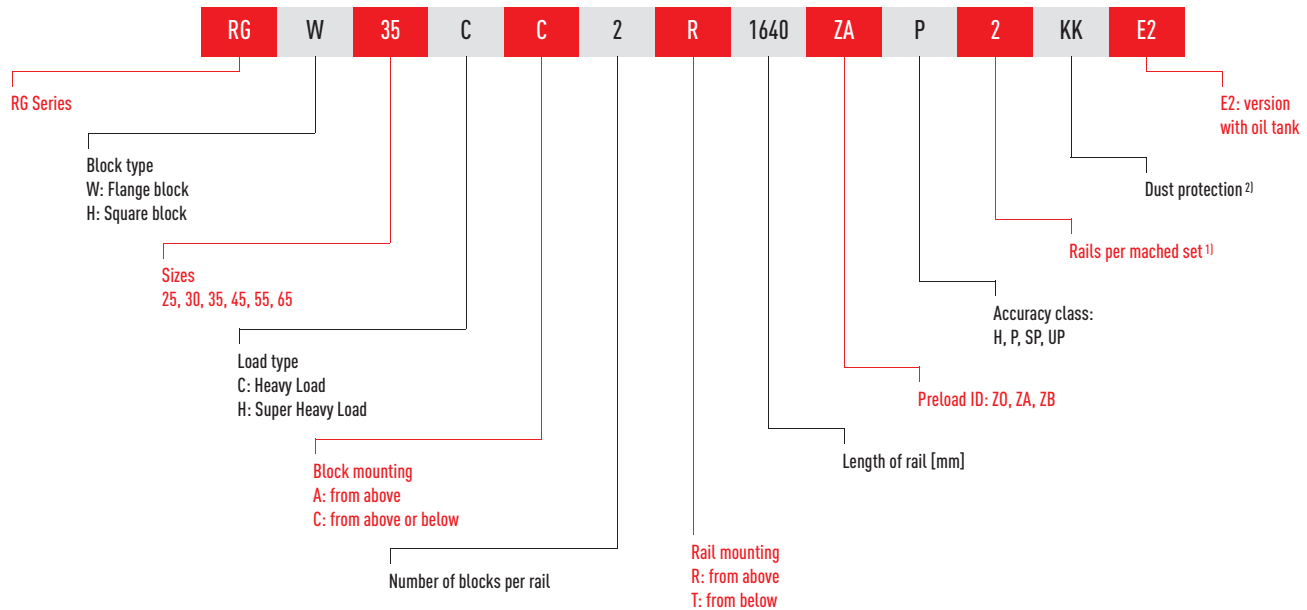

1.7.4.2 Interchangeable models

○ Article number of the RG block

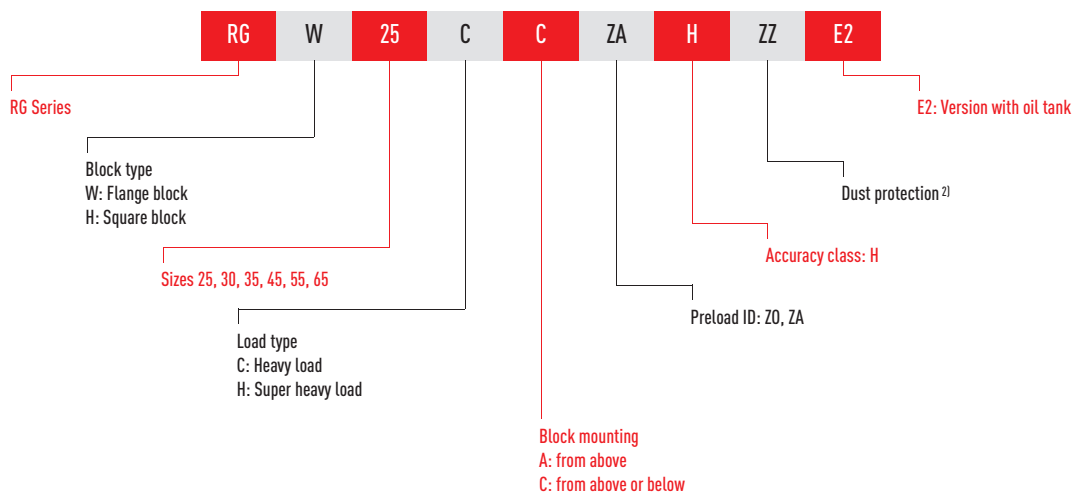

○ Article number of the RG rail

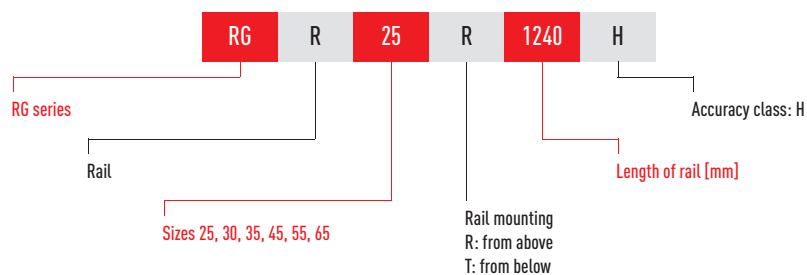

Note:

1) Figure 2 is also a quantity statement, i.e. a part of the article described above consists of a pair of rails. No figures are provided for individual linear guideways.

2) No information is provided for the standard version for dust protection (end seal and bottom seal)

ZZ: End seal, bottom seal and scraper

KK: Double seals, bottom seal and scraper

DD: Double seals and bottom seal

SW: Special seal for applications in very heavily contaminated environment

Linear Guideways

RG series

1.7.5 Block types

HIWIN offers square blocks and flange blocks for its linear guideways. The low assembly height and larger installation surface makes flange blocks more suitable for heavy loads.

Table 1.98 Block types

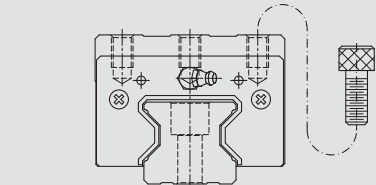
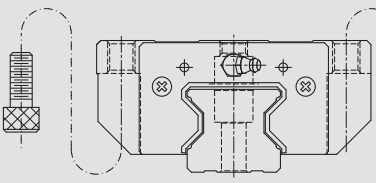
Type	Series Size	Construction	Height [mm]	Rail length [mm]	Typical application
Square	RGH-CA RGH-HA		40 - 90	100 - 4.000	<ul style="list-style-type: none"> ○ Automation Systems ○ Transportation equipment ○ CNC machining centers ○ Heavy duty cutting machines ○ CNC grinding machines ○ Injection molding machines ○ Plano millers ○ Devices requiring high rigidity ○ Devices requiring high load capacity ○ Electric discharge machines
			36 - 90		
Flange	RGW-CC RGW-HC				

1.7.6 Preload

1.7.6.1 Definition

A preload can be applied to any rails version. For this purpose, oversized balls are used. Normally a linear guideway has a negative clearance between the path and the ball bearings, to increase rigidity and precision. The linear guideway of the RG-series offers three standard preload classes.

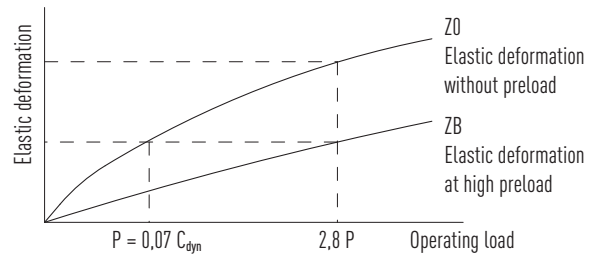

1.7.6.2 Preload ID

Table 1.99 Preload ID

ID	Preload		Application
Z0	Light preload	0,02 C - 0,04 C _{dyn}	Certain load direction, low impact, low precision required
ZA	Medium preload	0,07 C - 0,09 C _{dyn}	High rigidity required, high precision required
ZB	Heavy preload	0,12 C - 0,14 C _{dyn}	Super high rigidity required, with vibration and impact

Note:

Preload classes for interchangeable versions Z0 and ZA. For non-interchangeable versions: Z0, ZA, ZB.

The figure shows the relationship between the rigidity, friction and nominal life. A preload not larger than ZA would be recommended for smaller model sizes to avoid over-preload affecting the life of the guideway.

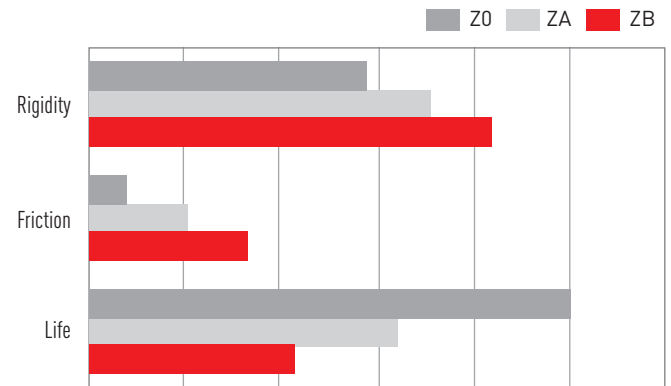

1.7.7 Accuracy classes

The RG series is divided into four classes according to respective accuracy – high (H), precision class (P), super precision class (SP) and ultra precision class (UP). The requirements of the machinery in which the linear guideway is used, determine the selection.

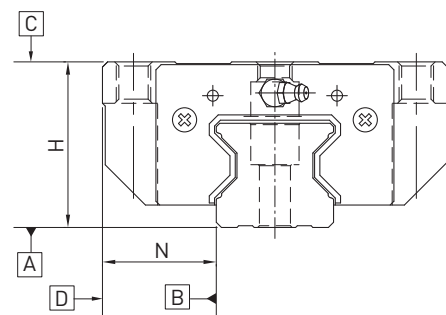

1.7.7.1 Accuracy classes of non-interchangeable types

Parallelism of block surface C with surface A, see table 1.102

Parallelism of block surface D with surface B, see table 1.102

Table 1.100 Tolerances depending on the accuracy class

Series/Size	Accuracy class	Height tolerance of H ¹⁾	Width tolerance of N ¹⁾	Height variance of H ²⁾	Width variance of N ²⁾
RG_25, 30, 35	High (H)	± 0,04	± 0,04	0,015	0,015
	Precision (P)	0 - 0,04	0 - 0,04	0,007	0,007
	Super precision (SP)	0 - 0,02	0 - 0,02	0,005	0,005
	Ultra precision (UP)	0 - 0,01	0 - 0,01	0,003	0,003
RG_45, 55	High (H)	± 0,05	± 0,05	0,015	0,02
	Precision (P)	0 - 0,05	0 - 0,05	0,007	0,01
	Super precision (SP)	0 - 0,03	0 - 0,03	0,005	0,007
	Ultra precision (UP)	0 - 0,02	0 - 0,02	0,003	0,005
RG_65	High (H)	± 0,07	± 0,07	0,02	0,025
	Precision (P)	0 - 0,07	0 - 0,07	0,01	0,015
	Super precision (SP)	0 - 0,05	0 - 0,05	0,007	0,01
	Ultra precision (UP)	0 - 0,03	0 - 0,03	0,005	0,007

Unit: mm

¹⁾ Tolerance data that applies to any rail with any block

²⁾ Permissible absolute dimensional deviation between several blocks distributed over one individual rail or located on a pair of rails

Linear Guideways

RG series

1.7.7.2 Accuracy classes of interchangeable types

Parallelism of block surface C with surface A, see table 1.102

Parallelism of block surface D with surface B, see table 1.102

Table 1.101 Tolerances depending on the accuracy class

Series/Size	Accuracy class	Height tolerance of H ¹⁾	Width tolerance of N ¹⁾	Height variance of H ²⁾	Width variance of N ²⁾
RG_25, 30, 35	High (H)	± 0,04	± 0,04	0,015	0,015
	Precision (P)	± 0,02	± 0,02	0,007	0,007
RG_45, 55	High (H)	± 0,05	± 0,05	0,015	0,02
	Precision (P)	± 0,025	± 0,025	0,007	0,01
RG_65	High (H)	± 0,07	± 0,07	0,02	0,025
	Precision (P)	± 0,035	± 0,035	0,01	0,015

Unit: mm

¹⁾ Tolerance data that applies to any block on any rail

²⁾ Permissible absolute dimensional deviation between several blocks, distributed over one individual rail or located on a pair of rails

Table 1.102 Tolerance parallelism between block and rail

Rail length [mm]	Accuracy class			
	H	P	SP	UP
– 100	7	3	2	2
100 – 200	9	4	2	2
200 – 300	10	5	3	2
300 – 500	12	6	3	2
500 – 700	13	7	4	2
700 – 900	15	8	5	3
900 – 1100	16	9	6	3
1100 – 1500	18	11	7	4
1500 – 1900	20	13	8	4
1900 – 2500	22	15	10	5
2500 – 3100	25	18	11	6
3100 – 3600	27	20	14	7
3600 – 4000	28	21	15	7

Unit: µm

1.7.8 Dust protection

A variety of sealing systems are available for the HIWIN sliding carriage. You will find an overview of these on page 87. In the following table, the overall lengths of the sliding carriages with different sealing systems are listed. The corresponding sealing systems are available for these design sizes.

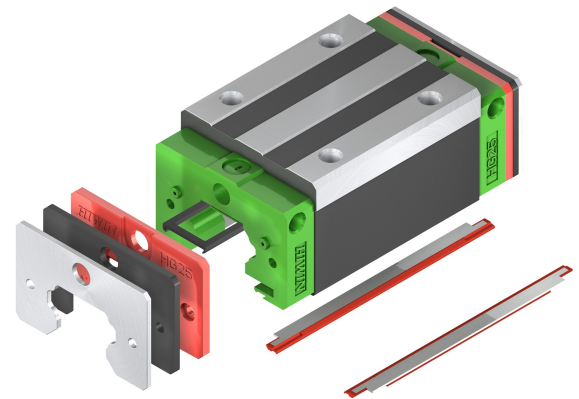
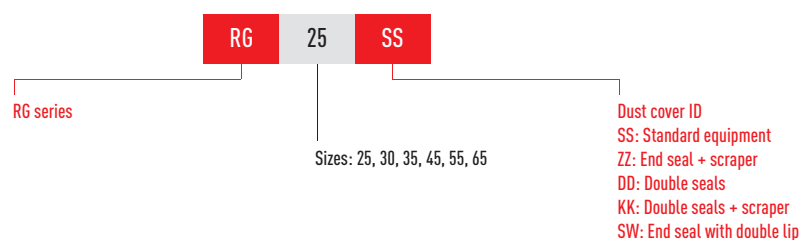

Table 1.103 The overall length of the sliding carriage with different sealing systems

Series Size	Gesamtlänge L					
	SS	DD	ZZ	KK	SW	ZWX
HG_25C	97,9	102,3	99,9	104,3	—	—
HG_25H	114,4	118,8	116,4	120,8	—	—
HG_30C	109,8	114,6	112,8	117,6	—	—
HG_30H	131,8	136,6	134,8	139,6	—	—
HG_35C	124,0	129,0	127,0	132,0	—	—
HG_35H	151,5	156,5	154,5	159,5	—	—
HG_45C	153,2	160,4	156,2	163,4	154,0	160,2
HG_45H	187,0	194,2	190,0	197,2	187,8	194,0
HG_55H	183,7	190,9	186,7	193,9	184,5	191,7
HG_65C	232,0	239,2	235,0	242,2	232,8	240,0
HG_65H	232,0	240,8	235,0	243,8	231,2	238,4
RG_65H	295,0	303,8	298,0	306,8	294,2	301,4

1.7.8.1 Designation of the seal sets

The seal sets are always shipped complete with the installation materials and include the supplemental parts for the standard seal.



1.7.9 Friction

The table shows the maximum frictional resistance of the single endseal. Depending on the seal arrangement (SS, ZZ, DD, KK), the value has to be multiplied accordingly. The specified values apply to blocks on uncoated rails. Higher frictional forces occur on coated rails.

Table 1.105 Frictional resistance of the single-lip seals

Series/Size	Resistance [N]	Series/Size	Resistance [N]
RG_25	2,8	RG_45	4,2
RG_30	3,3	RG_55	5,1
RG_35	3,5	RG_65	6,7

Linear Guideways

RG series

1.7.10 The accuracy tolerance of mounting surface

As long as the accuracy requirements of the mounting surfaces shown in the following tables are met, the high accuracy, high rigidity and long life of the RG series linear guideway will be maintained without any difficulty.

- The parallelism tolerance of reference surface (P)

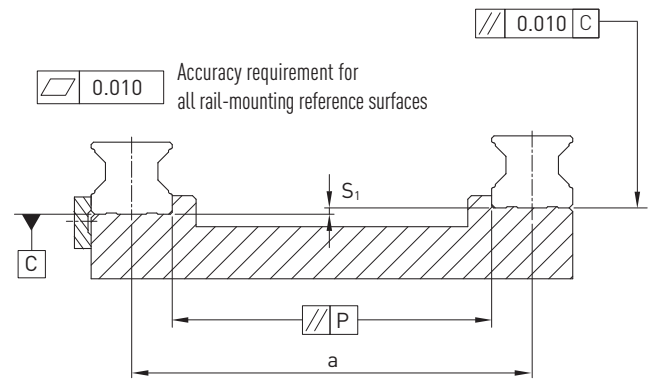

- The parallelism tolerance of reference surface (P)

Table 1.106 Maximum tolerances for the parallel alignment (P)

Series/Size	Load class		
	Z0	ZA	ZB
RG_25	9	7	5
RG_30	11	8	6
RG_35	14	10	7
RG_45	17	13	9
RG_55	21	14	11
RG_65	27	18	14

Unit: μm

- The accuracy tolerance of reference surface height (S_1)

$$S_1 = a \times K$$

S_1 : Max. tolerance of height
 a : Distance between paired rails
 K : Coefficient of tolerance of height

Table 1.107 Coefficient of tolerance of height

Series/Size	Load class		
	Z0	ZA	ZB
RG_25 - RG_65	$2,2 \times 10^{-4}$	$1,7 \times 10^{-4}$	$1,2 \times 10^{-4}$

The accuracy tolerance of block-mounting surface

- The tolerance of the height of reference surface when two or more pieces are used in parallel (S_2)

$$S_2 = b \times 4.2 \times 10^{-5}$$

S_2 : Max. tolerance of height
b: Distance between paired blocks

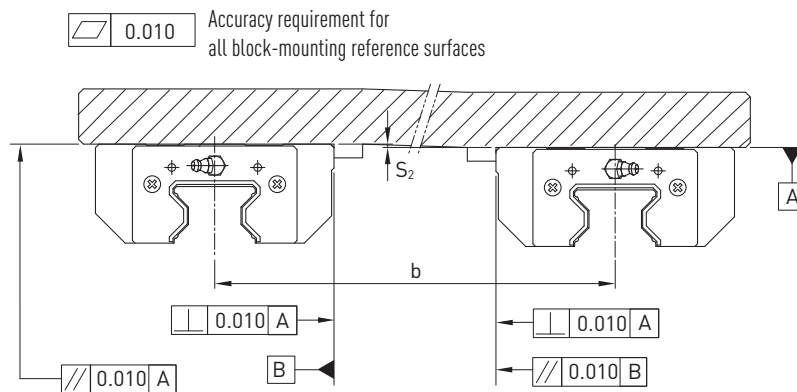

- The tolerance of the height of reference surface when two or more pieces are used in parallel (S_3)

$$S_3 = c \times 4.2 \times 10^{-5}$$

S_3 : Max. tolerance of height
c: Distance between paired blocks

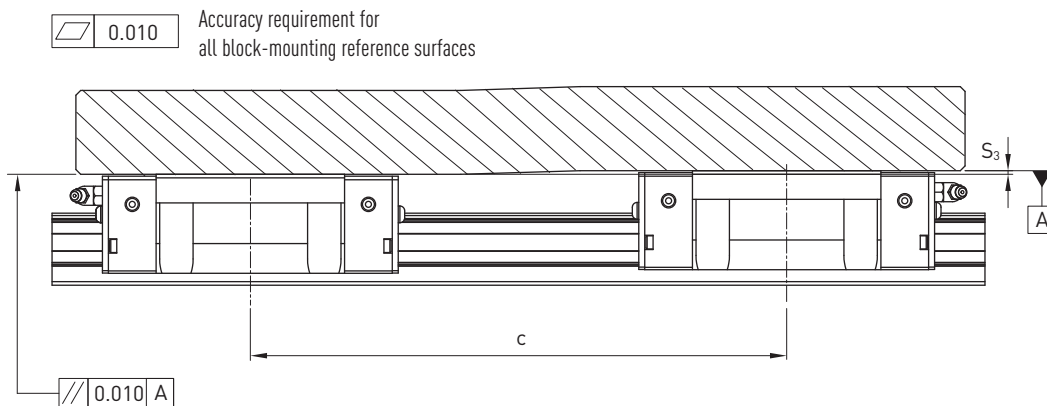

Linear Guideways

RG series

1.7.11 Shoulder heights and fillets

Improper shoulder heights and fillets of mounting surfaces will cause a deviation in accuracy and the interference with the chamfered part of the rail or block. As long as the recommended shoulder heights and fillets are followed, installation inaccuracies should be eliminated.

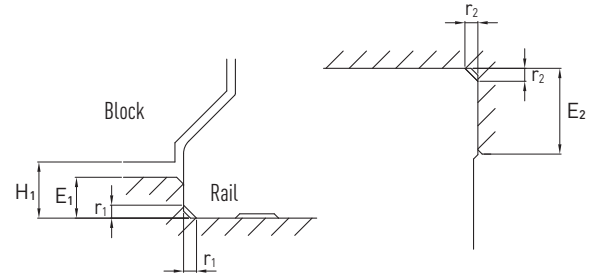

Table 1.108 Shoulder heights and fillets

Series/Size	Max. radius of fillets r_1	Max. radius of fillets r_2	Shoulder height of the rail E_1	Shoulder height of the block E_2	Clearance under block H_1
RG_25	1,0	1,0	5,0	5,0	5,5
RG_30	1,0	1,0	5,0	5,0	6,0
RG_35	1,0	1,0	6,0	6,0	6,5
RG_45	1,0	1,0	7,0	8,0	8,0
RG_55	1,5	1,5	9,0	10,0	10,0
RG_65	1,5	1,5	10,0	10,0	12,0

Unit: mm

1.7.12 Load ratings and torques

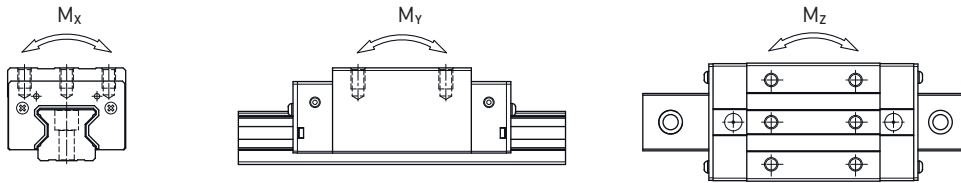

Table 1.109 Load ratings and torques for RG series

Series/Size	Dynamic load C_{dyn} [N]*	Static load C_0 [N]	Dynamic moment [Nm]			Static moment [Nm]		
			M_x	M_y	M_z	M_{0x}	M_{0y}	M_{0z}
RG_25C	27700	57100	367	293	293	758	605	605
RG_25H	33900	73400	450	457	457	975	991	991
RG_30C	39100	82100	688	504	504	1445	1060	1060
RG_30H	48100	105000	845	784	784	1846	1712	1712
RG_35C	57900	105200	1194	792	792	2170	1440	1440
RG_35H	73100	142000	1508	1338	1338	2930	2600	2600
RG_45C	92600	178800	2340	1579	1579	4520	3050	3050
RG_45H	116000	230900	3180	2748	2748	6330	5470	5470
RG_55C	130500	252000	4148	2796	2796	8010	5400	5400
RG_55H	167800	348000	5376	4942	4942	11150	10250	10250
RG_65C	213000	411600	8383	5997	5997	16200	11590	11590
RG_65H	275300	572700	10839	10657	10657	22550	22170	22170

* Dynamic load rating for 100.000 m travel path

1.7.13 Rigidity

Rigidity is dependent on the preload. Using formula 1.1, it is possible to determine the deformation in relation to the rigidity.

$$\delta = \frac{P}{k}$$

δ : deformation [μm]
 P: Operating load [N]
 k: Rigidity value [N/ μm]

Formula 1.1

Table 1.110 **Radial rigidity series RG**

Load class	Series Size	Preload		
		Z0	ZA	ZB
Heavy load	RG_25C	682	717	740
	RG_30C	809	849	876
	RG_35C	954	1002	1035
	RG_45C	1433	1505	1554
	RG_55C	1515	1591	1643
	RG_65C	2120	2227	2300
Super heavy load	RG_25H	873	917	947
	RG_30H	1083	1136	1173
	RG_35H	1280	1344	1388
	RG_45H	1845	1938	2002
	RG_55H	2079	2182	2254
	RG_65H	2931	3077	3178

Unit: N/ μm

Linear Guideways

RG series

1.7.14 Dimensions of the RG block

1.7.14.1 RGH-CA / RGH-HA

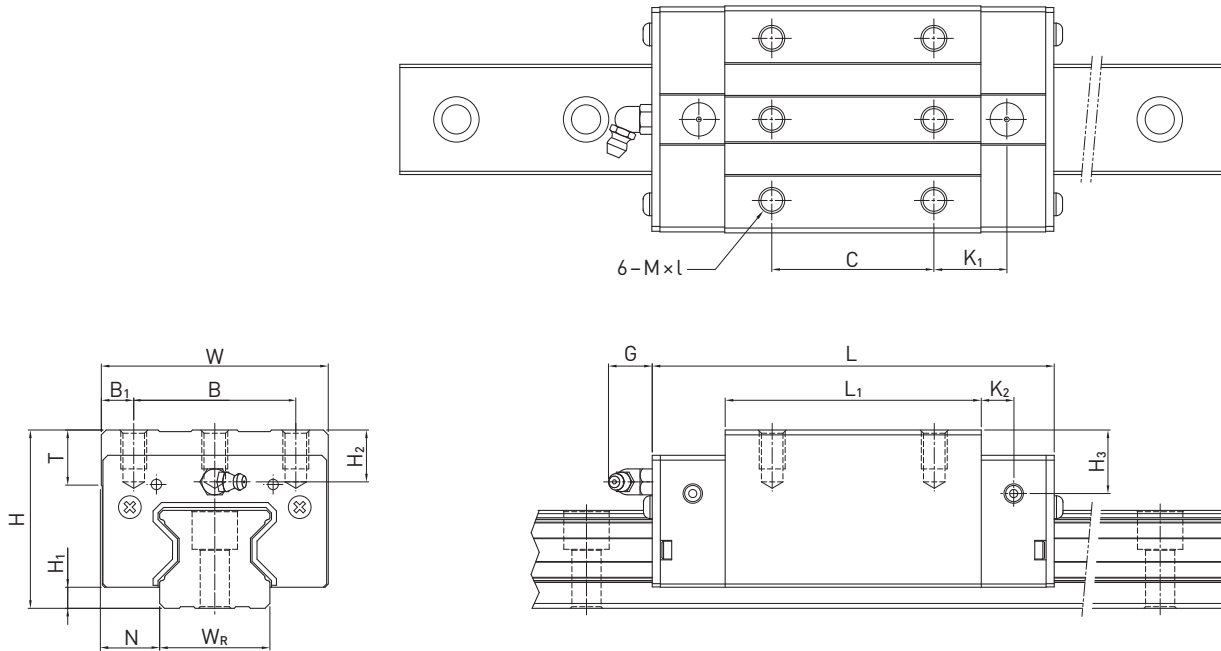

Table 1.111 Dimensions of the block

Series Size	Installation dim. [mm]			Dimensions of the block [mm]													Load Ratings [N]		Mass [kg]
	H	H ₁	N	W	B	B ₁	C	L ₁	L	K ₁	K ₂	G	M × l	T	H ₂	H ₃	C _{dyn}	C ₀	
RGH25CA	40	5,5	12,5	48	35,0	6,5	35	64,5	97,9	20,75	7,25	12,0	M6 × 8	9,5	10,20	10,0	27700	57100	0,61
RGH25HA							50	81,0	114,4	21,50							33900	73400	0,75
RGH30CA	45	6,0	16,0	60	40,0	10,0	40	71,0	109,8	23,50	8,00	12,0	M8 × 10	9,5	9,50	10,3	39100	82100	0,90
RGH30HA							60	93,0	131,8	24,50							48100	105000	1,16
RGH35CA	55	6,5	18,0	70	50,0	10,0	50	79,0	124,0	22,50	10,00	12,0	M8 × 12	12,0	16,00	19,6	57900	105200	1,57
RGH35HA							72	106,5	151,5	25,25							73100	142000	2,06
RGH45CA	70	8,0	20,5	86	60,0	13,0	60	106,0	153,2	31,00	10,00	12,9	M10 × 17	16,0	20,00	24,0	92600	178800	3,18
RGH45HA							80	139,8	187,0	37,90							116000	230900	4,13
RGH55CA	80	10,0	23,5	100	75,0	12,5	75	125,5	183,7	37,75	12,50	12,9	M12 × 18	17,5	22,00	27,5	130500	252000	4,89
RGH55HA							95	173,8	232,0	51,90							167800	348000	6,68
RGH65CA	90	12,0	31,5	126	76,0	25,0	70	160,0	232,0	60,80	15,80	12,9	M16 × 20	25,0	15,00	15,0	213000	411600	8,89
RGH65HA							120	223,0	295,0	67,30							275300	572700	12,13

Dimensions of the rail see page 82, standard- and optional lubrication adapters see page 84.

1.7.14.2 RGW-CC / RGW-HC

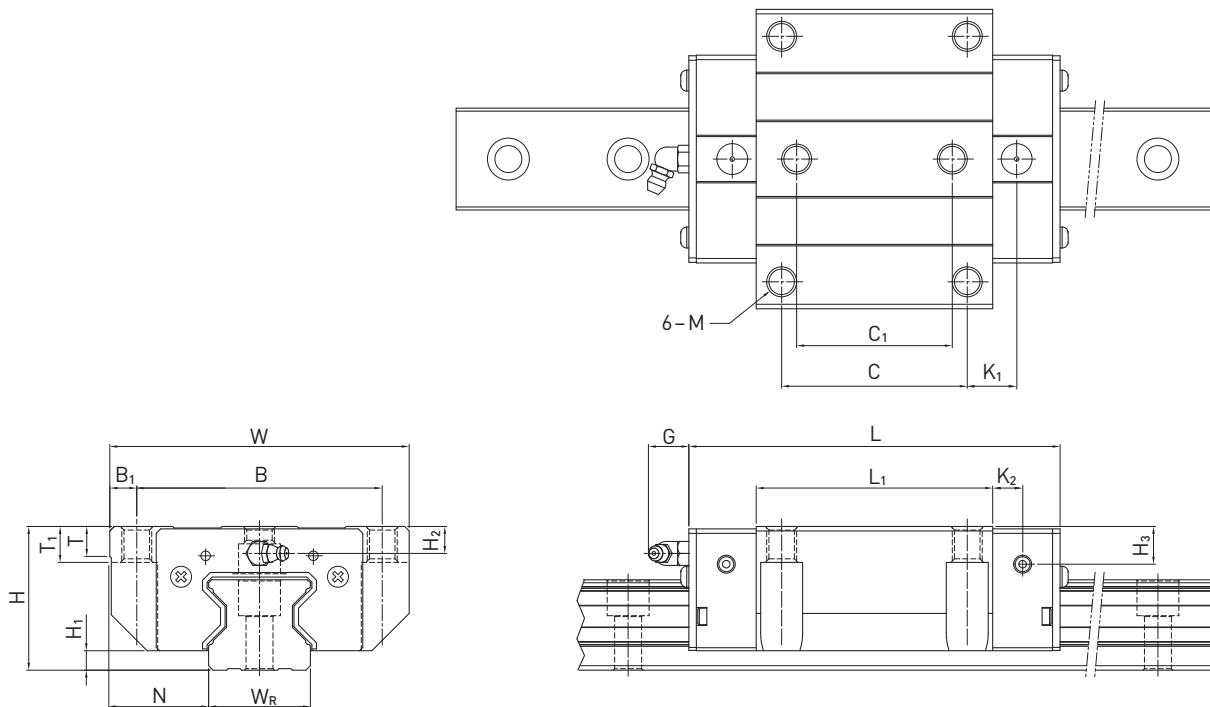

Table 1.112 Dimensions of the block

Series Size	Installation dimensions [mm]			Dimensions of the block [mm]													Load Ratings [N]		Mass [kg]		
	H	H ₁	N	W	B	B ₁	C	C ₁	L ₁	L	K ₁	K ₂	G	M	T	T ₁	H ₂	H ₃		C _{dyn}	C ₀
RGW25CC	36	5,5	23,5	70	57	6,5	45	40	64,5	97,9	15,75	7,25	12,0	M8	9,5	10	6,20	6,0	27700	57100	0,72
RGW25HC									81,0	114,4	24,00								33900	73400	0,91
RGW30CC	42	6,0	31,0	90	72	9	52	44	71,0	109,8	17,50	8,00	12,0	M10	9,5	10	6,50	7,3	39100	82100	1,16
RGW30HC									93,0	131,8	28,50								48100	105000	1,52
RGW35CC	48	6,5	33,0	100	82	9	62	52	79,0	124,0	16,50	10,00	12,0	M10	12,0	13	9,00	12,6	57900	105200	1,75
RGW35HC									106,5	151,5	30,25								73100	142000	2,40
RGW45CC	60	8,0	37,5	120	100	10	80	60	106,0	153,2	21,00	10,00	12,9	M12	14,0	15	10,00	14,0	92600	178800	3,43
RGW45HC									139,8	187,0	37,90								116000	230900	4,57
RGW55CC	70	10,0	43,5	140	116	12	95	70	125,5	183,7	27,75	12,50	12,9	M14	16,0	17	12,00	17,5	130500	252000	5,43
RGW55HC									173,8	232,0	51,90								167800	348000	7,61
RGW65CC	90	12,0	53,5	170	142	14	110	82	160,0	232,0	40,80	15,80	12,9	M16	22,0	23	15,00	15,0	213000	411600	11,63
RGW65HC									223,0	295,0	72,30								275300	572700	16,58

Dimensions of the rail see page 82, standard- and optional lubrication adapters see page 84.

Linear Guideways

RG series

1.7.15 Dimensions of the RG rail

1.7.15.1 Dimensions RGR_R

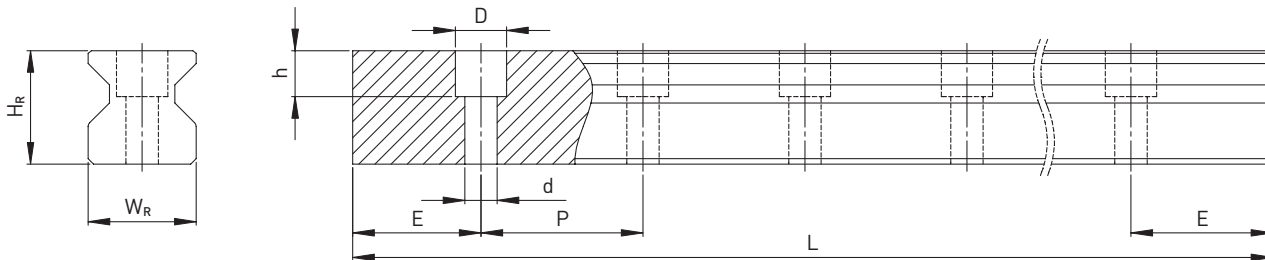

Table 1.113 Dimensions of the rail RGR_R

Series Size	Screws for rail [mm]	Dimensions of the rail [mm]						Max. length [mm]	Max. length $E_1 = E_2$	$E_{1/2}$ min [mm]	$E_{1/2}$ max [mm]	Mass [kg/m]
		W_R	H_R	D	h	d	P					
RGR25R	M6 × 20	23	23,6	11,0	9,0	7,0	30,0	4000	3960	8	22	3,08
RGR30R	M8 × 25	28	28,0	14,0	12,0	9,0	40,0	4000	3920	9	31	4,41
RGR35R	M8 × 25	34	30,2	14,0	12,0	9,0	40,0	4000	3920	9	31	6,06
RGR45R	M12 × 35	45	38,0	20,0	17,0	14,0	52,5	4000	3937,5	12	40,5	9,97
RGR55R	M14 × 45	53	44,0	23,0	20,0	16,0	60,0	4000	3900	14	46	13,98
RGR65R	M16 × 50	63	53,0	26,0	22,0	18,0	75,0	4000	3900	15	60	20,22

1.7.15.2 Dimensions RGR_T (rail mounting from below)

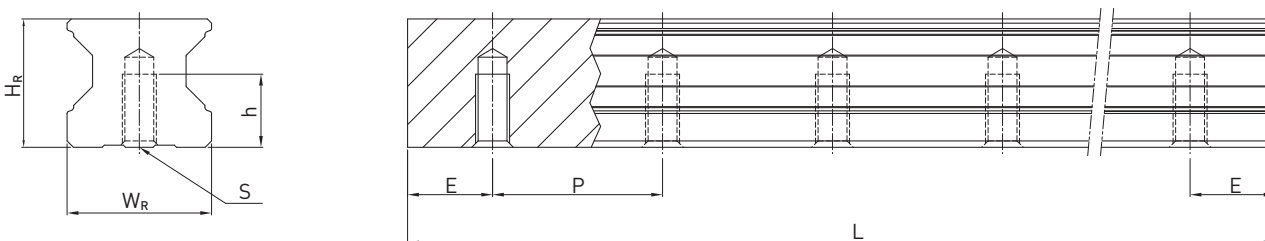

Table 1.114 Dimensions of the rail RGR_T

Series Size	Dimensions of the rail [mm]					Max. length [mm]	Max. length $E_1 = E_2$	$E_{1/2}$ min [mm]	$E_{1/2}$ max [mm]	Mass [kg/m]
	W_R	H_R	S	h	P					
RGR25T	23	23,6	M6	12,0	30,0	4000	3960	8	22	3,08
RGR30T	28	28,0	M8	15,0	40,0	4000	3920	9	31	4,41
RGR35T	34	30,2	M8	17,0	40,0	4000	3920	9	31	6,06
RGR45T	45	38,0	M12	24,0	52,5	4000	3937,5	12	40,5	9,97
RGR55T	53	44,0	M14	24,0	60,0	4000	3900	14	46	13,98
RGR65T	63	53,0	M20	30,0	75,0	4000	3900	15	60	20,22

Note:

1. The tolerance for E is +0,5 to -1 mm for standard, for joint connections 0 to -0,3 mm
2. If no information is provided on the $E_{1/2}$ dimensions, the maximum number of fixing holes is determined taking into account $E_{1/2}$ min
3. The rails are shortened to the desired length. If no information on the $E_{1/2}$ dimensions is provided, then the rails are manufactured symmetrically.

1.7.15.3 Calculation of the length of profile rails

HIWIN offers customer-specific lengths. To ensure that the ends of the rails for nonstandard lengths are stable, value E must not exceed half the distance between the fixing holes (P). In addition, value $E_{1/2}$ must not be less than $E_{1/2 \text{ min}}$ and must not exceed $E_{1/2 \text{ max}}$ to prevent breakage of the fixing hole.

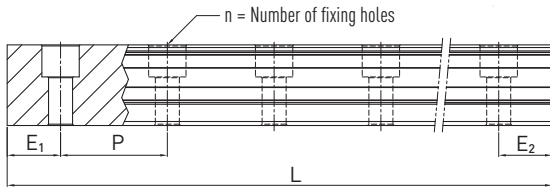

$$L = (n-1) \cdot P + E_1 + E_2$$

- L: Total rail length [mm]
- n: Number of fixing holes
- P: Distance between two fixing holes [mm]
- $E_{1/2}$: Distance from the center of the last fixing hole to the end of the rail [mm]

1.7.15.4 Tightening torques for fixing screws

Insufficient tightening of the fixing screws will highly detract from the accuracy of the linear guideway. The following tightening torques are recommended for the respective screw sizes.

Table 1.116 Tightening torques for fixing screws to ISO 4762-12.9

Series/Size	Screw size	Torque [Nm]	Series/Size	Screw size	Torque [Nm]
RG_25	M6 × 20	14	RG_45	M12 × 35	120
RG_30	M8 × 25	31	RG_55	M14 × 45	160
RG_35	M8 × 25	31	RG_65	M16 × 50	200

1.7.15.5 Cover cap for rail fixing holes

The cover caps are used to keep the fixing holes free from chips and dirt. The standard plastic bolt caps are enclosed to each rail. Optional caps have to be ordered extra.

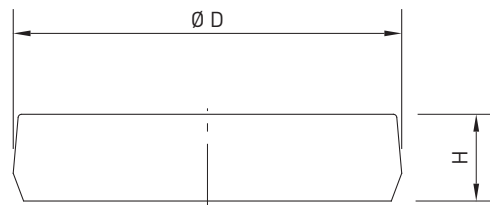

Table 1.117 Cover cap for rail fixing holes

Rail	Screw	Article number			Ø D [mm]	Height H [mm]
		Plastic	Brass (optional)	Steel		
RGR25R	M6	C6	C6-M	C6-ST	11	2,5
RGR30R	M8	C8	C8-M	C8-ST	14	3,3
RGR35R	M8	C8	C8-M	C8-ST	14	3,3
RGR45R	M12	C12	C12-M	C12-ST	20	4,6
RGR55R	M14	C14	C14-M	C14-ST	23	5,5
RGR65R	M16	C16	C16-M	C16-ST	26	5,5

Linear Guideways

Accessory

1.8 Accessory

1.8.1 Lubrication fittings

By default, the block is equipped with a lubrication nipple on one end. It is also possible to install it on the side of the block. In this case, the lubrication nipple should not be installed on the reference side. It is also possible to use a lubrication tube connector for lubrication.

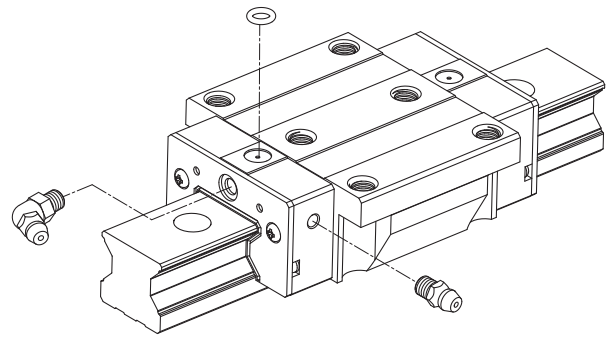

Table 1.118 Grease nipples for grease lubrication

<p>M3 x 0,5P</p>	<p>M4 x 0,7P</p>	<p>M6 x 0,75P</p>
<p>Art.No.: 34310006 MG15, WE17 (Standard)</p>	<p>Art.No.: 34310002 HG15, QH15, EG15, QE15 (Standard)</p>	<p>Art.No.: 34320001 HG20-HG35, QH20-QH35, EG20-EG35, QE20-QE35, WE21-WE35, RG25-RG35 (Standard)</p>
<p>M6 x 0,75P</p>	<p>PT 1/8</p>	<p>PT 1/8</p>
<p>Art.No.: 34310008 HG20-HG35, QH20-QH35, EG20-EG35, QE20-QE35, WE21-WE35, RG25-RG35 (Option)</p>	<p>Art.No.: 34320003 HG45-HG65, QH45, RG45-RG65 (Standard)</p>	<p>Art.No.: 3431000B HG45-HG65, QH45, RG45-RG65 (Option)</p>

The article numbers given apply to the standard dust protection equipment. Article numbers for optional dust protection equipment are available on request.

Table 1.119 Lubrication fittings for oil lubrication

<p>SF-76 Art.No.: 970001A1 HG20-HG35, QH20-QH35, EG20-EG35, QE20-QE35, WE21-WE35, RG25-RG35</p>	<p>SF-78 Art.No.: 970005A1 HG45-HG65, QH45, RG45-RG65</p>	<p>SF-86 Art.No.: 970003A1 HG20-HG35, QH20-QH35, EG20-EG35, QE20-QE35, WE21-WE35, RG25-RG35</p>
<p>SF-88 Art.No.: 970007A1 HG45-HG65, QH45, RG45-RG65</p>	<p>LF-64 Art.No.: 97000EA1 HG15, QH15, EG15, QE15</p>	<p>LF-76 Art.No.: 970002A1 HG20-HG35, QH20-QH35, EG20-EG35, QE20-QE35, WE21-WE35, RG25-RG35</p>
<p>LF-78 Art.No.: 970006A1 HG45-HG65, QH45, RG45-RG65</p>	<p>LF-86 Art.No.: 970004A1 HG20-HG35, QH20-QH35, EG20-EG35, QE20-QE35, WE21-WE35, RG25-RG35</p>	<p>LF-88 Art.No.: 970008A1 HG45-HG65, QH45, RG45-RG65</p>

The article numbers given apply to the standard dust protection equipment. Article numbers for optional dust protection equipment are available on request.

Linear Guideways

Accessory

Table 1.120 **Push-on connector**

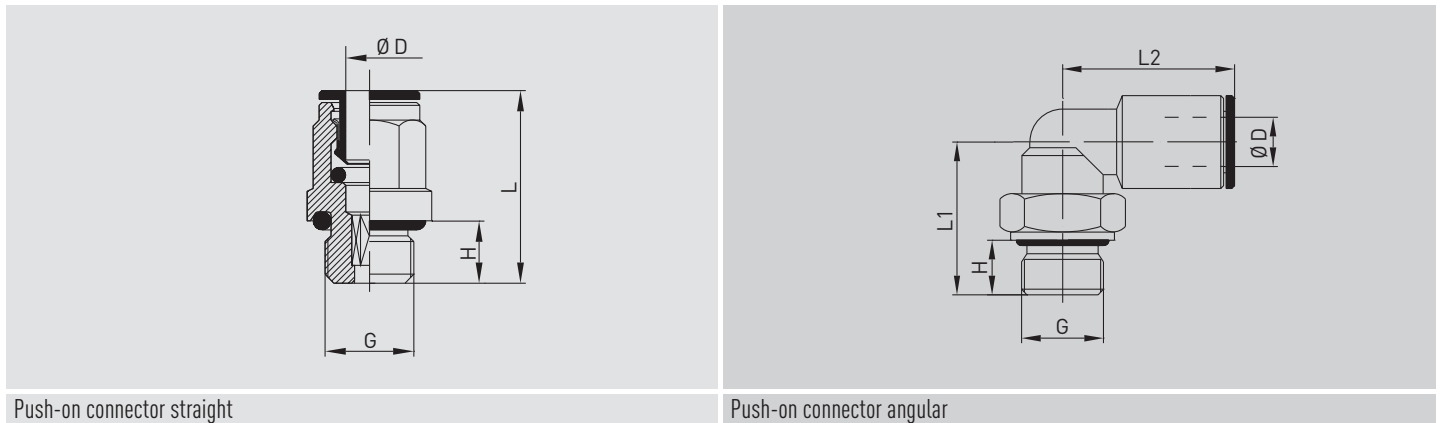

Table 1.121 **Dimensions of the push-on connectors**

Article Number	Ø D	G	Form	H	L	L1	L2
8-12-0127	4	M6 × 0,75	straight	5	23,5	—	—
8-12-0131	4	G 1/8	straight	6	20,0	—	—
8-12-0136	6	G 1/8	straight	6	24,0	—	—
8-12-0128	4	M6 × 0,75	angular	5	—	15,5	18,0
8-12-0138	6	M6 × 0,75	angular	5	—	15,5	20,0
8-12-0130	4	G 1/8	angular	6	—	20,0	20,0
8-12-0137	6	G 1/8	angular	6	—	20,0	21,0

The article numbers given apply to the standard dust protection equipment. Article numbers for optional dust protection equipment are available on request.

1.8.2

For one thing, the HIWIN end seals prevent foreign matter – such as dirt particles, chips or fluids – from intruding into the ball raceways of the sliding carriage; for another, they reduce the discharging of the lubricant.

HIWIN offers various sealing systems for the different ambient conditions of your application. The effectiveness of the end seal has a direct influence on the service life of the profiled rail guide, and should therefore already be taken into account in the design and be chosen appropriate to the ambient conditions of its application."

SS (Standard):

End seal with bottom seal

- For applications with low dirt and dust exposure
- Only minimal increase in displacement forces

ZZ:

End seal with bottom seal and scraper

- For applications in conjunction with hot swarfs or sharp-edged dirt particles
- The sheet-metal scraper protects the end seals and prevents them from getting damaged

DD:

Double end seal with bottom seal

- For applications in conjunction with heavy dirt and dust exposure
- The double end seal effectively prevents dirt from penetrating into the block

KK:

Double end seals with bottom seal and scraper

- For applications with heavy dirt and dust exposure and hot or sharp-edged metal particles
- The sheet-metal scraper protects the end seals from getting damaged

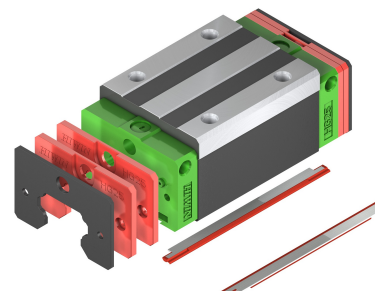
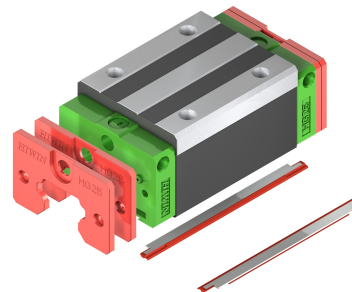
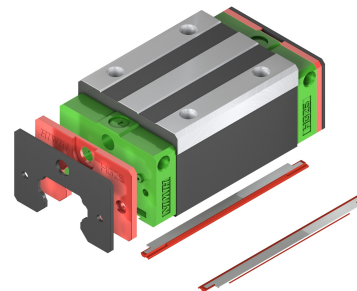
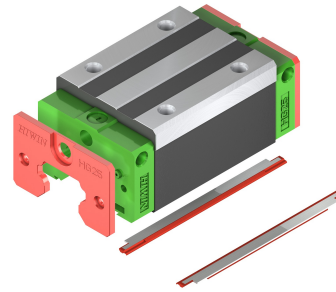

SS, ZZ, DD and KK sealing system availability:

The SS, ZZ, DD, and KK sealing systems are available for all model series and design sizes. The MG model series is an exception, only the SS standard sealing system is available for it.

Linear Guideways

Accessory

1.8.3 SW and ZWX sealing systems for optimum protection against dust

The SW and ZWX sealing systems make it possible to also use HIWIN profiled rail guides in areas that are highly contaminated with dirt.

- End seal with double sealing lip
- Optimized base seal
- Additional head seal
- Optimized stainless steel wiper

SW:

End seal with a double lip, optimized lower sealing strip and additional head seal.

- The additional head seal prevents dirt from penetrating through the top side of the rail
- The optimized base seal protects against penetration of dirt on the side of the rails

ZWX:

End seal with a double lip, optimized lower sealing strip, additional head seal and optimized stainless steel wiper.

- Optimum protection against dust
- The optimized stainless steel wiper also protects against dirt particles larger than 0.2mm in diameter and prevents damage to the end seal.
- The optimized base seal protects against penetration of dirt on the side of the rails
- The additional head seal prevents dirt from penetrating through the top side of the rail.

The sealing systems offer optimum protection against the intrusion of dirt, dust and fluids. The end seal has a high wear resistance and is resistant to oils and greases.

- Optimum protection against dust
- 10x extended service life
- Extended lubrication intervals
- Lower maintenance costs

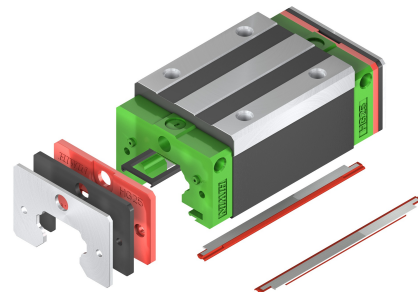
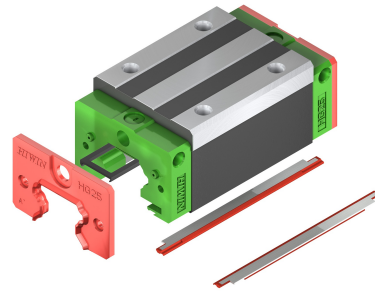

Dust test of the SW and ZWX sealing systems

Thorough dust tests have proven that, under extreme contamination with dirt, the service life with the SW and ZWX sealing systems is 10 times longer than the service life with standard seals.

Test conditions:

- Enclosed room with swirling MDF dust
- $v = 1,3 \text{ m/s}$
- Grease lubrication

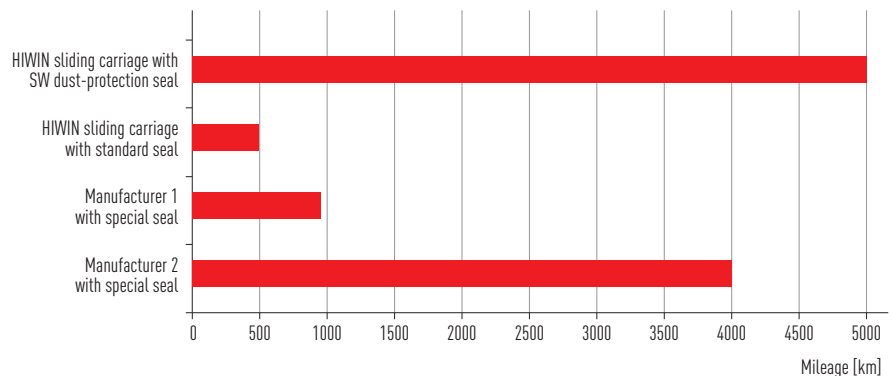

Table 1.122 Availability of SW and ZWX sealing systems

Series	Size							
	15	20	25	30	35	45	55	65
HG	○	●■	●■	●■	●■	●■	○□	○□
RG						○□	○□	○□

- SW sealing system, ○ SW sealing system (without head seal and opt. base seal)
- ZWX sealing system, □ ZWX sealing system (without head seal and opt. base seal)

2. Ballscrews

Ballscrews consist of ballscrew shaft and ballscrew nut, within which the balls and a ball return system are integrated. The distinguishing features of HIWIN ballscrews are low-friction, accurate running, a low drive torque requirement and a high level of rigidity combined with quiet operation. HIWIN has state-of-the-art production facilities, highly qualified engineers, quality-assured manufacturing and assembly processes, using only high-quality materials to satisfy your demands.

2.1 Product Overview

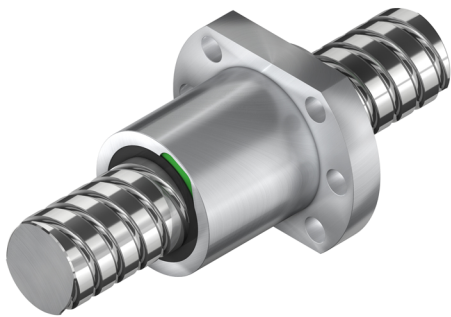

Rolled Ballscrews

Page 92

- Nut dimensions according DIN 69051 Part 5
- Minimal axial backlash or free of play
- Nominal diameter 8 – 63 mm
- Standardized shaft ends

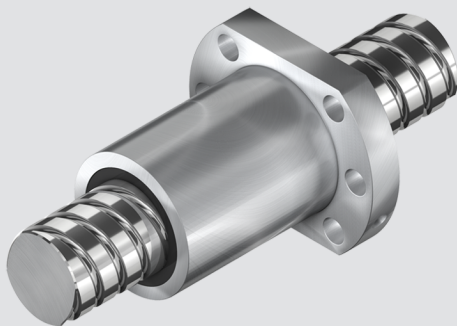

Peeled Ballscrews

Page 96

- Flange and cylindrical nuts
- Single and double nuts
- Nominal diameter 16 – 80 mm
- Standardized shaft ends

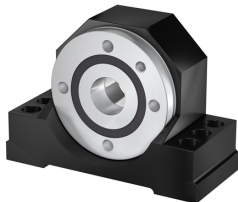

Accessory

Page 104

- Standard shaft ends
- Standard bearings
- Nut housing

Ballscrews

Product Overview

2.1.2 HIWIN ballscrews

HIWIN manufactures ballscrews according to customer drawings or with standard HIWIN end processing. The following points have to be defined or checked for the definition of the ballscrew. This ensures that the ballscrew is optimally adapted to the existing requirements.

1. Nominal diameter
2. Lead
3. Total thread length
4. Design of the bearing seats
5. Design of the ballscrew nut
6. Accuracy class (lead variation, tolerances)
7. Operating speed
8. Maximum static load, operating load, pretension friction torque
9. Safety requirements of the ballscrew nut
10. Position of the lubrication holes

2.1.3 HIWIN order key

For unambiguous identification of the ballscrew, informations about the ballscrew spindle and ballscrew nut is required.

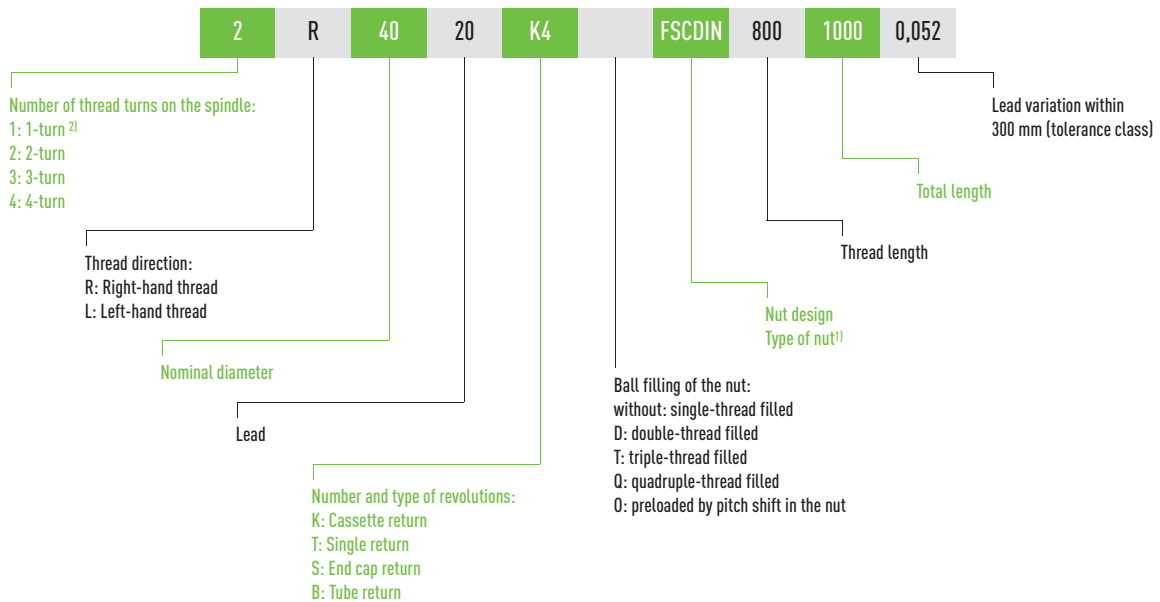

2.1.4 Information about ballscrew spindle without ballscrew nut

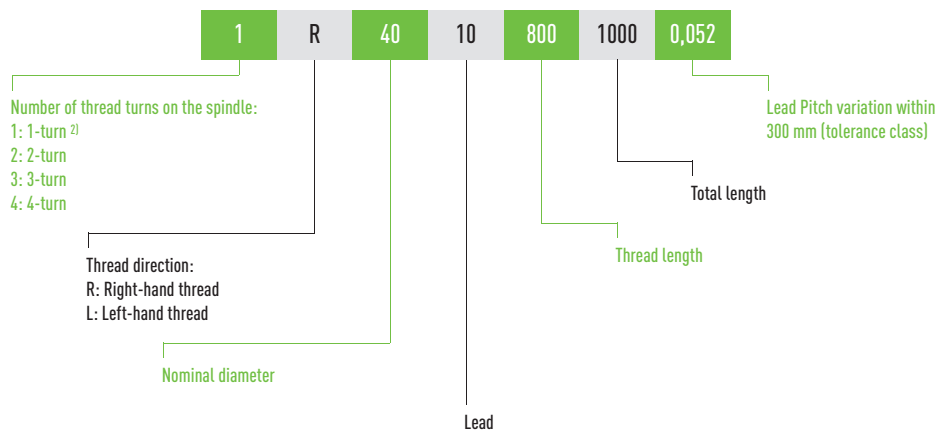

1) see table 2.1

2) Standard – can be omitted for single-turn spindles

2.1.5 Information about ballscrew spindle without ballscrew nut

The nut designations differ, depending on whether the ballscrew is rolled, peeled or ground.

Information about ballscrew nut:

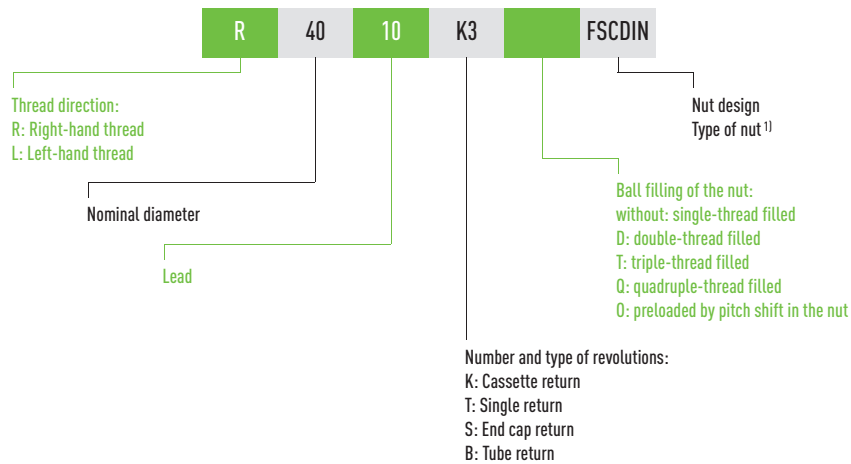

1) see Table 2.1

Table 2.1 Overview of nut designs

Nut designation	Description
DEB	Flanged single nut in accordance with DIN 69051, Part 5 for peeled ballscrew spindles
DDB	Flanged double nut in accordance with DIN 69051, Part 5 for peeled ballscrew spindles
FSIDIN FSCDIN	Flanged single nut in accordance with DIN 69051, Part 5 for rolled and ground ballscrew spindles. For customer-specific flanged nuts that do not correspond to DIN, the "DIN" suffix is omitted
RSI	Cylindrical single nut for rolled and ground ballscrew spindles
RSIT	Cylindrical single nut with internal thread for rolled ballscrew spindles
SE	Cylindrical single nut with internal thread for peeled ballscrew spindles
SEM	Flanged single nut with integrated safety nut for peeled ballscrew spindles
ZE	Cylindrical single nut for peeled ballscrew spindles
ZD	Cylindrical double nut for peeled ballscrew spindles

Ballscrews

Rolled Ballscrews

2.2 Rolled Ballscrews

2.2.1 Properties

Rolled ballscrews have the advantage of less friction and smoother running in the feed systems compared to conventional threads.

HIWIN relies on the latest technologies in the rolling process for its manufacturing by having the processes of material selection, rolling, heat treatment, processing, and installation coordinated as best possible.

Rolled ballscrews from HIWIN can be used with great versatility in almost all areas of the industry. Rolled ballscrew spindles can be shipped with a short delivery time with corresponding stockkeeping in the diameter range from 8 mm to 63 mm. You can choose to have them delivered with or without end processing. Complete bearing units in conjunction with standardized spindle ends enable shipping of complete ballscrews from a single source.

2.2.2 Tolerance classes

Table 2.2 shows the tolerance classes of the rolled ballscrews. The pitch accuracy is defined by the deviation from the target path over any 300-mm stretch within the total length.

Table 2.2 Tolerance classes of the rolled ballscrews

Path deviation	Tolerance class		
	5	7	10
V_{300p}	0,023	0,052	0,21

Unit: mm

Limit deviation e_p $e_p = \pm \frac{l_u}{300} \cdot V_{300p}$ l_u Useful path
 V_{300p} Permitted path deviation over a 300-mm path

2.2.3 Overview of the rolled ballscrews that can be delivered

Table 2.3 Overview of the rolled ballscrews

Nominal diameter	Lead																		Max. spindle length
	1	1,25	2	2,5	3	4	5	5,08	6	8	10	12	16	20	25	32	40	50	
6	○	○																	500
8			○	●□	○														800
10			○	●□	○	○□	○												1500
12			○	●	○	●□	○	○				○	○		○				1500
15							○				○				○				1500
16			●	●		○	●□	●			●□		○□			○			3000
20				●		○	●□	●	○	○	○□			○□					3000
25						○	●□	●		○	●□				○□				4500
32						○	●□	●	○	○	○□			□	○	○□			4500
36							○	○	○	○					○				4500
40							●□	●	○	○	○□			□	○		○□		4500
50							○□		○		○□			□	○		○□	○	5600
63											●□				●		○		5600

Unit: mm

- Right- and left-hand thread
- Only right-hand thread
- Preferred type for right-hand thread with fast delivery time

2.2.4 Ballscrew nuts for rolled ballscrews

The ballscrew nuts in the following list are available ex stock in tolerance class T7 and therefore can be delivered with a shorter delivery time.

Non-standard nut types and double nuts for rolled ballscrews as well as differing tolerance classes can be delivered for specific orders. To make this happen, please contact our HIWIN colleagues.

2.2.4.1 Flanged single nut FSCDIN (DIN 69051 Part 5)

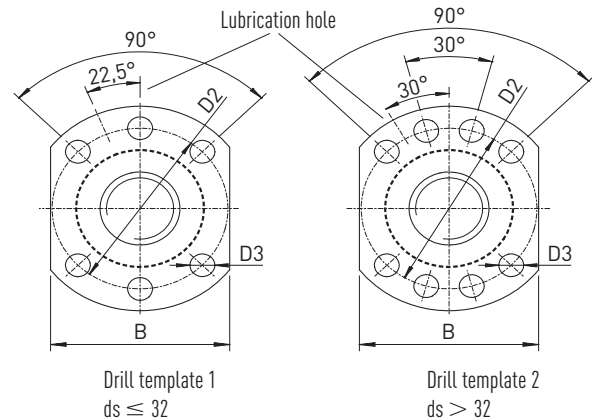
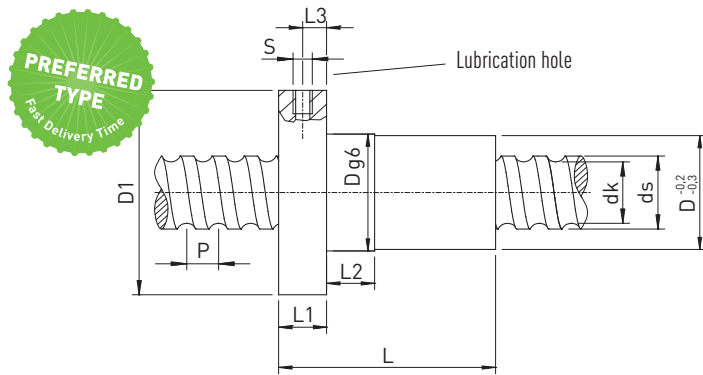

Table 2.4 Dimensions of the nut – Part 1

Article number	ds ±0,1	P	D g6	D1	D2	D3	Drill templ- ate	L	L1	L2	L3	S	B	dk	Dyn. Load C _{dyn} [N]	Stat. Load C ₀ [N]	Axial play max. [mm]	Mass [kg/pc.]
R15-05K4-FSCDIN	13,8	5	28	48	38	5,5	1	38	10	10	5	M6	40	11,8	12600	21000	0,04	0,17
R16-05T3-FSIDIN	15,5	5	28	48	38	5,5	1	40	10	10	5	M6	40	12,9	7320	12470	0,04	0,17
R16-10K3-FSCDIN	14,6	10	28	48	38	5,5	1	45	10	10	5	M6	40	12,5	9100	19300	0,04	0,19
R16-16K3-FSCDIN	14,4	16	28	48	38	5,5	1	61	12	20	6	M6	40	13,0	9100	19300	0,04	0,30
R20-05K4-FSCDIN	19,5	5	36	58	47	6,6	1	40	10	10	5	M6	44	16,9	13400	32740	0,04	0,29
R20-10K3-FSCDIN	19,3	10	36	58	47	6,6	1	48	10	10	5	M6	44	16,6	10000	23500	0,04	0,32
R20-20K2-FSCDIN	19,5	20	36	58	47	6,6	1	57	10	10	5	M6	44	17,1	6800	15300	0,04	0,36
R20-20K4-DFSCDIN	19,5	20	36	58	47	6,6	1	57	10	10	5	M6	44	17,1	12300	30500	0,04	0,36
R25-05K4-FSCDIN	24,9	5	40	62	51	6,6	1	43	10	12	5	M6	48	22,3	14900	41500	0,04	0,31
R25-10K4-FSCDIN	24,4	10	40	62	51	6,6	1	61	10	16	5	M6	48	21,8	15900	40400	0,04	0,39
R25-25K2-FSCDIN	24,7	25	40	62	51	6,6	1	70	10	16	5	M6	48	22,1	7400	19100	0,04	0,43
R25-25K4-DFSCDIN	24,7	25	40	62	51	6,6	1	70	10	16	5	M6	48	22,1	13500	38200	0,04	0,43
R32-05K6-FSCDIN	31,7	5	50	80	65	9,0	1	48	12	10	6	M6	62	29,1	23900	81900	0,04	0,59
R32-10K5-FSCDIN	31,8	10	50	80	65	9,0	1	77	12	16	6	M6	62	28,6	31500	80100	0,04	1,02
R32-20K3-FSCDIN	31,8	20	50	80	65	9,0	1	88	12	16	7	M6	62	28,6	17000	48500	0,04	1,02
R32-32K2-FSCDIN	31,9	32	50	80	65	9,0	1	88	12	20	6	M6	62	28,7	11600	31800	0,04	1,20
R32-32K4-DFSCDIN	31,9	32	50	80	65	9,0	1	88	12	20	6	M6	62	28,7	20600	62200	0,04	1,33
R40-05K6-FSCDIN	39,4	5	63	93	78	9,0	2	50	14	10	7	M8 × 1	70	36,8	25900	100600	0,04	1,10
R40-10K4-FSCDIN	37,8	10	63	93	78	9,0	2	70	14	16	7	M8 × 1	70	32,8	45000	123000	0,04	1,25
R40-20K3-FSCDIN	37,8	20	63	93	78	9,0	2	88	14	16	7	M8 × 1	70	32,8	34850	90000	0,07	1,45
R40-40K2-FSCDIN	37,8	40	63	93	78	9,0	2	102	14	16	7	M8 × 1	70	32,9	23000	58400	0,07	1,60
R40-40K4-DFSCDIN	37,8	40	63	93	78	9,0	2	102	14	16	7	M8 × 1	70	32,9	41500	115800	0,07	1,60

Ballscrews

Rolled Ballscrews

Table 2.4 Dimensions of the nut – Part 2

Article number	ds ±0,1	P	D g6	D1	D2	D3	Drill templ- ate	L	L1	L2	L3	S	B	dk	Dyn. Load C _{dyn} [N]	Stat. Load C ₀ [N]	Axial play max. [mm]	Mass [kg/pc.]
R50-05K6-FSCDIN	49,3	5	75	110	93	11,0	2	50	16	10	8	M8 × 1	85	46,8	28300	127200	0,07	1,30
R50-10K6-FSCDIN	47,9	10	75	110	93	11,0	2	90	16	20	8	M8 × 1	85	42,9	74500	250000	0,07	2,20
R50-20K6-FSCDIN	48	20	75	110	93	11,0	2	132	18	25	9	M8 × 1	85	42,9	67200	217500	0,07	2,50
R50-40K3-FSCDIN	50,3	40	75	110	93	11,0	2	149	18	45	9	M8 × 1	85	45,0	39000	123000	0,07	3,30
R50-40K6-DFSCDIN	50,3	40	75	110	93	11,0	2	149	18	45	9	M8 × 1	85	45,0	70300	242600	0,07	3,37
R63-10T6-FSIDIN	63,1	10	90	125	108	11,0	2	120	18	16	9	M8 × 1	95	58,0	61920	214090	0,07	3,10

- DIN nuts for rolled ballscrew spindles
- Mating dimensions to DIN 69051 Part 5
- Nuts with polyamide wipers
- Precision ground ball grooves
- Reduced axial play on request
- FSC DIN: total return
- FSI DIN: single return

Order example: **R** **25** **10** **K4** **FSCDIN** **650** **730** **0,052**

2.2.4.2 Cylindrical single nut RSIT with screw thread

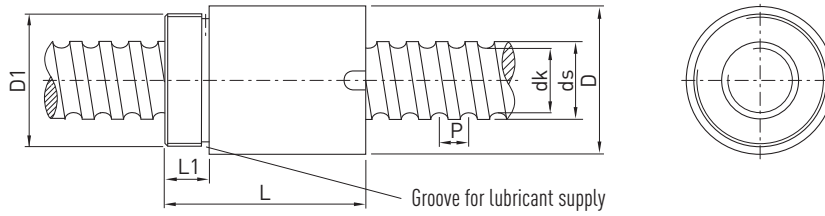

Table 2.5 Dimensions of the nut

Article number	ds	P	D -0,2	D1	L -0,5	L1	dk	Dyn. Load C_{dyn} [N]	Stat. Load C_0 [N]	Axial play max. [mm]	Mass [kg/pc.]
R08-02,5T2-RSIT	7,7	2,5	17,5	M15 × 1	27,5	7,5	6,1	1200	3360	0,04	0,04
R10-02,5T2-RSIT	9,3	2,5	19,5	M17 × 1	25,0	7,5	8,1	1780	2630	0,04	0,06
R10-04T2-RSIT	9,7	4,0	24,0	M22 × 1	32,0	10,0	7,7	1980	2820	0,04	0,08
R12-04B1-RSIT	11,9	4,0	25,5	M20 × 1	34,0	10,0	9,5	3000	5700	0,04	0,10

R10-02,5T2-RSIT and R10-04T2-RSIT without wiper, R08-02,5T2-RSIT and R12-04B1-RSIT with single-sided polyamide wiper.

- Reduced axial play on request
- Nuts with wipers
- Precision ground ball grooves

Order example: **R** 12 **4** **B1** **RSIT** 350 **405** **0,052**

2.2.4.3 Cylindrical single nut RSI

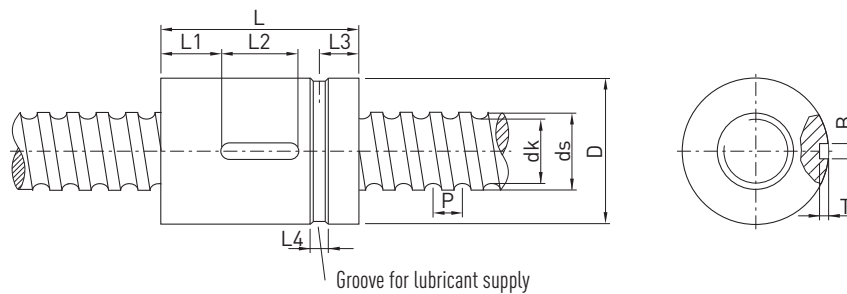

Table 2.6 Dimensions of the nut

Article number	ds ±0,1	P	D g7	L ±0,2	L1	L2	L3	L4	T +0,1	B P9	dk	Dyn. Load C_{dyn} [N]	Stat. Load C_0 [N]	Axial play max. [mm]	Mass [kg/pc.]
R16-10T3-RSI	15,3	10	28	60	8	20	9,5	5	2,5	4	12,9	6100	10800	0,04	0,19
R20-10T3-RSI	19,8	10	34	60	20	20	12,0	4	2,0	5	17,5	8100	12600	0,04	0,26

- Reduced axial play on request
- Nuts with wipers
- Precision ground ball grooves

Order example: **R** 16 **10** **T3** **RSI** 350 **405** **0,052**

Ballscrews

Peeled Ballscrews

2.3 Peeled Ballscrews

2.3.1 Properties

Peeled ballscrews from HIWIN form an intermediate qualitative stage between rolled and ground ballscrews and therefore can be used with versatility for transport or positioning applications. Upon request, we will gladly create a pitch measurement report for you for this purpose.

For peeled ballscrews, a wide variety of nut designs is available as single or double nuts. Complete ballscrews can be custom manufactured with a short delivery time. Complete bearing units in conjunction with standardized spindle ends minimize the design effort.

2.3.2 Tolerance classes

Table 2.7 shows the tolerance classes of the peeled ballscrews. The pitch accuracy is defined by the deviation from the target path over any 300-mm stretch within the total length.

Table 2.7 Tolerance classes of the peeled ballscrews

Path deviation	Tolerance class	
	5	7
V300p	0,023	0,052

Unit: mm

$$\text{Limit deviation } e_p = \pm \frac{l_u}{300} \cdot V_{300p}$$

l_u Useful path
 V_{300p} Permitted path deviation over a 300-mm path

2.3.3 Overview of the peeled ballscrews that can be delivered

Table 2.8 Overview of the peeled ballscrews

Nominal diameter	Lead				Max. spindle length ¹⁾
	5	10	20	40	
16	○□				6.000
20	○□				6.000
25	○□	○□			6.000
32	○□	○□	○□		6.000
40	○□	○□	○□	●	6.000
50	○□	○□	○□		6.000
63		○□	○□		6.000
80		○□	○□		6.000

Unit: mm

- Right- and left-hand thread
- Only right-hand thread
- Preferred type for right-hand thread with fast delivery time

¹⁾ The maximum thread length is 5,500 mm. For the max. spindle length, always take into consideration the critical speed and the max. crippling load.

2.3.4 Flanged single nut DEB (DIN 69051 Part 5)

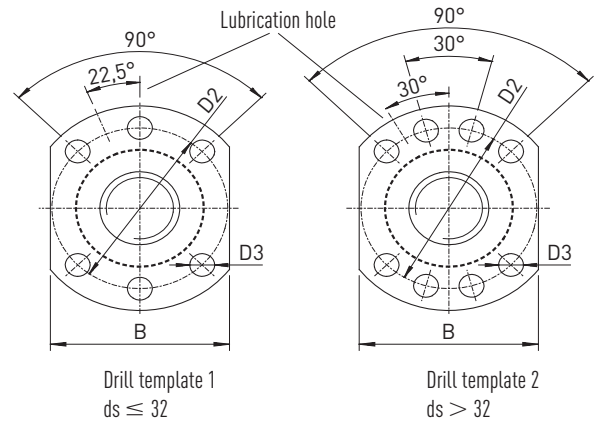
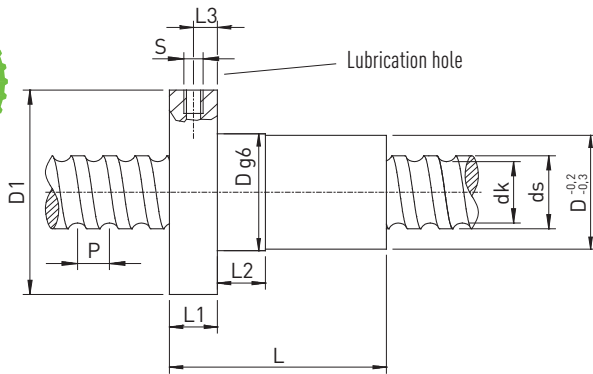

Table 2.9 Dimensions of the nut

Article number	ds h6	P	D g6	D1	D2	D3	L	L1	L2	L3	S	B	dk	Dyn. Load C _{dyn} [N]	Stat. Load C ₀ [N]	Axial play max. [mm]	Mass [kg/pc.]
R16-05T3-DEB	16	5	28	48	38	5,5	40	10	10	5,0	M6	40	13,5	9600	12700	0,02	0,17
R20-05T4-DEB	20	5	36	58	47	6,6	52	10	10	5,0	M6	44	17,5	13900	21800	0,02	0,31
R25-05T4-DEB	25	5	40	62	51	6,6	52	10	10	5,0	M6	48	22,5	15600	27900	0,02	0,32
R25-10T3-DEB	25	10	40	62	51	6,6	65	10	16	5,0	M6	48	21,0	24100	36200	0,02	0,35
R32-05T5-DEB	32	5	50	80	65	9,0	60	12	10	6,0	M6	62	29,5	20700	43900	0,02	0,68
R32-10T4-DEB	32	10	50	80	65	9,0	85	14	16	7,0	M6	62	27,8	40900	63200	0,02	0,82
R32-20T2-DEB	32	20	50	80	65	9,0	80	14	16	7,0	M6	62	27,8	20300	26800	0,02	0,68
R40-05T5-DEB	40	5	63	93	78	9,0	69	14	10	7,0	M8 × 1	70	37,5	22500	54600	0,02	1,13
R40-10T4-DEB	40	10	63	93	78	9,0	88	14	16	7,0	M8 × 1	70	35,8	46800	82600	0,02	1,13
R40-20T2-DEB	40	20	63	93	78	9,0	88	14	16	7,0	M8 × 1	70	35,8	23800	36400	0,03	1,14
R50-05T5-DEB	50	5	75	110	93	11,0	69	16	10	8,0	M8 × 1	85	47,5	24900	69800	0,02	1,45
R50-10T4-DEB	50	10	75	110	93	11,0	98	16	16	8,0	M8 × 1	85	45,8	52800	106800	0,02	1,65
R50-20T3-DEB	50	20	75	110	93	11,0	114	16	16	8,0	M8 × 1	85	45,8	40000	76200	0,03	1,95
R63-10T6-DEB	63	10	90	125	108	11,0	120	18	16	9,0	M8 × 1	95	58,8	84700	210800	0,04	3,05
R63-20T4-DEB	63	20	95	135	115	13,5	150	20	25	10,0	M8 × 1	100	55,4	105000	250000	0,04	3,85
R63-20T5-DEB	63	20	95	135	115	13,5	175	20	25	10,0	M8 × 1	100	55,4	125000	300000	0,04	4,30
R63-20K6-DEBH	63	20	125	165	145	13,5	170	25	25	12,0	M8 × 1	130	50,2	245700	783300	0,04	13,60
R80-10T6-DEB	80	10	105	145	125	13,5	120	20	16	10,0	M8 × 1	110	75,8	93400	269200	0,04	3,20
R80-20T4-DEB	80	20	125	165	145	13,5	160	25	25	12,0	M8 × 1	130	72,4	135000	322000	0,05	8,95
R80-20T5-DEB	80	20	125	165	145	13,5	175	25	25	12,0	M8 × 1	130	72,4	161500	398000	0,05	9,25
R80-20K6-DEBH	78	20	135	175	155	13,5	170	25	25	12,5	M8 × 1	140	68,2	280000	720000	0,05	13,00
R80-20K7-DEBH	78	20	135	175	155	13,5	190	25	25	12,5	M8 × 1	140	68,2	320000	820000	0,05	14,30

- Reduced axial play on request
- DIN nuts for peeled ballscrew spindles
- Mating dimensions to DIN 69051 Part 5
- Nuts with dust wipers
- Precision ground ball grooves
- Left-hand nuts on request
- Nut-housing (page 110)

Order example: **R** **63** **10** **T6** **DEB** **3850** **3972** **0,052**

Ballscrews

Peeled Ballscrews

2.3.5 Flanged double nut DDB (DIN 69051 Part 5)

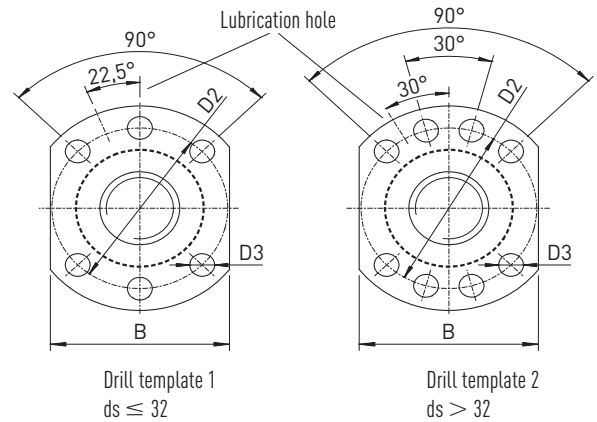
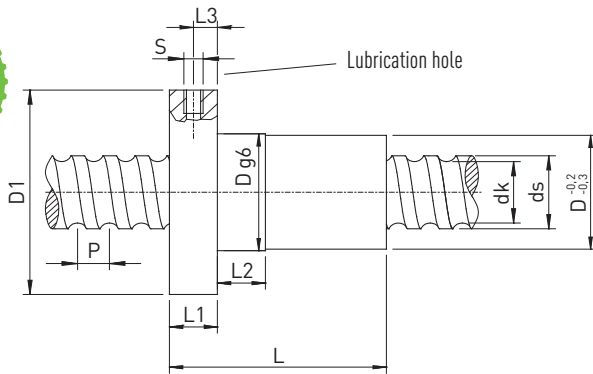

Table 2.10 Dimensions of the nut

Article number	ds h6	P	D g6	D1	D2	D3	L	L1	L2	L3	S	B	dk	Dyn. Load C _{dyn} [N]	Stat. Load C ₀ [N]	Mass [kg/pc.]
R16-05T3-DDB	16	5	28	48	38	5,5	80	10	10	5	M6	40	13,5	9600	12700	0,36
R20-05T4-DDB	20	5	36	58	47	6,6	82	10	10	5	M6	44	17,5	13900	21800	0,45
R25-05T4-DDB	25	5	40	62	51	6,6	95	10	10	5	M6	48	22,5	15600	27900	0,55
R25-10T3-DDB	25	10	40	62	51	6,6	115	10	16	5	M6	48	21,0	24100	36200	0,60
R32-05T5-DDB	32	5	50	80	65	9,0	95	12	10	6	M6	62	29,5	20700	43900	0,97
R32-10T4-DDB	32	10	50	80	65	9,0	138	14	16	7	M6	62	27,8	40900	63200	1,03
R32-20T2-DDB	32	20	50	80	65	9,0	138	14	16	7	M6	62	27,8	20300	26800	1,02
R40-05T5-DDB	40	5	63	93	78	9,0	109	14	10	7	M8 × 1	70	37,5	22500	54600	1,55
R40-10T4-DDB	40	10	63	93	78	9,0	150	14	16	7	M8 × 1	70	35,8	46800	82600	2,15
R40-20T2-DDB	40	20	63	93	78	9,0	150	14	16	7	M8 × 1	70	35,8	23800	36400	1,80
R50-05T5-DDB	50	5	75	110	93	11,0	112	16	10	8	M8 × 1	85	47,5	24900	69800	2,16
R50-10T4-DDB	50	10	75	110	93	11,0	164	16	16	8	M8 × 1	85	45,8	52800	106800	2,50
R50-20T3-DDB	50	20	75	110	93	11,0	196	16	16	8	M8 × 1	85	45,8	40000	76200	4,34
R63-10T6-DDB	63	10	90	125	108	11,0	205	18	16	9	M8 × 1	95	58,8	84700	210800	4,40
R63-20T4-DDB	63	20	95	135	115	13,5	270	20	25	10	M8 × 1	100	55,4	105000	250000	6,95
R80-10T6-DDB	80	10	105	145	125	13,5	205	20	16	10	M8 × 1	110	75,8	93400	269200	4,75
R80-20T4-DDB	80	20	125	165	145	13,5	280	25	25	12	M8 × 1	130	72,4	135000	322000	13,85

- Reduced axial play on request
- DIN nuts for peeled ballscrew spindles
- Mating dimensions to DIN 69051 Part 5
- Nuts with dust wipers
- Precision ground ball grooves
- Left-hand nuts on request
- Nut-housing (page 110)

Order example: **R** **63** **10** **T6** **DDB** **3850** **3972** **0,052**

2.3.6 Cylindrical single nut ZE

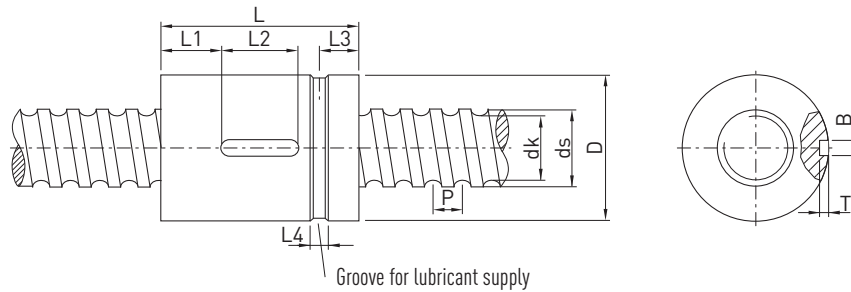

Table 2.11 Dimensions of the nut

Article number	ds h6	P	D g7	L ±0,2	L1	L2	L3	L4	T +0,1	B P9	dk	Dyn. Load C _{dyn} [N]	Stat. Load C ₀ [N]	Axial play max. [mm]	Mass [kg/pc.]
R16-05T3-ZE	16	5	28	40	12,0	16	9	4	2,4	4	13,5	9600	12700	0,02	0,10
R20-05T4-ZE	20	5	36	51	15,0	20	10	4	2,4	4	17,5	13900	21800	0,02	0,23
R25-05T4-ZE	25	5	40	60	20,0	20	12	5	2,4	4	22,5	15600	27900	0,02	0,29
R25-10T3-ZE	25	10	48	65	22,0	20	15	5	2,4	4	21,0	24100	36200	0,02	0,50
R32-05T5-ZE	32	5	48	60	20,0	20	12	5	2,4	4	29,5	20700	43900	0,02	0,38
R32-10T4-ZE	32	10	56	80	27,0	25	15	5	2,4	4	27,8	40900	63200	0,02	0,74
R32-20T2-ZE	32	20	56	80	27,0	25	15	5	2,4	4	27,8	20300	26800	0,02	0,70
R40-05T5-ZE	40	5	56	68	24,0	20	15	6	2,4	4	37,5	22500	54600	0,02	0,44
R40-10T4-ZE	40	10	62	88	31,0	25	15	6	2,4	4	35,8	46800	82600	0,02	0,85
R40-20T2-ZE	40	20	62	88	31,0	25	15	6	2,4	4	35,8	23800	36400	0,03	0,88
R50-05T5-ZE	50	5	68	69	24,0	20	15	6	2,4	4	47,5	24900	69800	0,02	0,72
R50-10T4-ZE	50	10	72	100	37,0	25	17	6	2,4	4	45,8	52800	106800	0,02	1,04
R50-20T3-ZE	50	20	72	114	44,0	25	17	6	2,4	4	45,8	40000	76200	0,03	1,10
R63-10T6-ZE	63	10	85	120	44,0	32	17	6	3,5	6	58,8	84700	210800	0,04	1,73
R63-20T4-ZE	63	20	95	135	52,0	32	17	6	3,5	6	55,4	105000	250000	0,04	3,80
R80-10T6-ZE	80	10	105	120	44,0	32	17	8	3,5	6	75,8	93400	269200	0,04	2,80
R80-20T4-ZE	80	20	125	150	52,0	45	17	8	3,5	6	72,4	135000	322000	0,05	7,80
R80-20T6-ZEH	78	20	130	182	68,5	45	19	8	4,0	0	68,2	200000	510000	0,05	11,05

- Reduced axial play on request
- Nuts with dust wiper
- Precision ground ball grooves
- Left-hand nuts on request

Order example: **R** **16** **05** **T3** **ZE** **420** **495** **0,052**

Ballscrews

Peeled Ballscrews

2.3.7 Cylindrical double nut ZD

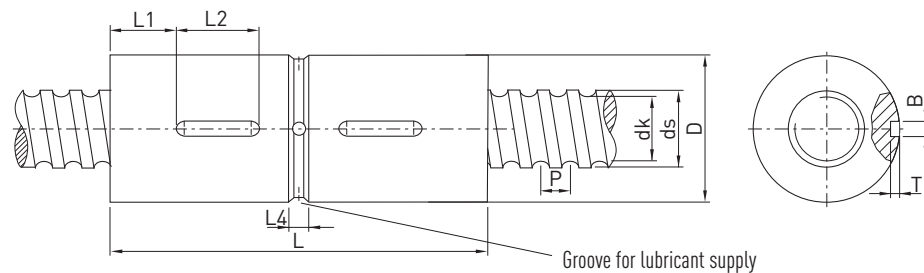

Table 2.12 Dimensions of the nut

Article number	ds h6	P	D g7	L	L1	L2	L4	T +0,1	B P9	dk	Dyn. Load C _{dyn} [N]	Stat. Load C ₀ [N]	Mass [kg/pc.]
R16-05T3-ZD	16	5	28	72	14	16	4	2,4	4	13,5	9600	12700	0,20
R20-05T4-ZD	20	5	36	86	15	20	4	2,4	4	17,5	13900	21800	0,39
R25-05T4-ZD	25	5	40	100	20	20	5	2,4	4	22,5	15600	27900	0,48
R25-10T3-ZD	25	10	48	115	20	20	5	2,4	4	21,0	24100	36200	0,80
R32-05T5-ZD	32	5	48	100	20	20	5	2,4	4	29,5	20700	43900	0,63
R32-10T4-ZD	32	10	56	136	25	25	6	2,4	4	27,8	32000	47500	1,30
R32-20T2-ZD	32	20	56	142	28	25	6	2,4	4	27,8	20300	26800	1,30
R40-05T5-ZD	40	5	56	108	20	20	6	2,4	4	37,5	22500	54600	0,78
R40-10T4-ZD	40	10	62	142	28	25	6	2,4	4	35,8	46500	82600	1,34
R40-20T2-ZD	40	20	62	146	30	25	6	2,4	4	35,8	23800	36400	1,51
R50-05T5-ZD	50	5	68	108	20	20	6	2,4	4	47,5	24900	69800	1,40
R50-10T4-ZD	50	10	72	168	35	25	8	2,4	4	45,8	52800	106800	1,72
R50-20T3-ZD	50	20	72	190	47	25	6	2,4	4	45,8	40000	76200	1,95
R63-10T6-ZD	63	10	85	208	44	32	6	3,5	6	58,8	84700	210800	2,81
R63-20T4-ZD	63	20	95	260	65	32	6	3,5	6	55,4	105000	250000	7,30
R80-10T6-ZD	80	10	105	208	44	32	6	3,5	6	75,8	93400	269200	5,50
R80-20T4-ZD	80	20	125	285	55	32	8	4,1	8	72,4	135000	322000	14,90

- Nuts with dust wiper
- Precision ground ball grooves
- Left-hand nuts on request

Order example: **R** **16** **05** **T3** **ZD** **420** **495** **0,052**

2.3.8 Cylindrical single nut SE with screw thread

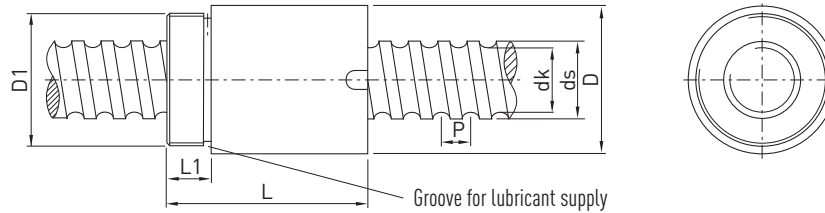

Table 2.13 Dimensions of the nut

Article number	ds h6	P	D -0,2	D1	L -0,5	L1	dk	Dyn. Load C _{dyn} [N]	Stat. Load C ₀ [N]	Axial play max. [mm]	Mass [kg/pc.]
R16-05T3-SE	16	5	36	M30 × 1,5	42	12	13,5	9600	12700	0,02	0,45
R20-05T4-SE	20	5	40	M35 × 1,5	52	12	17,5	13900	21800	0,02	0,53
R25-05T4-SE	25	5	45	M40 × 1,5	60	15	22,5	15600	27900	0,02	0,82
R25-10T3-SE	25	10	48	M45 × 1,5	70	15	21,0	24100	36200	0,02	1,00
R32-05T5-SE	32	5	52	M48 × 1,5	60	15	29,5	20700	43900	0,02	1,13
R32-10T3-SE	32	10	56	M52 × 1,5	80	15	27,8	34100	56100	0,02	1,62
R32-20T2-SE	32	20	56	M52 × 1,5	80	15	27,8	20300	26800	0,02	1,44
R40-05T5-SE	40	5	65	M60 × 1,5	68	18	37,5	22500	54600	0,02	1,63
R40-10T4-SE	40	10	65	M60 × 1,5	88	18	35,8	46800	82600	0,02	1,75
R40-20T2-SE	40	20	65	M60 × 1,5	88	18	35,8	23800	36400	0,03	1,75
R50-10T4-SE	50	10	80	M75 × 1,5	100	20	45,8	52800	106800	0,02	2,96
R50-20T3-SE	50	20	80	M75 × 1,5	114	20	45,8	40000	76200	0,03	3,15
R63-10T6-SE	63	10	95	M85 × 2	120	20	58,8	84700	210800	0,04	4,37
R63-20T3-SE	63	20	95	M85 × 2	138	20	55,4	96000	189000	0,04	4,40

- Reduced axial play on request
- Nuts with wipers
- Precision ground ball grooves
- Left-hand nuts on request

Order example: **R** **20** **05** **T4** **SE** **600** **680** **0,052**

Ballscrews

Peeled Ballscrews

2.3.9 Safety nut SEM

The safety nut consists of a ballscrew unit and a safety unit. The safety nut basically works just like a normal ballscrew nut. If the axial play increases due to wear, ball breakage, or ball loss, the thread of the safety unit comes into contact with the ballscrew. This means the nut cannot be penetrated. The normal function of the unit is guaranteed up to an axial play of 0.4 mm. The function is monitored by measuring the axial play or motor current.

Applications:

- Lifting equipment
- Clamping devices
- Lifting platforms
- Elevators

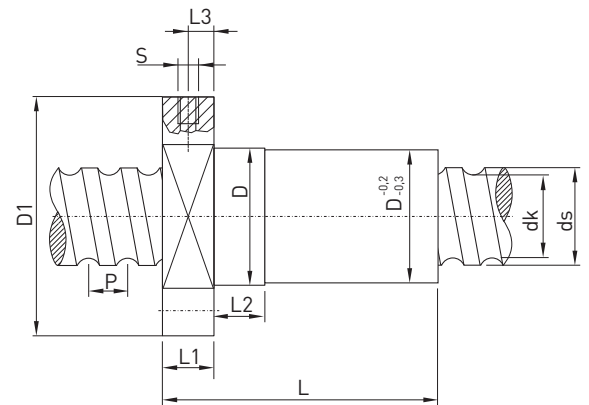
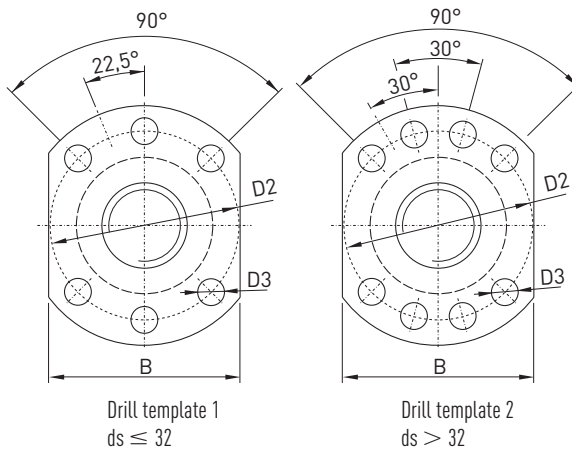
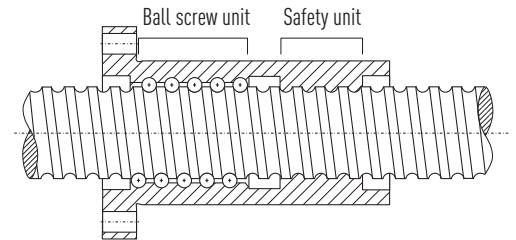
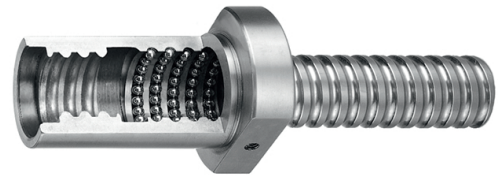

Table 2.14 Dimensions of the safety nut

Article number	ds h6	P	D g7	D1	D2	D3	Drill template	L	L1	L2	L3	S	B	dk	Dyn. Load C _{dyn} [N]	Stat. Load C ₀ [N]
R32-10T4-SEM	32	10	56	86	70	9	1	130	15	16	7,5	M6	66	27,8	40900	63200
R40-10T4-SEM	40	10	63	93	78	9	2	130	15	16	7,5	M8 × 1	70	35,8	46800	82500
R40-20T2-SEM	40	20	63	93	78	9	2	140	15	16	7,5	M8 × 1	70	35,8	23800	36400
R50-10T5-SEM	50	10	75	110	93	11	2	145	16	16	8,0	M8 × 1	85	45,8	63900	133300
R63-20T4-SEM	63	20	95	135	115	13,5	2	205	20	25	10,0	M8 × 1	100	55,4	105000	250000
R80-20T5-SEM	80	20	125	165	145	13,5	2	230	25	25	12,5	M8 × 1	130	72,4	161500	398000

The use of a safety nut alone is not a sufficient protection against unintentional lowering of a load. The valid for the application security guidelines must be followed. Additional measures, such as the monitoring of the motor current and the monitoring of the drive train are provided.

- Reduced axial play on request
- Nuts with wipers
- Precision ground ball grooves
- Left-hand nuts on request

Order example: **R** **32** **10** **T4** **SEM** **1200** **1350** **0,052**

2.3.10 Driven nut unit AME

The threaded nut is supported by an axial-contact thrust ball bearing ZKLF...2Z. The preferred type is the downgraded PE version. The bearing is preloaded as defined with a series HIR slotted precision nut. The O-shape arrangement of the two lines of balls makes for high tilting rigidity. Any axial and radial forces are borne without problems. The thick-walled stable outer ring of the bearing is screwed directly to the bearing block. No additional bearing bushing or bearing cover is used.

The oil-circuit lubrication supplies the bearing with lubricant. The ballscrew nut is lubricated via a radial bore in the spindle. For the downgraded axial-contact thrust ball bearing, only axial lubrication is possible. We're happy to develop a custom-made unit for any application to meet the respective installation requirements. A broad range of realized applications makes the perfect basis for solving your problem. Standard installation of the ZKLF bearing as shown with the extraction slot in the direction of the toothed belt wheel. Installation in reversed order is possible upon request.

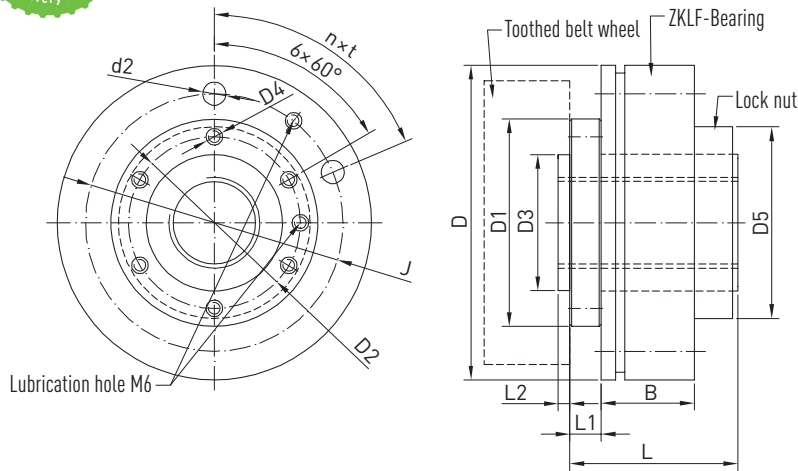

Table 2.15 Dimensions of the driven nut unit

Article number	Spindle dimensions			Nut dimensions								Bearing dimensions					Dyn. Load C_{dyn} [N]	Stat. Load C_0 [N]	r max. [r/min]
	ds h6	P	dk	D1	D2	D3 h8	D4	D5	L	L1	L2	D -0,01	J	n x t	d2	B			
R16-05T3-AME	16	5	13,5	50	40	30	M6	47	50	10	3	80	63	6 × (60°)	6,5	28	9600	12700	4000
R20-05T4-AME	20	5	17,5	63	52	40	M6	60	60	12	5	100	80	4 × (90°)	8,5	34	13900	21800	3300
R25-05T4-AME	25	5	22,5	76	60	50	M6	72	63	15	5	115	94	6 × (60°)	8,5	34	15600	27900	3000
R25-10T3-AME	25	10	21,0	76	60	50	M6	72	74	15	5	115	94	6 × (60°)	8,5	34	24100	36200	3000
R32-05T5-AME	32	5	29,5	76	62	50	M8	72	70	15	5	115	94	6 × (60°)	8,5	34	20700	43900	3000
R32-10T4-AME	32	10	27,8	76	62	50	M8	72	105	15	5	115	94	6 × (60°)	8,5	34	40900	63200	3000
R32-20T2-AME	32	20	27,8	76	62	50	M8	72	100	15	5	115	94	6 × (60°)	8,5	34	20300	26800	3000
R40-05T5-AME	40	5	37,5	90	70	60	M8	82	76	15	5	145	120	8 × (45°)	8,5	45	22500	54600	2400
R40-10T3-AME	40	10	35,8	90	70	60	M8	82	85	15	5	145	120	8 × (45°)	8,5	45	37100	61900	2400
R40-20T2-AME	40	20	35,8	90	70	60	M8	82	105	15	5	145	120	8 × (45°)	8,5	45	23800	36400	2400
R50-05T5-AME	50	5	47,5	100	84	70	M10	94	78	15	5	155	130	8 × (45°)	8,5	45	24900	69800	2200
R50-10T4-AME	50	10	45,8	100	84	70	M10	94	95	15	5	155	130	8 × (45°)	8,5	45	52800	106800	2200
R50-20T3-AME	50	20	45,8	100	84	70	M10	94	120	15	5	155	130	8 × (45°)	8,5	45	40000	76200	2200
R63-10T6-AME	63	10	58,8	130	110	90	M10	122	120	20	7	190	165	8 × (45°)	10,5	55	84700	210800	1800

- Reduced axial play on request
- Nuts with wipers
- Precision ground ball grooves
- Left-hand nuts on request

Order example: **R** **40** **05** **T5** **AME** **800** **860** **0,052**

Ballscrews

Accessory

2.4 Accessory

2.4.1 Shaft ends and bearing configuration

Table 2.16 Overview standard shaft ends for bearing series SFA, SLA

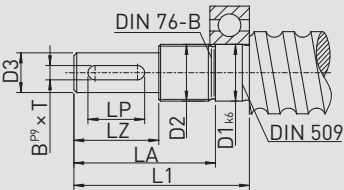
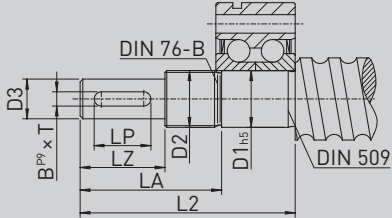
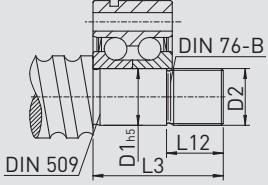
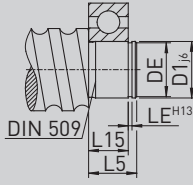
	
<p>Type S1 Bearing: deep-groove ball bearing 60.. or 62.. for bearing series SLA</p>	<p>Type S2 Bearing: ZKLF.. or ZKLN.. for bearing series SFA</p>
	
<p>Type S3 Bearing: ZKLF.. or ZKLN.. for bearing series SFA</p>	<p>Type S5 Bearing: deep-groove ball bearing 60.. for bearing series SLA</p>

Example:

Designation of a shaft end type S2 with a fitting diameter of D1=20: S2-20.

Table 2.17 Dimensions of standard shaft ends for bearing series SFA, SLA

Shaft end type	BS-Ø	D1	D2	D3	L1	L2	L3	L5	L12	L15	DE	LE	LA	LP	LZ	B × T
S_-06	12	6	M6 × 0,5	5 j6	31	37	—	8	—	6	5,7 h10	0,8	26	—	16	—
S_-10	16	10	M10 × 0,75	8 j6	39	50	30	12	12	9	9,6 h10	1,1	32	14	20	2 × 1,2
S_-12	20	12	M12 × 1	10 j6	43	58	35	13	12	10	11,5 h11	1,1	35	16	23	3 × 1,8
S_-17	25	17	M17 × 1	14 j6	60	73	43	15	20	12	16,2 h11	1,1	50	20	30	5 × 3
S_-20	25*, 32	20	M20 × 1	14 j6	62	76	46	17	20	14	19 h12	1,3	50	20	30	5 × 3
S_-25	32*, 40	25	M25 × 1,5	20 j6	83	96	46	19	20	15	23,9 h12	1,3	71	36	50	6 × 3,5
S_-30	40	30	M30 × 1,5	25 j6	95	108	48	20	22	16	28,6 h12	1,6	82	45	60	8 × 4
S_-40	50	40	M40 × 1,5	32 k6	119	135	55	22	24	18	37,5 h12	1,85	104	56	80	10 × 5
S_-50	63	50	M50 × 1,5	40 k6	142	155	55	25	24	20	47 h12	2,15	124	70	100	12 × 5
S_-60	80	60	M60 × 2	50 k6	155	177	67	28	25	22	57 h12	2,15	135	70	110	14 × 5

*depending on actual outer diameter of spindle

If none of our standard shaft ends meet your requirements, we can provide custom-made shaft ends that match your individual needs.

Table 2.18 Overview standard shaft ends for bearing series EK, BK, FK, EF, BF, FF

<p>Type E8 Bearing: 70.. for bearing series EK, FK</p>	<p>Type E9 Bearing: 72.. for bearing series BK</p>
<p>Type E10 Bearing: deep-groove ball bearing 60.. or 62.. for bearing series EF, BF, FF</p>	

Example:

Designation of a S3 shaft end with a fitting diameter of D1=10: S3-10.

Table 2.19 Dimensions of standard shaft ends for bearing series EK, BK, FK, EF, BF, FF

Shaft end type	BS-Ø	D1 h6	D4 j6	D5	D10 j6	L8	L9	L10	L16	L17	DE -0,2	LB	LC	LP	B x T	C
E_-08	12	8	6	M8 x 1	6	41	—	9	6	0,8	5,8	9	19	—	—	5,5
E_-10	16	10	8	M10 x 1	8	56	—	10	7	0,9	7,7	20	31	14	2 x 1,2	5,5
E_-12	16*	12	10	M12 x 1	10	59	—	11	8	1,15	9,6	23	34	16	3 x 1,8	5,5
E_-15	20	15	12	M15 x 1	15	70	—	13	9	1,15	14,3	23	36	16	4 x 2,5	10
E_-20	25	20	17	M20 x 1	20	92	—	19	14	1,35	19,0	30	47	20	5 x 3,0	11
E_-25	32	25	20	M25 x 1,5	25	126	115	20	15	1,35	23,9	50	70 (68) ²⁾	36	6 x 3,5	15 (9) ²⁾
E_-30	40	30	25	M30 x 1,5	30	132	132	21	16	1,75	28,6	60	85	45	8 x 4,0	9
E_-40	50	40	35 ¹⁾	M40 x 1,5	40	—	173	23	18	1,95	38,0	80	115	56	10 x 5	15

*depending on actual outer diameter of spindle, ¹⁾ tolerance k6, ²⁾ for BK 25

If none of our standard shaft ends meet your requirements, we can provide custom-made shaft ends that match your individual needs.

Ballscrews

Accessory

Table 2.20 Overview of bearing type and respective shaft end for SLA, SFA

BS-∅	Fixed side		Supported side	
	Pedestal bearing	Shaft end	Pedestal bearing	Shaft end
12	SFA-06	S2-06 / S3-06	SLA-06	S1-06 / S5-06
16	SFA-10	S2-10 / S3-10	SLA-10	S1-10 / S5-10
20	SFA-12	S2-12 / S3-12	SLA-12	S1-12 / S5-12
25	SFA-17	S2-17 / S3-17	SLA-17	S1-17 / S5-17
32	SFA-20	S2-20 / S3-20	SLA-20	S1-20 / S5-20
40	SFA-30	S2-30 / S3-30	SLA-30	S1-30 / S5-30
50	SFA-40	S2-40 / S3-40	SLA-40	S1-40 / S5-40

Table 2.21 Overview of bearing type and respective shaft end for EK, BK, FK, EF, BF, FF

BS-∅	Fixed side				Supported side			
	Pedestal bearing	Shaft end	Flange bearing	Shaft end	Pedestal bearing	Shaft end	Flange bearing	Shaft end
12	EK-08	E8-08	FK08	E8-08	EF08	E10-08	FF10	E10-10
16	EK10	E8-10	FK10	E8-10	EF10	E10-10	FF10	E10-10
16	EK-12	E8-12	FK12	E8-12	EF12	E10-12	FF12	E10-12
20	EK-15	E8-15	FK15	E8-15	EF15	E10-15	FF15	E10-15
25	EK-20	E8-20	FK20	E8-20	EF20	E10-20	FF20	E10-20
32	BK-25	E9-25	FK25	E8-25	BF25	E10-25	FF25	E10-25
40	BK-30	E9-30	FK30	E8-30	BF30	E10-30	FF30	E10-30
50	BK-40	E9-40	—	—	BF40	E10-40	—	E10-40

*depending on actual outer diameter of spindle

2.4.2 Bearing series SFA / SLA

2.4.2.1 Fixed bearing SFA

The stage height of the fixed bearing is matched to the supported bearing SLA (page 109) and to the nut housing (page 110). The pillow block can be fixed from the top (S1) and bottom (S2).

The stop edges on both sides facilitate alignment of the unit. The fixed bearing is pinned using two taper pins or cylindrical pins. The correct end machining for the fixed bearing is type S2-xx/S3-xx (page 104).

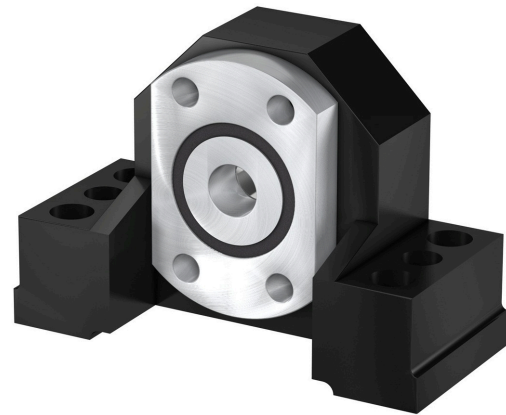
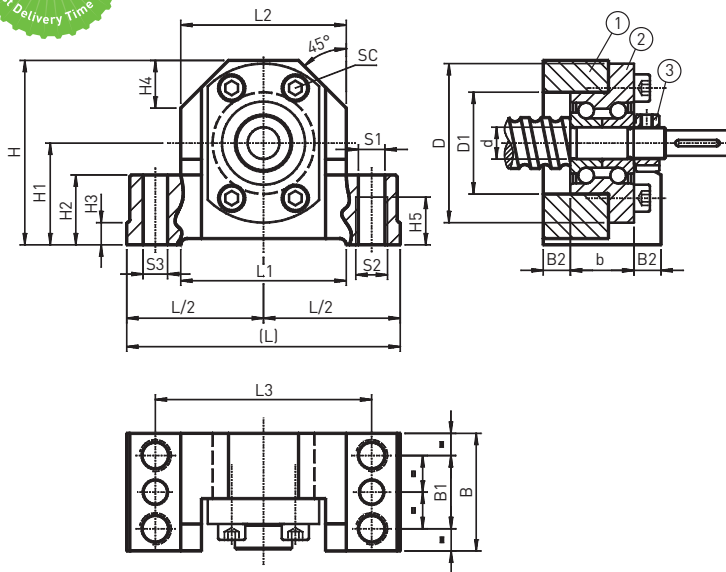

Table 2.22 Dimensions of the bearing unit

Article number	Spindle Ø	L	L/2 js9	L1	L2	L3	H	H1 JS7	H2	H3	H4	H5	d	D	D1	b
SFA06	12	62	31	34	38	50	41	22	13	5	11	9	6	30	19	12
SFA10	16	86	43	52	52	68	58	32	22	7	15	15	10	50	32	20

Table 2.23 Dimensions of the bearing unit

Article number	Spindle Ø	B	B1	B2	S1 H12	S2	S3	Lock nut	SC ISO 4762-10.9
SFA06	12	32	16	10	5,3	M6	3,7	HIR 06	4 x M3 x 12
SFA10	16	37	23	8,5	8,4	M10	7,7	HIR 10	4 x M5 x 20

Table 2.24 Technical data of the bearing

Article number	Bearing	Static Load C_0 axial [N]	Dynamic Load C_{dyn} axial [N]	r max. [r/min]
SFA06	ZKLFA0630.2Z	6100	4900	14000
SFA10	ZKLFA1050.2RS	8500	6900	6800

(1) steel pillow block, (2) bearing, (3) lock nut

Ballscrews

Accessory

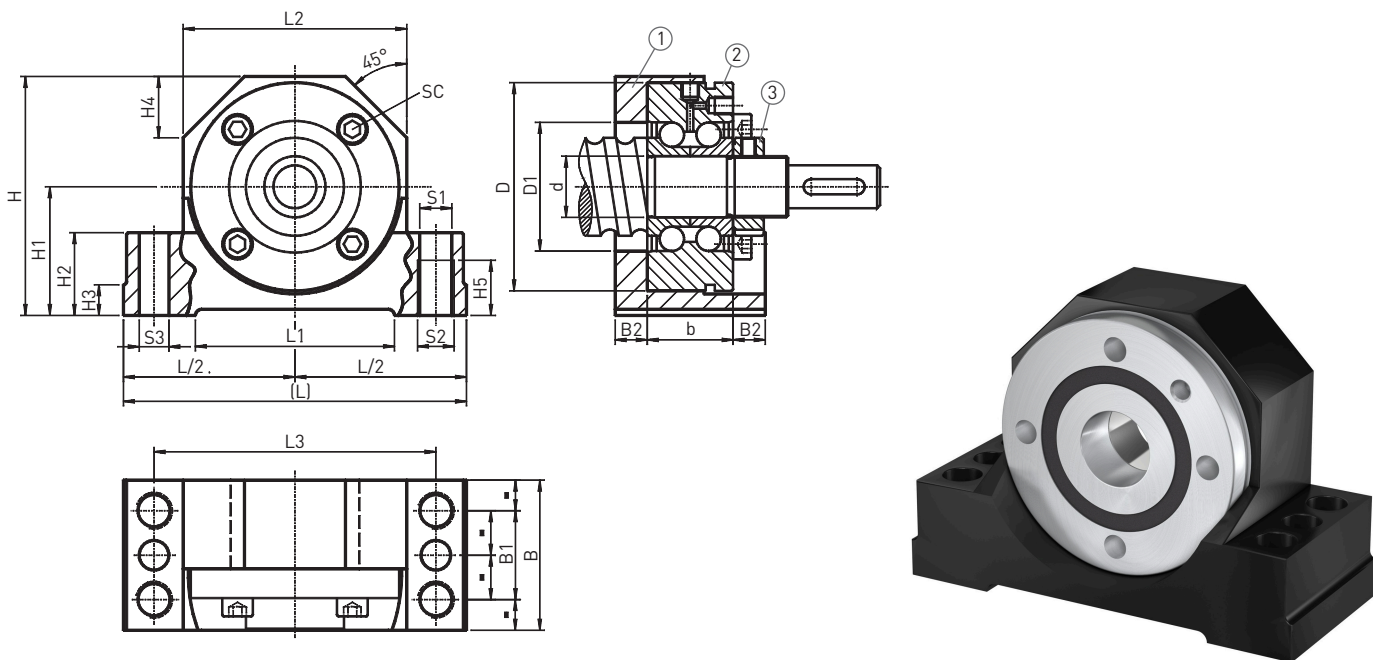

Table 2.25 Dimensions of the bearing unit

Article number	Spindle Ø	L	L/2 js9	L1	L2	L3	H	H1 JS7	H2	H3	H4	H5	d	D	D1	b
SFA12	20	94	47	52	60	77	64	34	22	7	17	15	12	55	32	25
SFA17	25	108	54	65	66	88	72	39	27	10	19	18	17	62	36	25
SFA20	32	112	56	65	73	92	78	42	27	10	20	18	20	68	42	28
SFA30	40	126	63	82	84	105	92	50	32	13	23	21	30	80	52	28
SFA40	50	146	73	82	104	125	112	60	32	13	30	21	40	100	66	34

Table 2.26 Dimensions of the bearing unit

Article number	Spindle Ø	B	B1	B2	S1 H12	S2	S3	Lock nut	SC ISO 4762-10.9
SFA12	20	42	25	8,5	8,4	M10	7,7	HIR 12	3 x M6 x 35
SFA17	25	46	29	10,5	10,5	M12	9,7	HIR 17	3 x M6 x 35
SFA20	32	49	29	10,5	10,5	M12	9,7	HIR 20 x 1	4 x M6 x 40
SFA30	40	53	32	12,5	12,6	M14	9,7	HIR 30	6 x M6 x 40
SFA40	50	59	34	12,5	12,6	M14	9,7	HIR 40	4 x M8 x 50

Table 2.27 Technical data of the bearing

Article number	Bearing	Static Load C_0 axial [N]	Dynamic Load C_{dyn} axial [N]	r max. [r/min]
SFA-12	ZKLF1255.2RS	24700	17000	3800
SFA-17	ZKLF1762.2RS	31000	18800	3300
SFA-20	ZKLF2068.2RS	47000	26000	3000
SFA-30	ZKLF3080.2RS	64000	29000	2200
SFA-40	ZKLF40100.2RS	101000	43000	1800

(1) steel pillow block, (2) bearing, (3) locknut

2.4.2.2 Supported bearing SLA

The stage height of the supported bearing is matched to the fixed bearing SFA (page 107) and to the nut housing GFD (page 110). The pillow block can be fixed from the top (S1) and bottom (S2).

The stop edge facilitates alignment of the unit. The correct end machining for the supported bearing is type S5-xx (page 104).

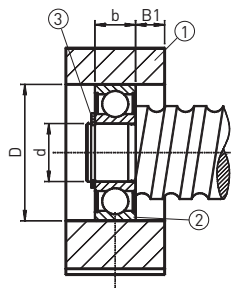
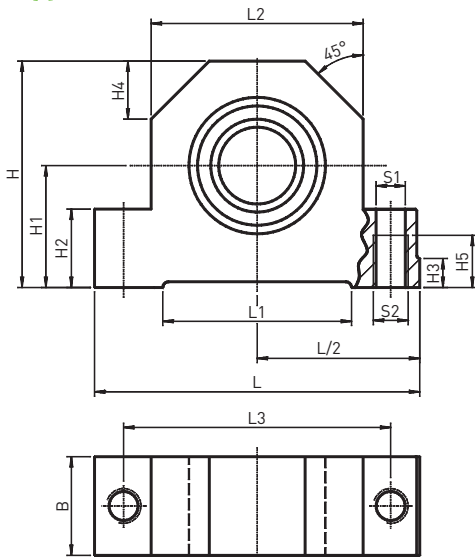

Table 2.28 Dimensions of the bearing unit

Article number	Spindle Ø	L	L/2 js9	L1	L2	L3	H	H1 JS7	H2	H3	H4	H5	b
SLA06	12	62	31	34	38	50	41	22	13	5	11	9	6
SLA10	16	86	86	52	52	68	58	32	22	7	15	15	9
SLA12	20	94	47	52	60	77	64	34	22	7	17	15	10
SLA17	25	108	54	65	66	88	72	39	27	10	19	18	12
SLA20	32	112	56	65	73	92	78	42	27	10	20	18	14
SLA30	40	126	63	82	84	105	92	50	32	13	23	21	16
SLA40	50	146	73	82	104	125	112	60	32	13	30	21	18

Table 2.29 Dimensions of the bearing unit

Article number	Spindle Ø	B	B1	S1 H12	S2	d	D H6	Circlip DIN 471	Deep-groove ball bearing DIN 623
SLA06	12	15	4,5	5,3	M6	6	19	6 × 0,7	626.2RS
SLA10	16	24	7,5	8,4	M10	10	30	10 × 1	6200.2RS
SLA12	20	26	8	8,4	M10	12	32	12 × 1	6201.2RS
SLA17	25	28	8	10,5	M12	17	40	17 × 1	6203.2RS
SLA20	32	34	10	10,5	M12	20	47	20 × 1,2	6204.2RS
SLA30	40	38	11	12,6	M14	30	62	30 × 1,5	6206.2RS
SLA40	50	44	13	12,6	M14	40	80	40 × 1,75	6208.2RS

Ballscrews

Accessory

2.4.3 Housing for flanged nuts (DIN 69051 Part 5)

The nut housing is suitable for installation of flanged nuts DEB (page 97), DDB (page 98) and FSCDIN (page 94). The stage height of the housing is matched to the fixed bearing SFA (page 107) and the supported bearing SLA (page 109).

The housing unscrews from the top (S1) and bottom (S2) and is pinned using two taper pins or cylindrical pins. Two screws of property class 8.8 must be provided to secure the housing.

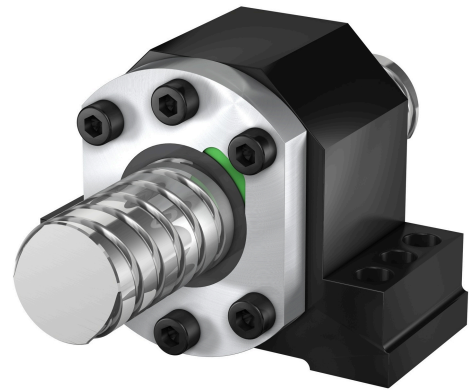
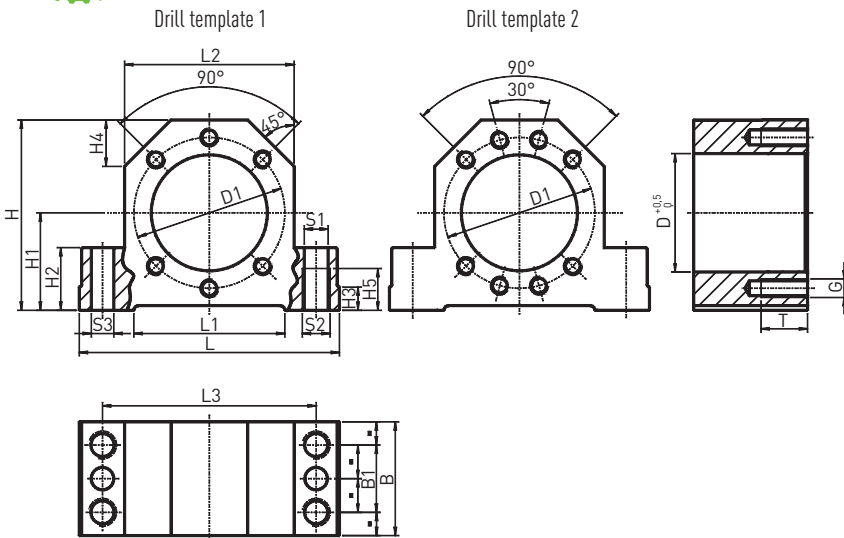

Table 2.30 Dimensions of the nut housing

Article number	Spindle \varnothing	L	L1	L2	L3	H	H1 JS7	H2	H3	H4	H5
GFD16	16	86	52	52	68	58	32	22	7	15	15
GFD20	20	94	52	60	77	64	34	22	7	17	15
GFD25	25	108	65	66	88	72	39	27	10	19	18
GFD32	32	112	65	72	92	82	42	27	10	19	18
GFD40	40	126	82	84	105	97	50	32	13	23	21
GFD50	50	146	82	104	125	115	60	32	13	30	21

Table 2.31 Dimensions of the nut housing

Article number	Spindle \varnothing	D	D1	B	B1	S1 H12	S2	S3	Drill template	G	T
GFD16	16	28	38	37	23	8,4	M10	7,7	1	M5	12
GFD20	20	36	47	42	25	8,4	M10	7,7	1	M6	15
GFD25	25	40	51	46	29	10,5	M12	9,7	1	M6	15
GFD32	32	50	65	49	29	10,5	M12	9,7	1	M8	20
GFD40	40	63	78	53	32	12,6	M14	9,7	2	M8	20
GFD50	50	75	93	59	34	12,6	M14	9,7	2	M10	25

2.4.4 Bearing series EK / EF

2.4.4.1 Fixed Bearing EK

The corresponding supported bearing is the bearing series EF (page 112). The correct end machining for the fixed bearing is type E8-xx (page 105).

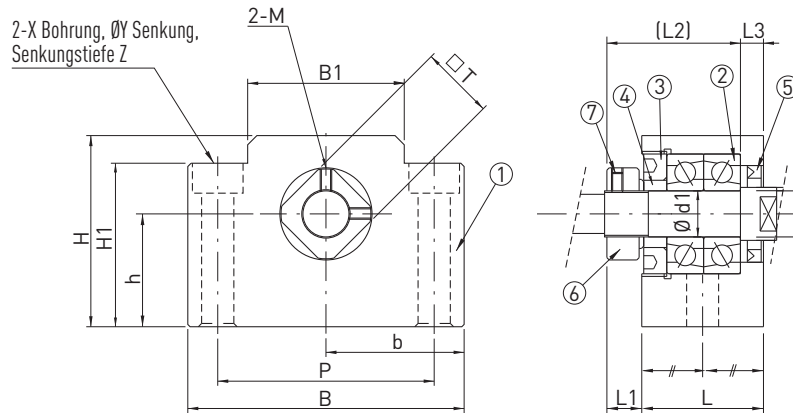

Table 2.32 Dimensions of the bearing unit

Article number	Spindle Ø	d1	L	L1	L2	L3	B	H	b ±0,02	h ±0,02	B1	H1	P	X	Y	Z	M	T
EK08	12	8	23	7	26	4	52	32	26	17	25	26	38	6,6	11	12	M3	14

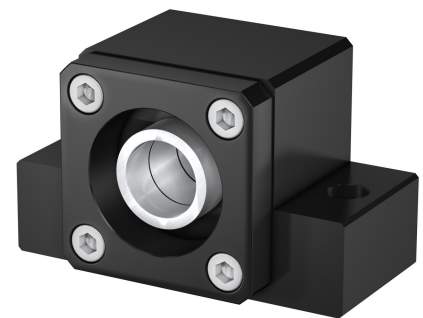
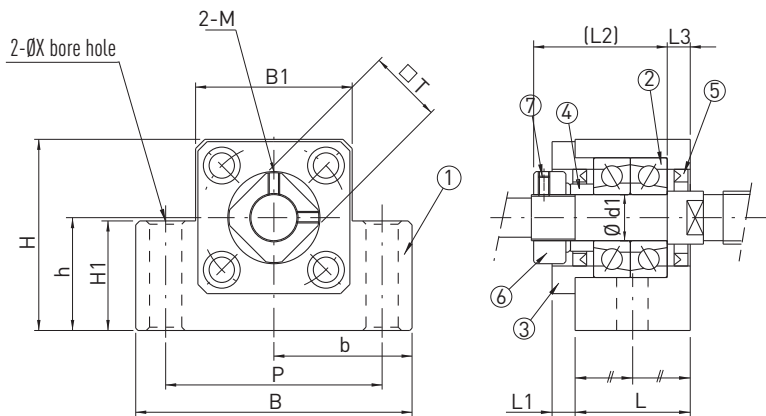

Table 2.33 Dimensions of the bearing unit

Article number	Spindle Ø	d1	L	L1	L2	L3	B	H	b ±0,02	h ±0,02	B1	H1	P	X	Y	Z	M	T
EK-10	16	10	24	6	29,5	6	70	43	35,0	25	36	24	52	9	—	—	M3	16
EK-12	16*	12	24	6	29,5	6	70	43	35,0	25	36	24	52	9	—	—	M4	19
EK-15	20	15	25	6	36,	5	80	49	40,0	30	41	25	60	11	—	—	M4	22
EK-20	25	20	42	10	50,	10	95	58	47,5	30	56	25	75	11	—	—	M4	30

(1) housing, (2) bearing, (3) cover plate, (4) supporting ring, (5) seal, (6) lock nut, (7) allen set screw
*depending on actual outer diameter of spindle.

Ballscrews

Accessory

Table 2.34 **Technical data of the bearing**

Article number	Bearing	Static Load C_0 [N]	Dynamic Load C_{dyn} [N]	Max. axial load [N]	r max. [r/min]
EK08	708	4800	2800	1100	40000
EK10	7000A P0	8800	5200	2000	24000
EK12	7001A P0	9400	6000	2200	22000
EK15	7002A P0	10000	6900	2400	19000
EK20	7204B P0	21600	15200	6800	9500

2.4.4.2 Supported bearing EF

The corresponding bearing is the bearing series EK (page 111). The correct end machining for the fixed bearing is type E10-xx (page 105).

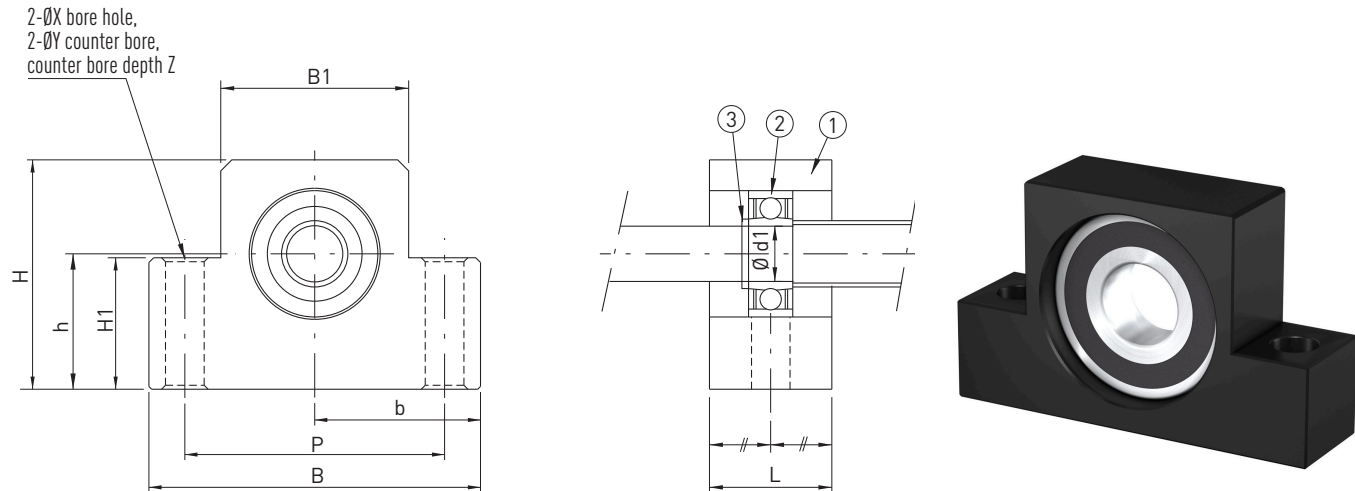

Table 2.35 **Dimensions of the bearing unit**

Article number	Spindle \varnothing	d1	L	B	H	b $\pm 0,02$	h $\pm 0,02$	B1	H1	P	X	Y	Z	Bearing	Circlip
EF-08	12	6	14	52	32	26,0	17	25	26	38	6,6	11	12	606ZZ	S 06
EF-10	16	8	20	70	43	35,0	25	36	24	52	9,0	—	—	608ZZ	S 08
EF-12	16*	10	20	70	43	35,0	25	36	24	52	9,0	—	—	6000ZZ	S 10
EF-15	20	15	20	80	49	40,0	30	41	25	60	9,0	—	—	6002ZZ	S 15
EF-20	25	20	26	95	58	47,5	30	56	25	75	11,0	—	—	6204ZZ	S 20

(1) housing, (2) bearing, (3) circlip

* depending on actual outer diameter of spindle

2.4.5 Bearing series BK / BF

2.4.5.1 Fixed bearing BK

The corresponding bearing is the bearing series BF (page 114). The correct end machining for the fixed bearing is type E9-xx (page 105).

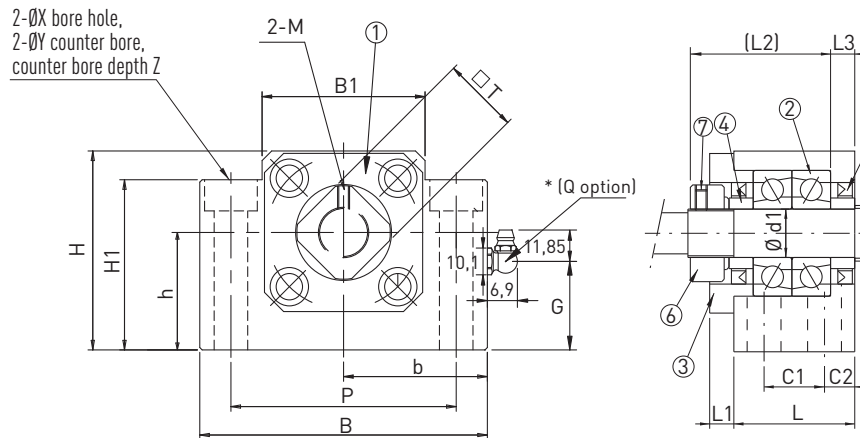

Table 2.36 Dimensions of the bearing unit

Article number	Spindle Ø	d1	L	L1	L2	L3	B	H	b ±0,02	h ±0,02
BK25	32	25	42	12	54	9	106	80	53	48
BK30	40	30	45	14	61	9	128	89	64	51
BK40	50	40	61	18	76	15	160	110	80	60

Table 2.37 Dimensions of the bearing unit

Article number	Spindle Ø	B1	H1	P	C1	C2	X	Y	Z	M	T	G	Q
BK25	32	64	70	85	22	10	11	17	11,0	M5	35	39,5	M6
BK30	40	76	78	102	23	11	14	20	13,0	M6	40	41,5	M6
BK40	50	100	90	130	33	14	18	26	17,5	M8	50	42,5	M6

Table 2.38 Technical data of the bearing

Article number	Bearing	Static Load C_0 [N]	Dynamic Load C_{dyn} [N]	Max. axial load [N]	r max. [r/min]
BK25	7205A P0	26300	20500	7000	12000
BK30	7206B P0	33500	27000	10600	7100
BK40	7208B P0	52000	46100	18000	5300

(1) housing, (2) bearing, (3) cover plate, (4) supporting ring, (5) seal, (6) lock nut, (7) allen set screw

Ballscrews

Accessory

2.4.5.2 Supported bearing BF

The stage height of the supported bearing is matched to the fixed bearing BK (page 113). The correct end machining for the supported bearing is type E10-xx (page 105).

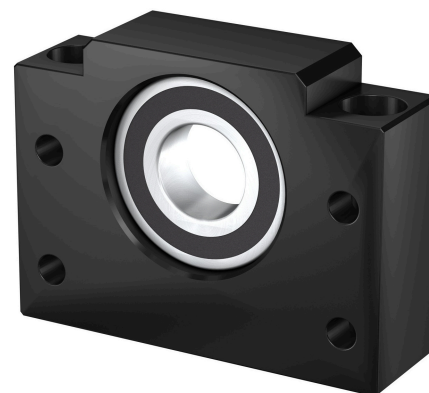
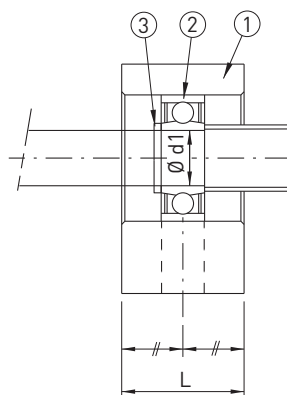
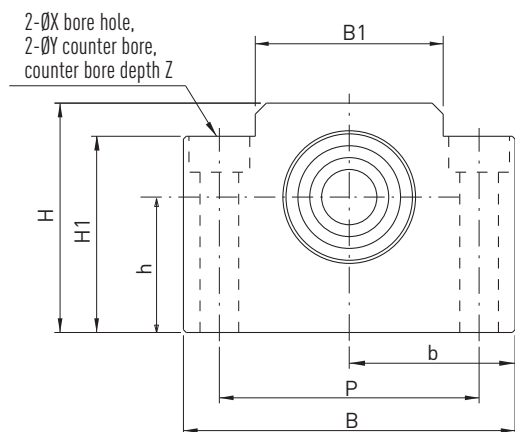

Table 2.39 Dimensions of the bearing unit

Article number	Spindle \varnothing	d1	L	B	H	b $\pm 0,02$	h $\pm 0,02$	B1	H1	P	X	Y	Z	Bearing	Circlip
BF25	32	25	30	106	80	53	48	64	70	85	11	17	11,0	6205ZZ	S 25
BF30	40	30	32	128	89	64	51	76	78	102	14	20	12,0	6206ZZ	S 30
BF40	50	40	37	160	110	80	60	100	90	130	18	26	17,5	6208ZZ	S 40

(1) housing, (2) bearing, (3) circlip

2.4.6 Bearing series FK / FF

2.4.6.1 Fixed bearing FK

The corresponding supported bearing is the bearing series FF (page 116). The correct end machining for the fixed bearing is type E8-xx (page 105).

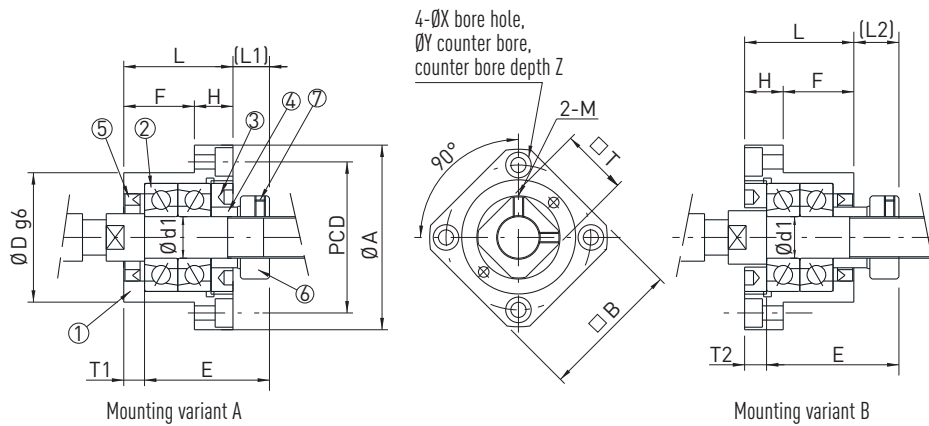

Table 2.40 Dimensions of the bearing unit

Article number	Spindle Ø	d1	L	H	F	E	D g6	A	PCD	B	Mounting variant A		Mounting variant B		X	Y	Z	M	T	G	Q
											L1	T1	L2	T2							
FK08	12	8	23	9	14	26	28	43	35	35	7	4	10	7	3,4	6,5	4	M3	14	—	—

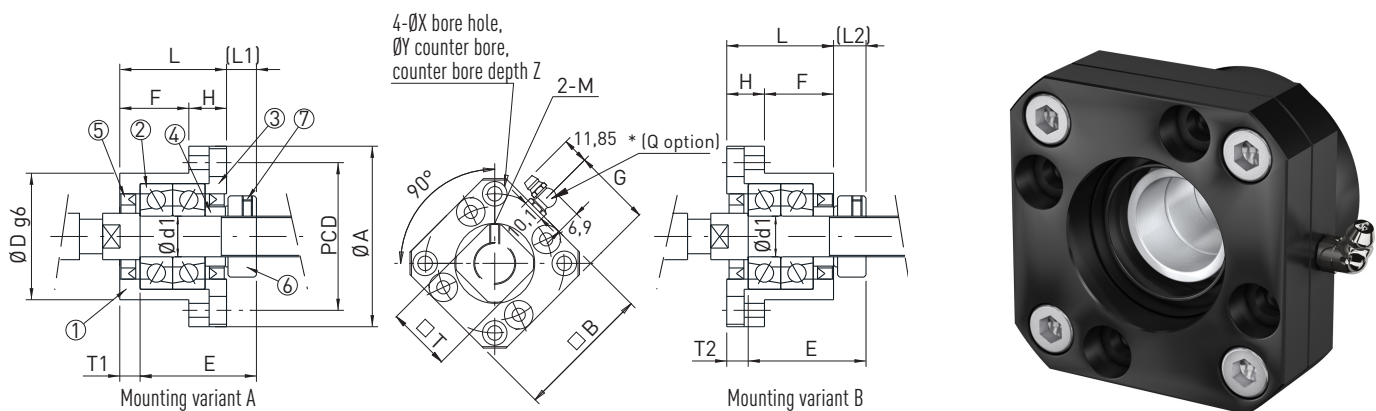

Table 2.41 Dimensions of the bearing unit

Article number	Spindle Ø	d1	L	H	F	E	D g6	A	PCD	B	Mounting variant A		Mounting variant B		X	Y	Z	M	T	G	Q
											L1	T1	L2	T2							
FK10	16	10	27	10	17	29,5	34	52	42	42	7,5	5	8,5	6	4,5	8,0	4	M3	16	—	—
FK12	16*	12	27	10	17	29,5	36	54	44	44	7,5	5	8,5	6	4,5	8,0	4	M4	19	—	—
FK15	20	15	32	15	17	36,0	40	63	50	52	10,0	6	12,0	8	5,5	9,5	6	M4	22	—	—
FK20	25	20	52	22	30	50,0	57	85	70	68	8,0	10	12,0	14	6,6	11,0	10	M4	30	34	M6
FK25	32	25	57	27	30	60,0	63	98	80	79	13,0	10	20,0	17	9,0	15,0	13	M5	35	39	M6
FK30	40	30	62	30	32	61,0	75	117	98	93	11,0	12	17,0	18	11,0	17,5	15	M6	40	46	M6

(1) housing, (2) bearing, (3) cover plate, (4) supporting ring, (5) seal, (6) lock nut, (7) allen set screw

*depending to the effective spindle-diameter.

Ballscrews

Accessory

Table 2.42 **Technical data of the bearing**

Article number	Bearing	Static Load C_0 [N]	Dynamic Load C_{dyn} [N]	Max. axial load [N]	r max. [r/min]
FK08	708	4800	2800	1000	40000
FK10	7000A P0	8800	5200	1900	24000
FK12	7001A P0	9400	6000	2200	22000
FK15	7002A P0	10000	6900	2400	19000
FK20	7204B P0	21600	15300	6800	9500
FK25	7205B P0	24000	19000	8100	8500
FK30	7206B P0	33500	27000	10600	7100

2.4.6.2 Supported bearing FF

The corresponding fixed bearing is the bearing series FK (page 115). The correct end machining for the supported bearing is type E10-xx (page 105).

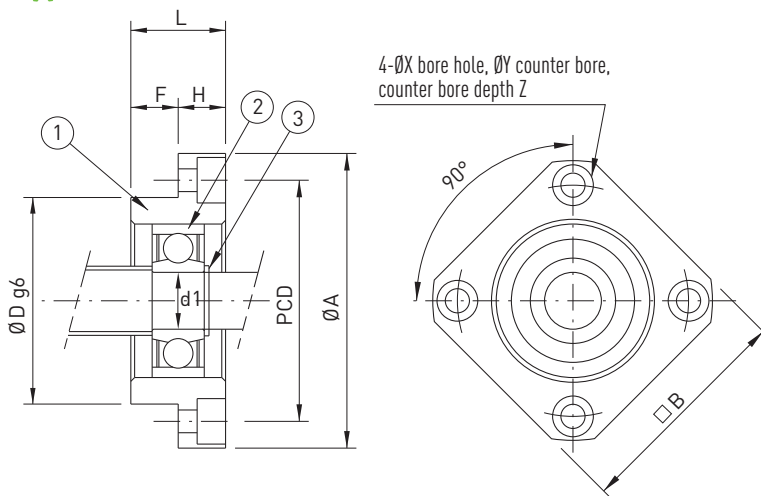

Table 2.43 **Dimensions of the bearing unit**

Article number	Spindle Ø	d1	L	H	F	D g6	A	PCD	B	X	Y	Z	Bearing	Circlip
FF10	16	8	12	7	5	28	43	35	35	3,4	6,5	4,0	608ZZ	S 08
FF12	16*	10	15	7	8	34	52	42	42	4,5	8,0	4,0	6000ZZ	S 10
FF15	20	15	17	9	8	40	63	50	52	5,5	9,5	5,5	6002ZZ	S 15
FF20	25	20	20	11	9	57	85	70	68	6,6	11,0	6,5	6204ZZ	S 20
FF25	32	25	24	14	10	63	98	80	79	9,0	14,0	8,5	6205ZZ	S 25
FF30	40	30	27	18	9	75	117	95	93	11,0	17,0	11,0	6206ZZ	S 30

(1) housing, (2) bearing, (3) circlip

*depending to the effective spindle-diameter.

3.1 Linear Axes KK

3.1.1 Product overview linear axes KK

HIWIN linear axes KK are compact positioning axes. The advance is generated by a ballscrew, which is mounted in a drive flange ready to use by the motor. Movement is guided by a linear guideway. Various equipment versions and sizes adapt the linear axes to very different tasks and industries.

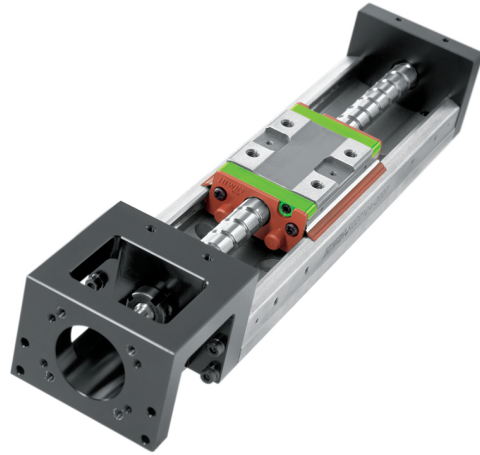

3.1.2 Construction of the linear axes KK

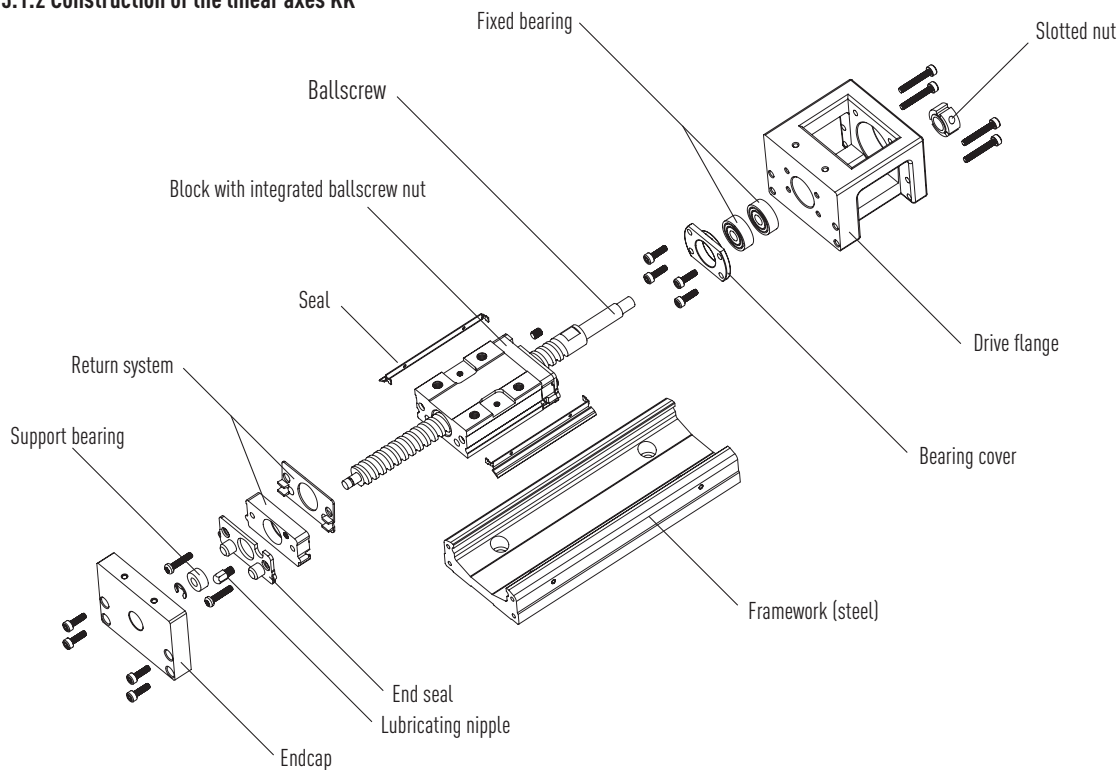

3.1.3 Advantages of linear axes KK

- Module for positioning tasks: Linear axes KK with ballscrew from HIWIN can be used universally and are suitable as ready-to-mount stages for many different positioning tasks.
- Lean and light: Thanks to their compact and lean construction as well as light mass, linear axes KK can also be integrated into applications with little space.
- Adaptable and sturdy: Linear axes KK can be equipped with a bellows cover or aluminum cover depending on the ambient requirements.
- Framework and block made of steel with surface corrosion protection.

Positioning Systems

Linear Axes KK

3.1.4 Order key for linear axes KK

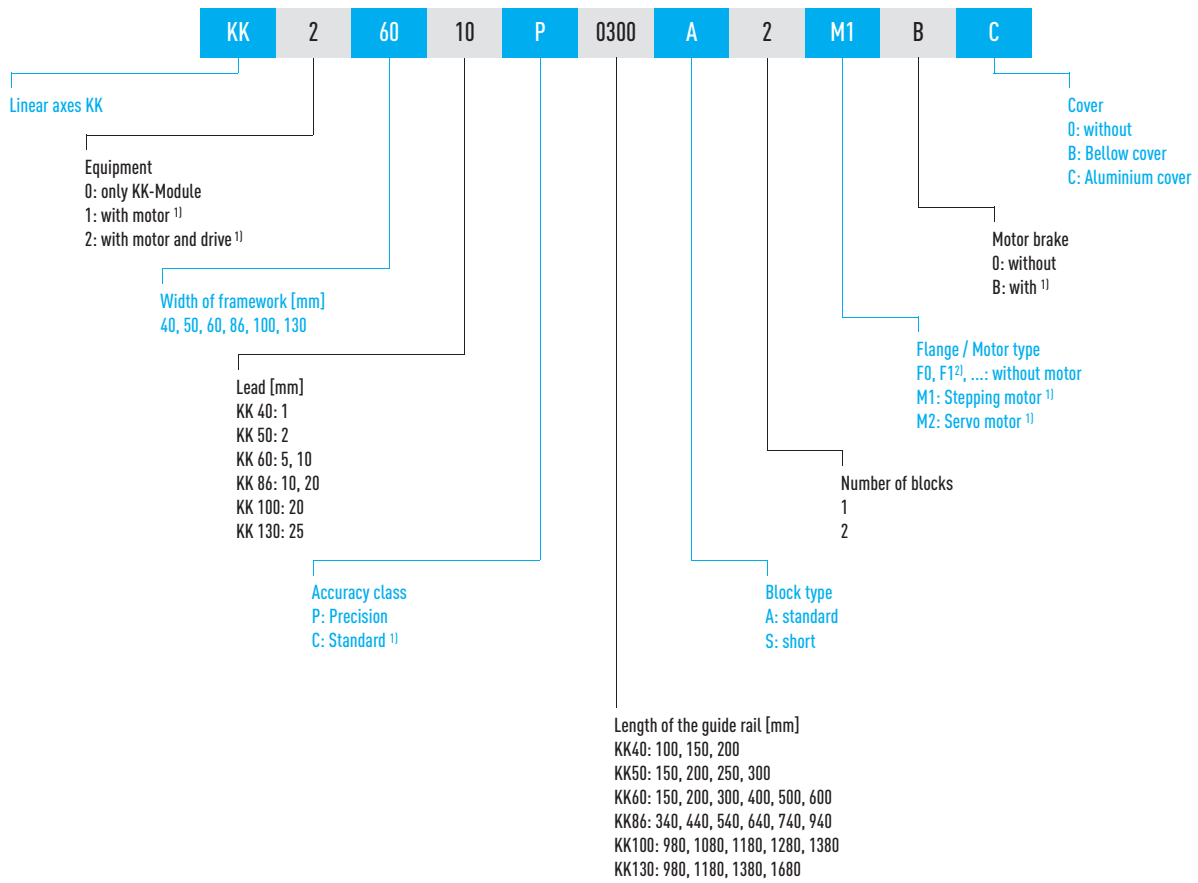

¹⁾ On request

²⁾ By default, an adapter flange F1, F2,... will be delivered unassembled.

3.1.5 Technical data of linear axes KK

Table 3.44 Technical data of linear axes KK

Model	Lead [mm]	L1 [mm]	V _{max} [mm/s]	Accuracy [mm]	Repeatability [mm]	Guideway parallelism [mm]	Starting torque [Nmm]
KK4001P0100	1	159	190	0,020	± 0,003	0,010	12
KK4001P0150	1	209	190	0,020	± 0,003	0,010	12
KK4001P0200	1	259	190	0,020	± 0,003	0,010	12
KK5002P0150	2	220	270	0,020	± 0,003	0,010	40
KK5002P0200	2	270	270	0,020	± 0,003	0,010	40
KK5002P0250	2	320	270	0,020	± 0,003	0,010	40
KK5002P0300	2	370	270	0,020	± 0,003	0,010	150
KK6005P0150	5	220	550	0,020	± 0,003	0,010	150
KK6005P0200	5	270	550	0,020	± 0,003	0,010	150
KK6005P0300	5	370	550	0,020	± 0,003	0,010	150
KK6005P0400	5	470	550	0,020	± 0,003	0,010	150
KK6005P0500	5	570	550	0,020	± 0,003	0,010	150
KK6005P0600	5	670	340	0,025	± 0,003	0,015	150
KK6010P0150	10	220	1100	0,020	± 0,003	0,010	150
KK6010P0200	10	270	1100	0,020	± 0,003	0,010	150
KK6010P0300	10	370	1100	0,020	± 0,003	0,010	150
KK6010P0400	10	470	1100	0,020	± 0,003	0,010	150
KK6010P0500	10	570	1100	0,020	± 0,003	0,010	150
KK6010P0600	10	670	670	0,025	± 0,003	0,015	150
KK8610P0340	10	440	740	0,025	± 0,003	0,015	150
KK8610P0440	10	540	740	0,025	± 0,003	0,015	150
KK8610P0540	10	640	740	0,025	± 0,003	0,015	150
KK8610P0640	10	740	740	0,025	± 0,003	0,015	150
KK8610P0740	10	840	740	0,030	± 0,003	0,020	170
KK8610P0940	10	1040	610	0,040	± 0,003	0,030	250
KK8620P0340	20	440	1480	0,025	± 0,003	0,015	150
KK8620P0440	20	540	1480	0,025	± 0,003	0,015	150
KK8620P0540	20	640	1480	0,025	± 0,003	0,015	150
KK8620P0640	20	740	1480	0,025	± 0,003	0,015	150
KK8620P0740	20	840	1480	0,030	± 0,003	0,020	170
KK8620P0940	20	1040	1220	0,040	± 0,003	0,030	250
KK10020P0980	20	1089	1120	0,035	± 0,005	0,025	170
KK10020P1080	20	1189	980	0,035	± 0,005	0,025	170
KK10020P1180	20	1289	750	0,040	± 0,005	0,030	200
KK10020P1280	20	1389	630	0,045	± 0,005	0,035	230
KK10020P1380	20	1489	530	0,050	± 0,005	0,040	250
KK13025P0980	25	1098	1120	0,035	± 0,005	0,025	250
KK13025P1180	25	1298	1120	0,040	± 0,005	0,030	250
KK13025P1380	25	1498	830	0,040	± 0,005	0,030	250
KK13025P1680	25	1798	550	0,050	± 0,007	0,040	270

Reference Side

When observed from the motor flange, the reference side is located on the left side of the linear module.

Positioning Systems

Linear Axes KK

3.1.6 Load capacities of linear axes KK

Display of static moments affecting the linear axes KK.

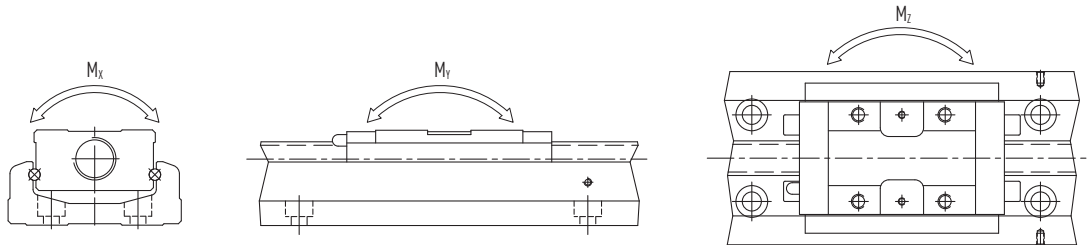

Table 3.45 Load capacity of linear axes KK: Guideway, standard block

Model	C_{dyn} [N]	C_0 [N]	Block A1			Block A2		
			M_x [Nm]	M_y [Nm]	M_z [Nm]	M_x [Nm]	M_y [Nm]	M_z [Nm]
KK40	3920	6468	33	33	81	182	182	162
KK50	8007	12916	116	116	222	545	545	444
KK60	13230	21462	152	152	419	760	760	838
KK86	31458	50764	622	622	1507	3050	3050	3014
KK100	39200	63406	960	960	2205	4746	4763	4410
KK130	48101	84829	1536	1536	3885	7350	7350	7770

Table 3.46 Load capacity of linear axes KK: Guideway, short block

Model	C_{dyn} [N]	C_0 [N]	Block S1			Block S2		
			M_x	M_y	M_z	M_z	M_y	M_x
KK60	7173	11574	72	72	241	482	367	367

Table 3.47 Load capacity of linear axes KK: Ballscrew and fixed bearing

Model	Spindle			Fixed side	
	\varnothing [mm]	C_{dyn} [N]	C_0 [N]	$C_{0 Axial}$ [N]	$F_{max Axial}$ [N]
KK4001Pxxxx	8	735	1538	1910	750
KK5002Pxxxx	8	2136	3489	1910	1500
KK6005Pxxxx	12	3744	6243	4480	3120
KK6010Pxxxx	12	2410	3743	4480	1870
KK8610Pxxxx	15	7144	12642	9240	6320
KK8620Pxxxx	15	4645	7655	9240	3825
KK10020Pxxxx	20	7046	12544	10600	6270
KK13025Pxxxx	25	7897	15931	18485	7950

3.1.7 Linear axes KK40 without cover

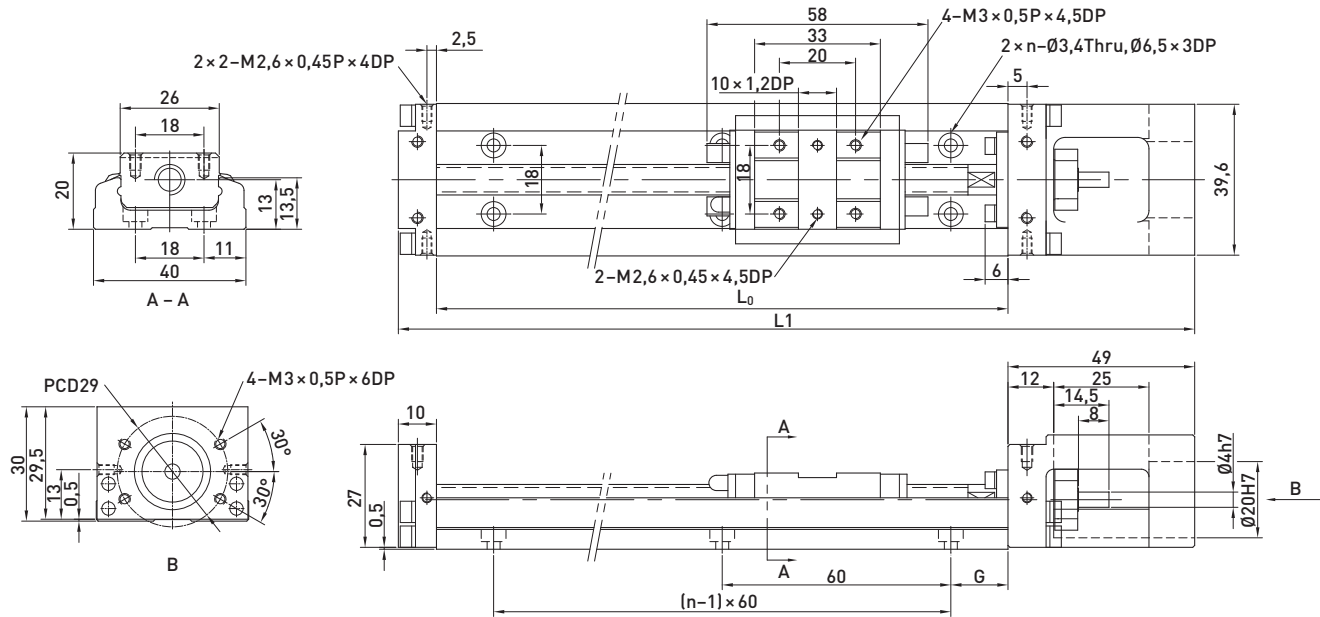

Table 3.48 Dimensions and mass of linear axes KK40 without cover

Model	Lead [mm]	L0 [mm]	L1 [mm]	Maximum stroke [mm]		G [mm]	K [mm]	n	m	Mass [kg]	
				Block A1	Block A2					Block A1	Block A2
KK4001P0100	1	100	159	36	-	20	-	2	-	0,48	-
KK4001P0150	1	150	209	86	34	15	-	3	-	0,60	0,67
KK4001P0200	1	200	259	136	84	40	-	3	-	0,72	0,79

Positioning Systems

Linear Axes KK

3.1.8 Linear axes KK40 with aluminium cover

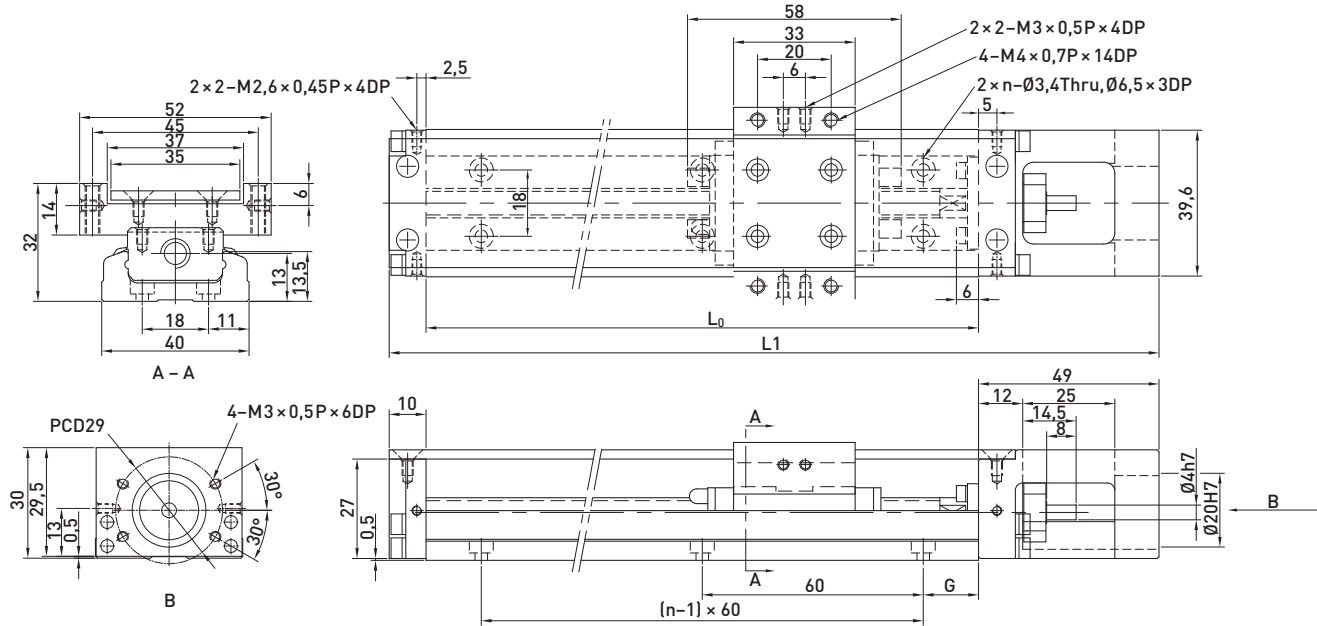
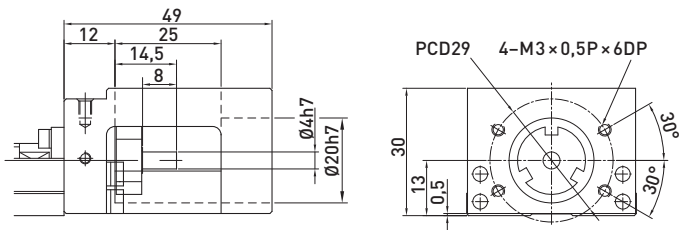

Table 3.49 Dimensions and mass of linear axes KK40 with aluminium cover

Model	Lead [mm]	L0 [mm]	L1 [mm]	Maximum stroke [mm]		G [mm]	K [mm]	n	m	Mass [kg]	
				Block A1	Block A2					Block A1	Block A2
KK4001P0100	1	100	159	36	-	20	-	2	-	0,55	-
KK4001P0150	1	150	209	86	34	15	-	3	-	0,68	0,76
KK4001P0200	1	200	259	136	84	40	-	3	-	0,82	0,89

3.1.9 KK40 adapter flanges



Adapter flange F0

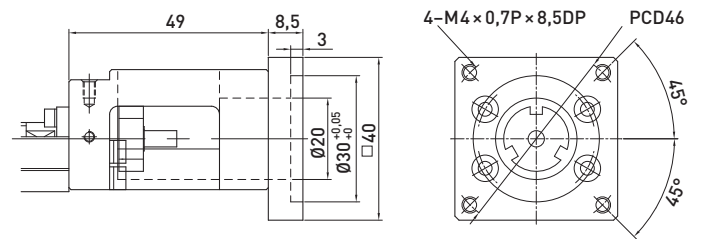

Adapter flange F1

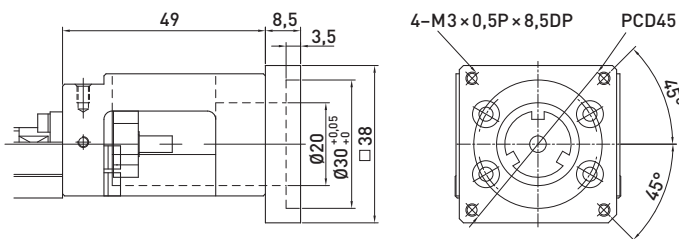

Adapter flange F2

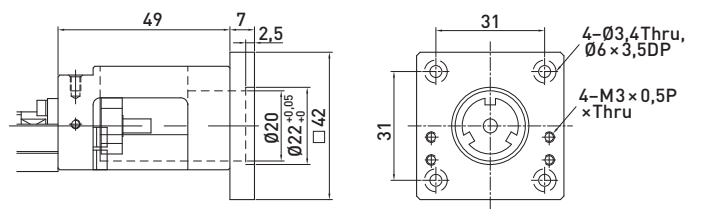

Adapter flange F3

Positioning Systems

Linear Axes KK

3.1.10 Linear axes KK50 without cover

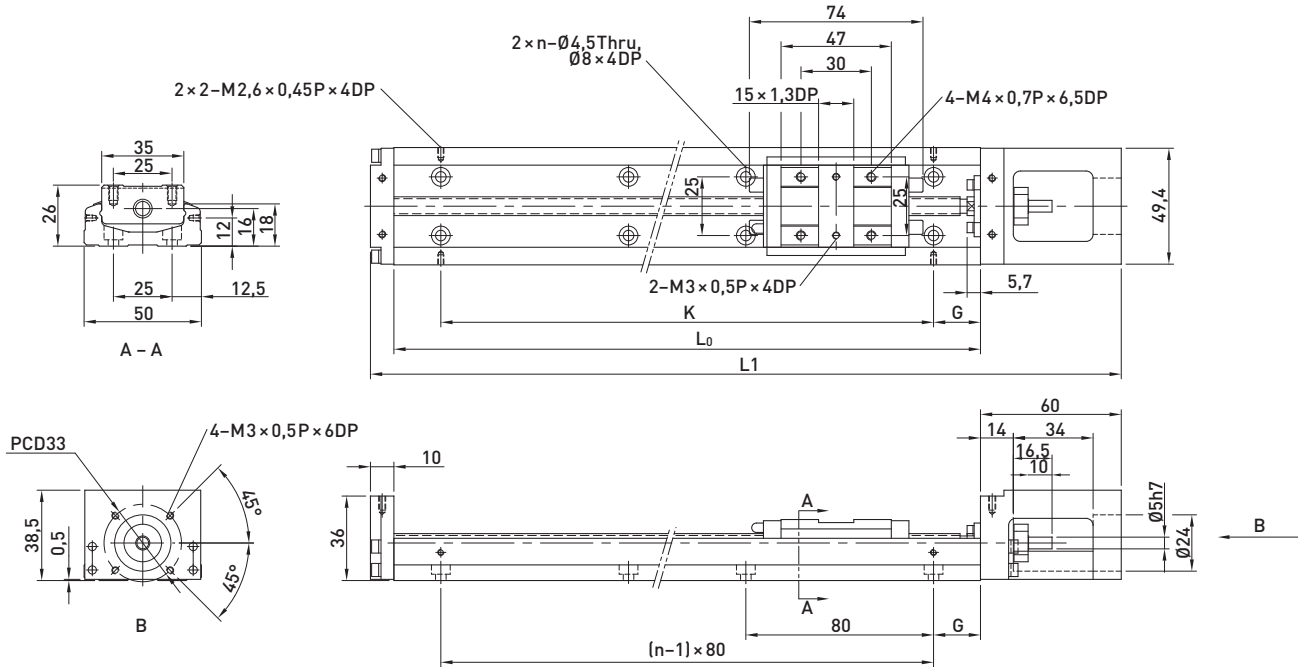

Table 3.50 Dimensions and mass of linear axes KK50 without cover

Model	Lead [mm]	L0 [mm]	L1 [mm]	Maximum stroke [mm]		G [mm]	K [mm]	n	m	Mass [kg]	
				Block A1	Block A2					Block A1	Block A2
KK5002P0150	2	150	220	70	-	35	80	2	-	1,00	-
KK5002P0200	2	200	270	120	55	20	160	3	-	1,20	1,40
KK5002P0250	2	250	320	170	105	45	160	3	-	1,40	1,60
KK5002P0300	2	300	370	220	155	30	240	4	-	1,60	1,80

3.1.11 Linear axes KK50 with aluminium cover

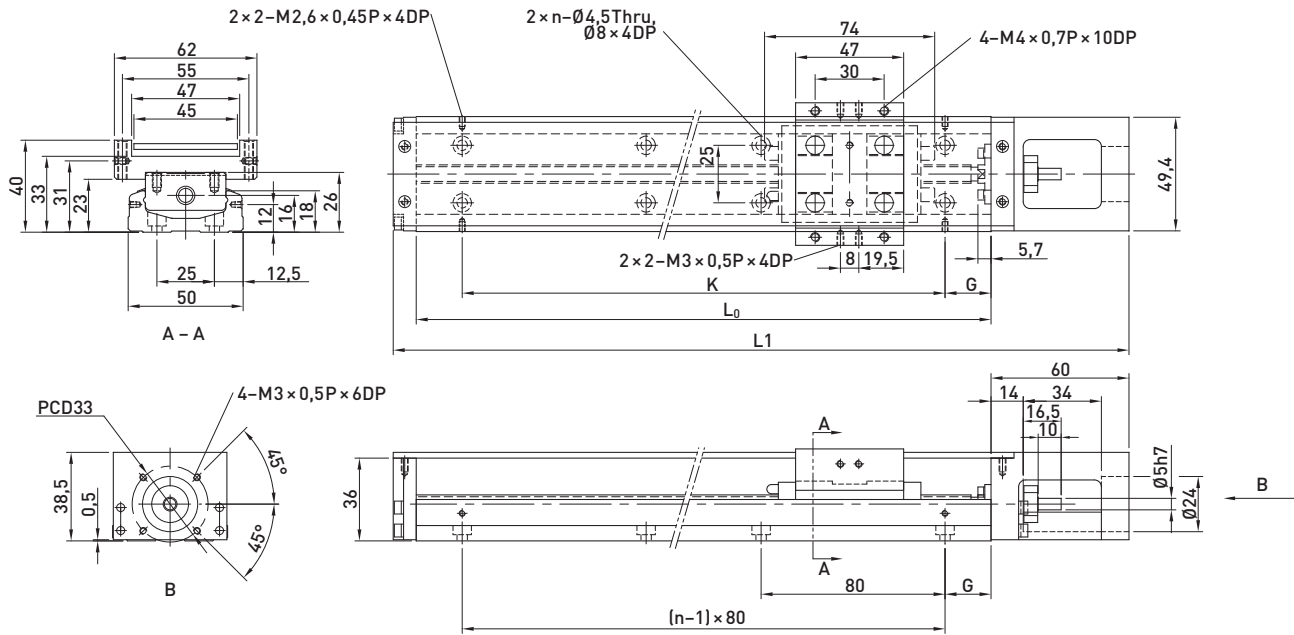

Table 3.51 Dimensions and mass of linear axes KK50 with aluminium cover

Model	Lead [mm]	L0 [mm]	L1 [mm]	Maximum stroke [mm]		G [mm]	K [mm]	n	m	Mass [kg]	
				Block A1	Block A2					Block A1	Block A2
KK5002P0150	2	150	220	70	-	35	80	2	-	1,10	-
KK5002P0200	2	200	270	120	55	20	160	3	-	1,30	1,50
KK5002P0250	2	250	320	170	105	45	160	3	-	1,60	1,80
KK5002P0300	2	300	370	220	155	30	240	4	-	1,80	2,00

Positioning Systems

Linear Axes KK

3.1.12 KK50 adapter flanges

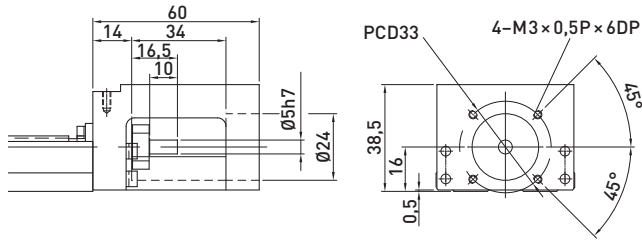

Adapter flange F0

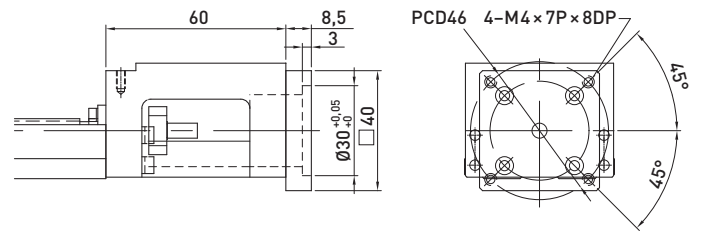

Adapter flange F1

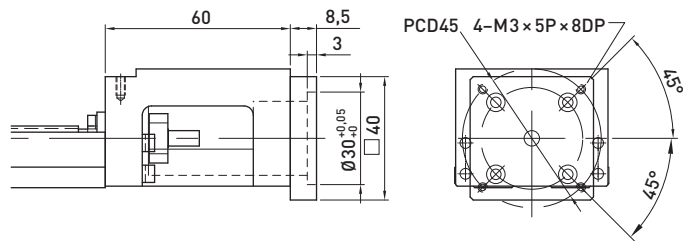

Adapter flange F2

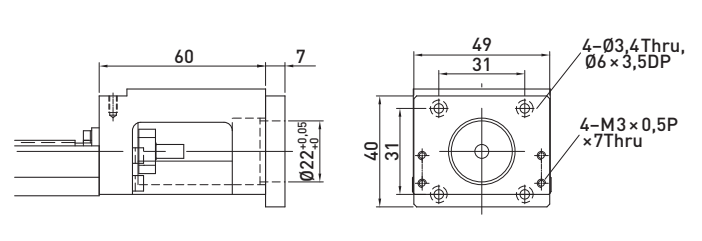

Adapter flange F3

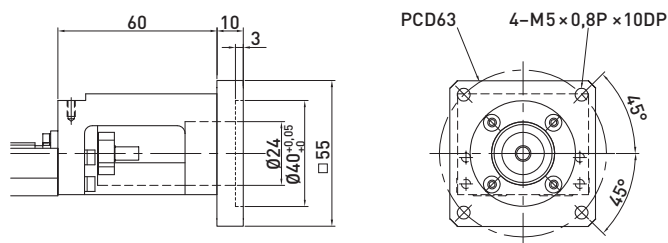

Adapter flange F4

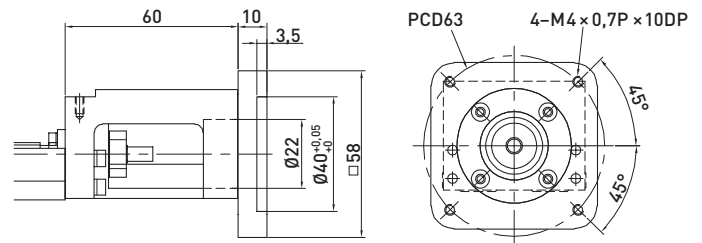

Adapter flange F5

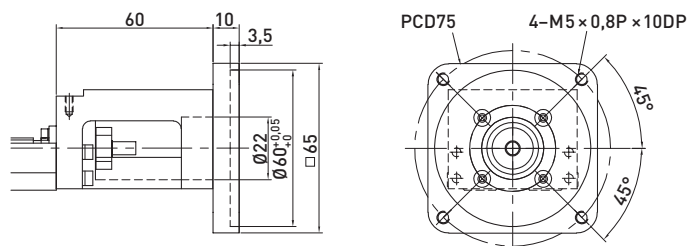

Adapter flange F6

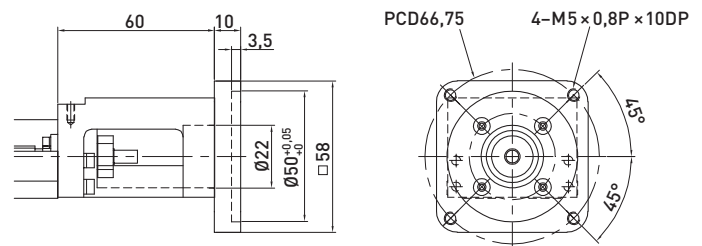

Adapter flange F7

3.1.13 Linear axes KK60 without cover, standard block

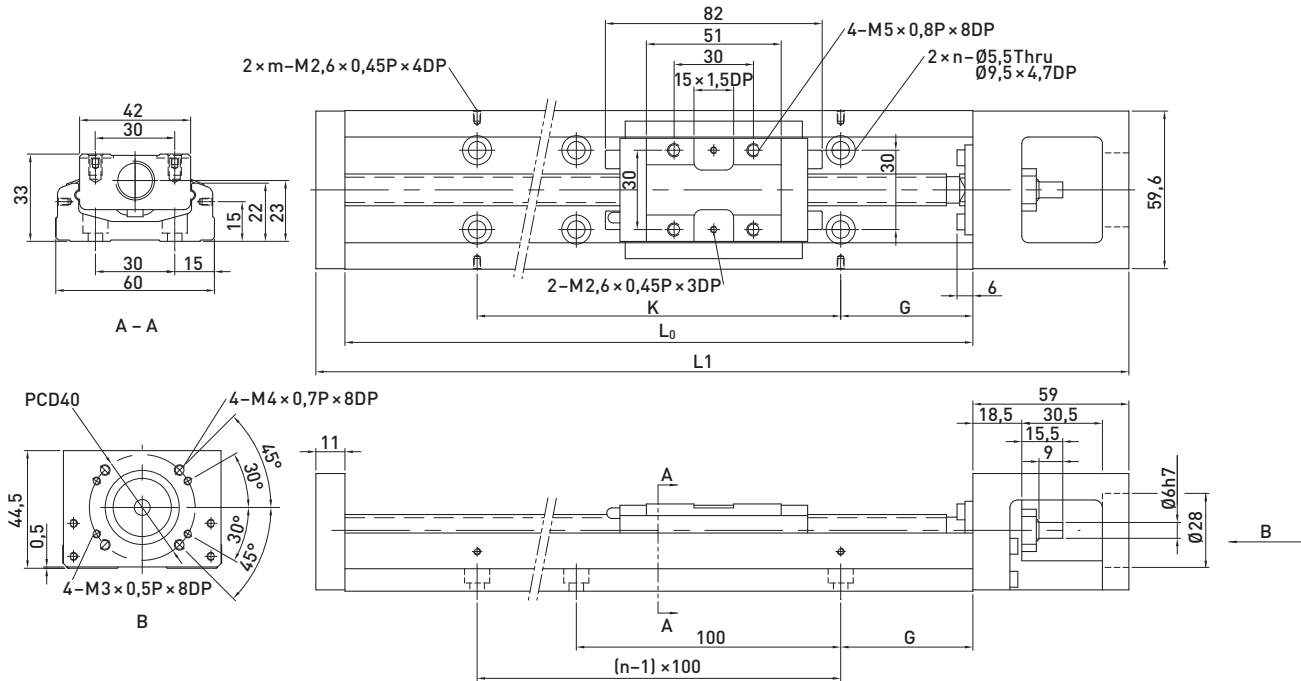

Table 3.52 Dimensions and mass of linear axes KK60 without cover, standard block

Model	Lead [mm]	L0 [mm]	L1 [mm]	Maximum stroke [mm]		G [mm]	K [mm]	n	m	Mass [kg]	
				Block A1	Block A2					Block A1	Block A2
KK6005P0150	5	150	220	60	-	25	100	2	2	1,50	-
KK6005P0200	5	200	270	110	-	50	100	2	2	1,80	-
KK6005P0300	5	300	370	210	135	50	200	3	2	2,40	2,70
KK6005P0400	5	400	470	310	235	50	100	4	4	3,00	3,30
KK6005P0500	5	500	570	410	335	50	200	5	3	3,60	3,90
KK6005P0600	5	600	670	510	435	50	100	6	6	4,20	4,60
KK6010P0150	10	150	220	60	-	25	100	2	2	1,50	-
KK6010P0200	10	200	270	110	-	50	100	2	2	1,80	-
KK6010P0300	10	300	370	210	135	50	200	3	2	2,40	2,70
KK6010P0400	10	400	470	310	235	50	100	4	4	3,00	3,30
KK6010P0500	10	500	570	410	335	50	200	5	3	3,60	3,90
KK6010P0600	10	600	670	510	435	50	100	6	6	4,20	4,60

Positioning Systems

Linear Axes KK

3.1.14 Linear axes KK60 without cover, short block

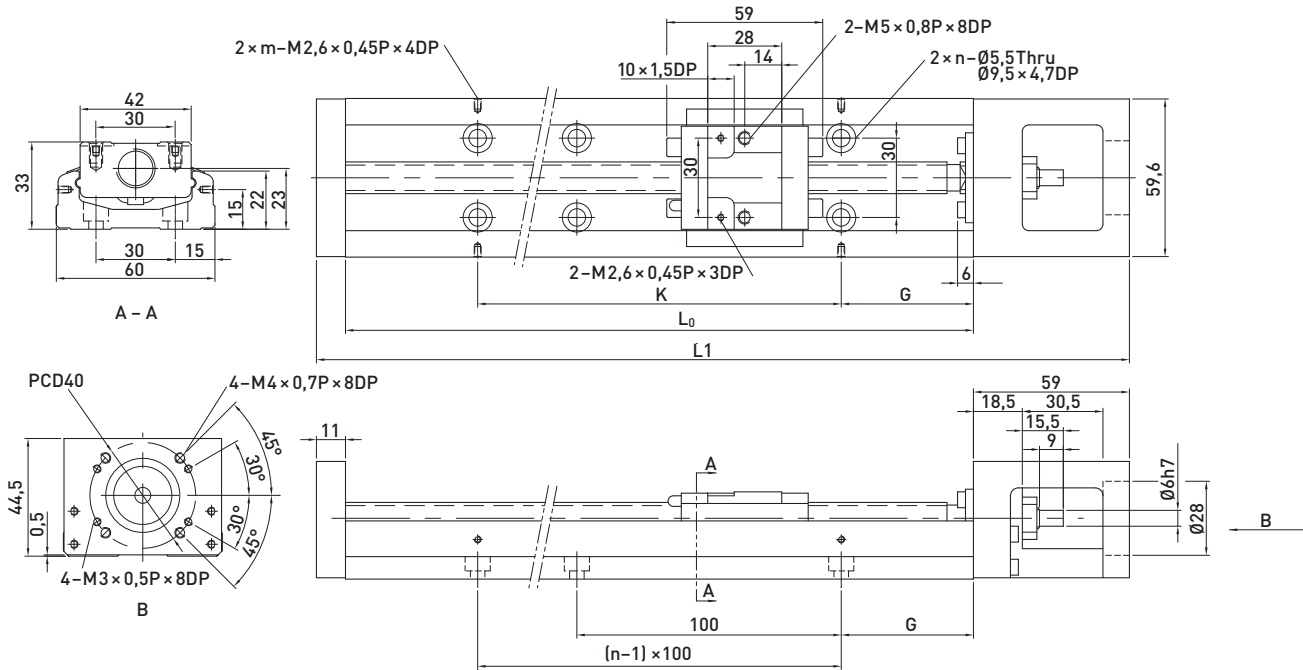

Table 3.53 Dimensions and mass of linear axes KK60 without cover, short block

Model	Lead [mm]	L0 [mm]	L1 [mm]	Maximum stroke [mm]		G [mm]	K [mm]	n	m	Mass [kg]	
				Block A1	Block A2					Block A1	Block A2
KK6005P0150	5	150	220	85	34	25	100	2	2	1,40	1,60
KK6005P0200	5	200	270	135	84	50	100	2	2	1,70	1,90
KK6005P0300	5	300	370	235	184	50	200	3	2	2,30	2,50
KK6005P0400	5	400	470	335	284	50	100	4	4	2,90	3,10
KK6005P0500	5	500	570	435	384	50	200	5	3	3,50	3,70
KK6005P0600	5	600	670	535	484	50	100	6	6	4,10	4,30
KK6010P0150	10	150	220	85	34	25	100	2	2	1,40	1,60
KK6010P0200	10	200	270	135	84	50	100	2	2	1,70	1,90
KK6010P0300	10	300	370	235	184	50	200	3	2	2,30	2,50
KK6010P0400	10	400	470	335	284	50	100	4	4	2,90	3,10
KK6010P0500	10	500	570	435	384	50	200	5	3	3,50	3,70
KK6010P0600	10	600	670	535	484	50	100	6	6	4,10	4,30

3.1.15 Linear axes KK60 with aluminium cover, standard block

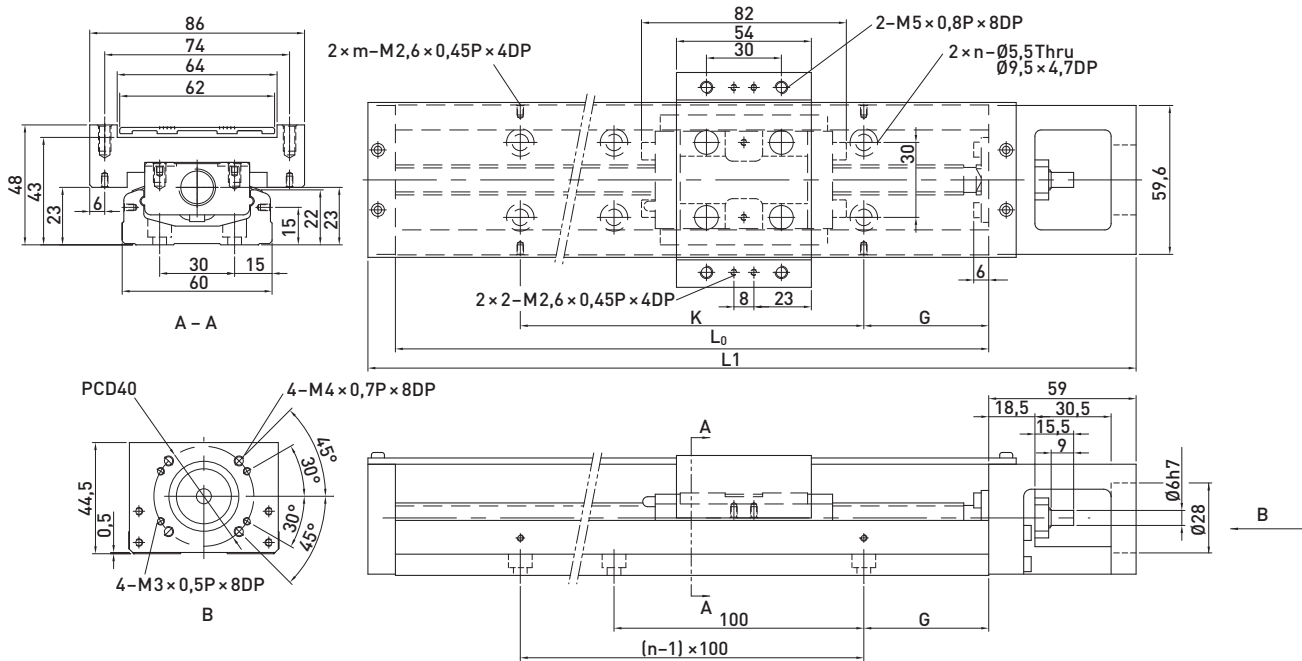

Table 3.54 Dimensions and mass of linear axes KK60 with cover, standard block

Model	Lead [mm]	L0 [mm]	L1 [mm]	Maximum stroke [mm]		G [mm]	K [mm]	n	m	Mass [kg]	
				Block A1	Block A2					Block A1	Block A2
KK6005P0150	5	150	220	60	-	25	100	2	2	1,70	-
KK6005P0200	5	200	270	110	-	50	100	2	2	2,10	-
KK6005P0300	5	300	370	210	135	50	200	3	2	2,70	3,00
KK6005P0400	5	400	470	310	235	50	100	4	4	3,30	3,60
KK6005P0500	5	500	570	410	335	50	200	5	3	3,90	4,20
KK6005P0600	5	600	670	510	435	50	100	6	6	4,40	5,00
KK6010P0150	10	150	220	60	-	25	100	2	2	1,70	-
KK6010P0200	10	200	270	110	-	50	100	2	2	2,10	-
KK6010P0300	10	300	370	210	135	50	200	3	2	2,70	3,00
KK6010P0400	10	400	470	310	235	50	100	4	4	3,30	3,60
KK6010P0500	10	500	570	410	335	50	200	5	3	3,90	4,20
KK6010P0600	10	600	670	510	435	50	100	6	6	4,40	5,00

Positioning Systems

Linear Axes KK

3.1.16 Linear axes KK60 with aluminium cover, short block

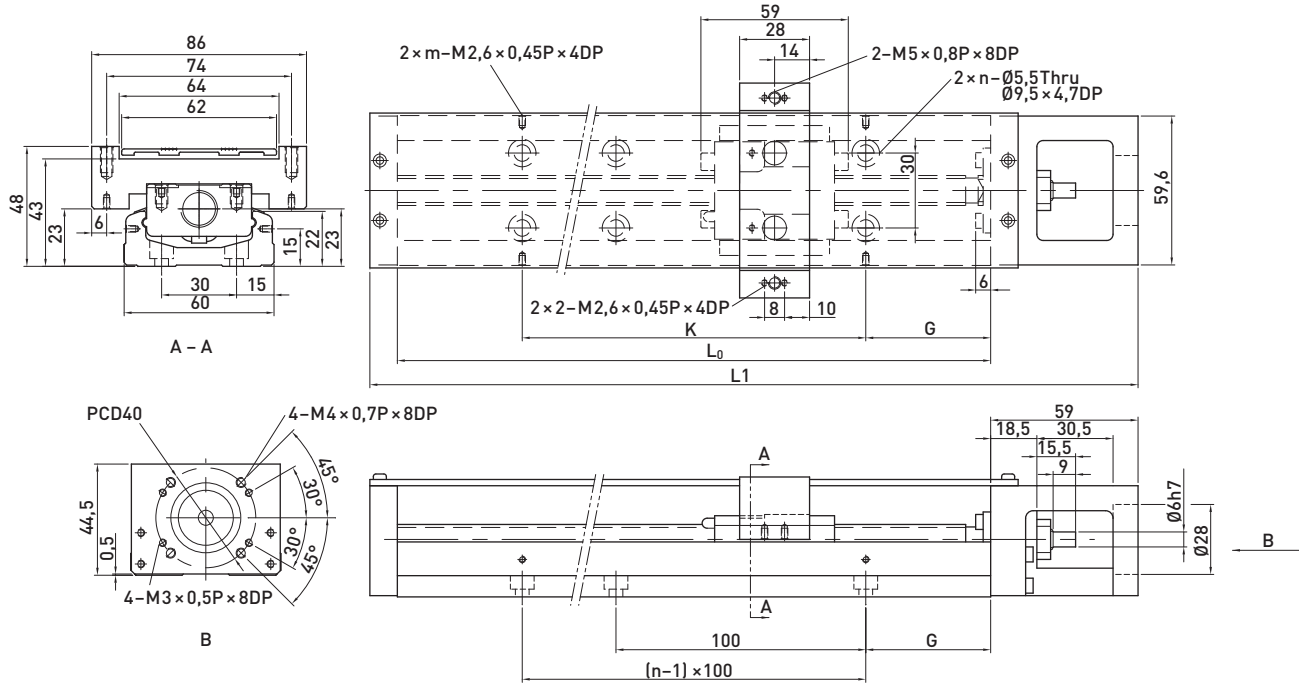

Table 3.55 Dimensions and mass of linear axes KK60 with cover, short block

Model	Lead [mm]	L0 [mm]	L1 [mm]	Maximum stroke [mm]		G [mm]	K [mm]	n	m	Mass [kg]	
				Block A1	Block A2					Block A2	Block A1
KK6005P0150	5	150	220	85	34	25	100	2	2	1,80	1,60
KK6005P0200	5	200	270	135	84	50	100	2	2	2,10	1,90
KK6005P0300	5	300	370	235	184	50	200	3	2	2,70	2,50
KK6005P0400	5	400	470	335	284	50	100	4	4	3,30	3,10
KK6005P0500	5	500	570	435	384	50	200	5	3	3,90	3,70
KK6005P0600	5	600	670	535	484	50	100	6	6	4,60	4,40
KK6010P0150	10	150	220	85	34	25	100	2	2	1,80	1,60
KK6010P0200	10	200	270	135	84	50	100	2	2	2,10	1,90
KK6010P0300	10	300	370	235	184	50	200	3	2	2,70	2,50
KK6010P0400	10	400	470	335	284	50	100	4	4	3,30	3,10
KK6010P0500	10	500	570	435	384	50	200	5	3	3,90	3,70
KK6010P0600	10	600	670	535	484	50	100	6	6	4,60	4,40

3.1.17 Linear axes KK60 with bellow cover

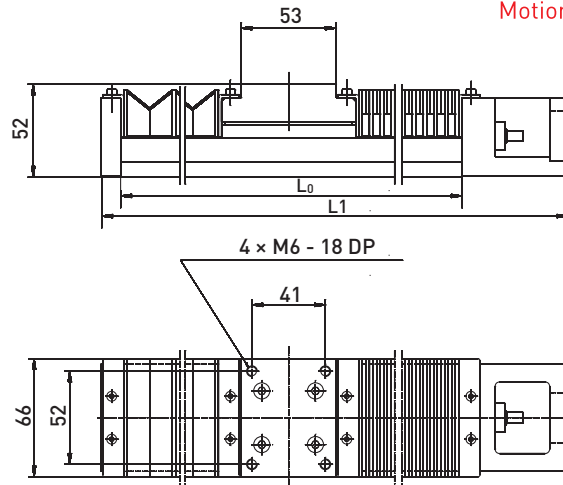

Table 3.56 Dimensions and mass of linear axes KK60 with bellow cover

Model	Lead [mm]	L0 [mm]	L1 [mm]	Maximum stroke [mm]	Mass [kg]
KK6005P0150	5	150	220	45	1,70
KK6005P0200	5	200	270	77	2,10
KK6005P0300	5	300	370	151	2,70
KK6005P0400	5	400	470	230	3,30
KK6005P0500	5	500	570	300	3,90
KK6005P0600	5	600	670	376	4,60
KK6010P0150	10	150	220	45	1,70
KK6010P0200	10	200	270	77	2,10
KK6010P0300	10	300	370	151	2,70
KK6010P0400	10	400	470	230	3,30
KK6010P0500	10	500	570	300	3,90
KK6010P0600	10	600	670	376	4,60

Positioning Systems

Linear Axes KK

3.1.18 KK60 adapter flanges

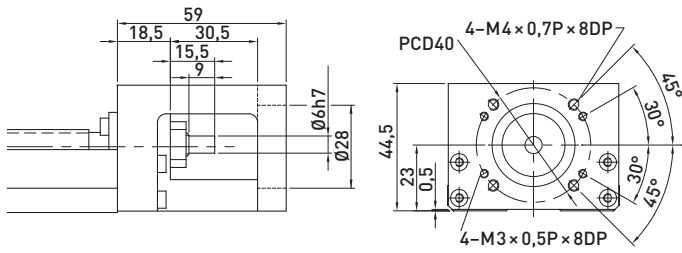

Adapter flange F0

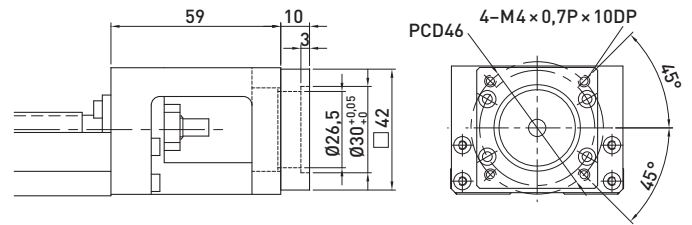

Adapter flange F1

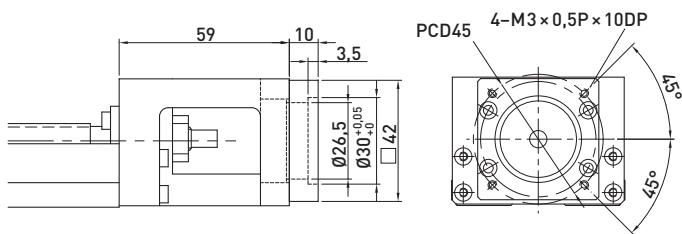

Adapter flange F2

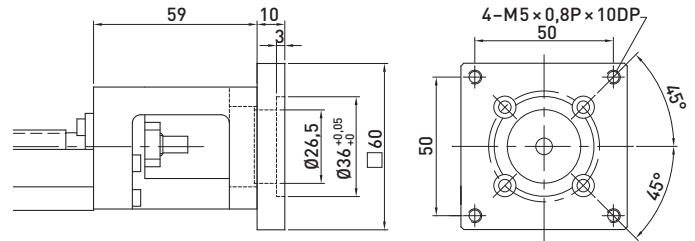

Adapter flange F3

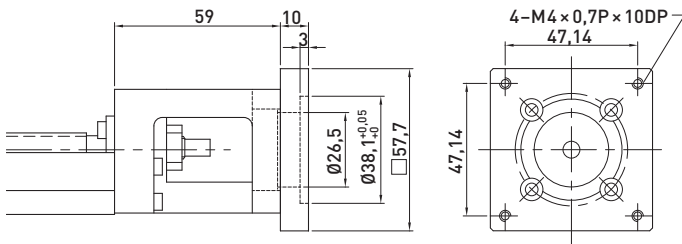

Adapter flange F4

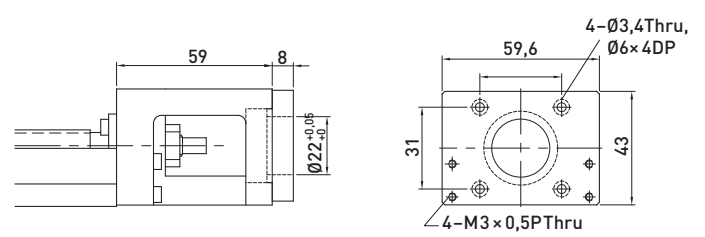

Adapter flange F5

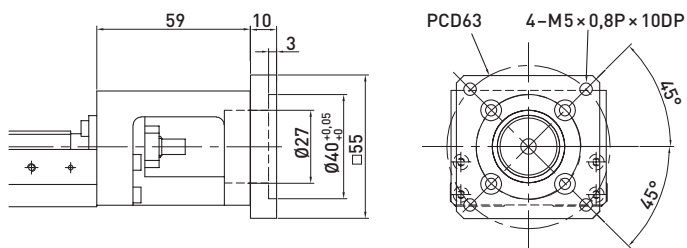

Adapter flange F6

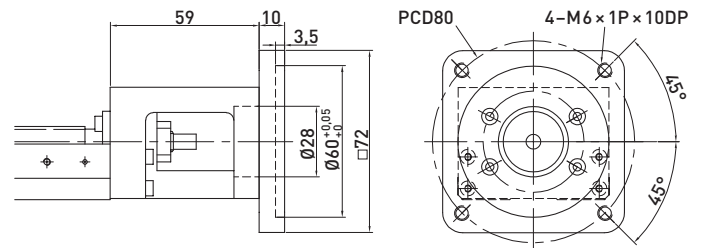

Adapter flange F7

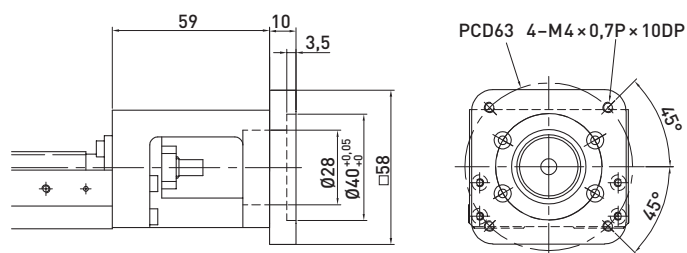

Adapter flange F8

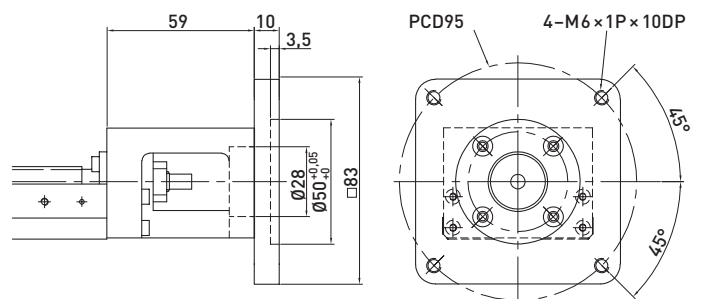

Adapter flange F9

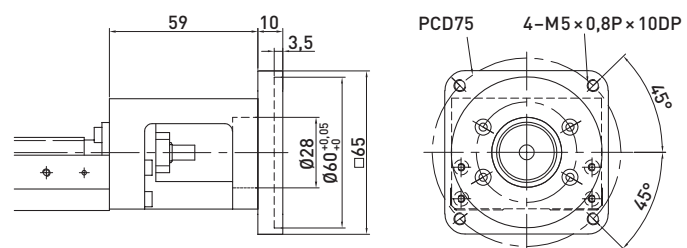

Adapter flange F10

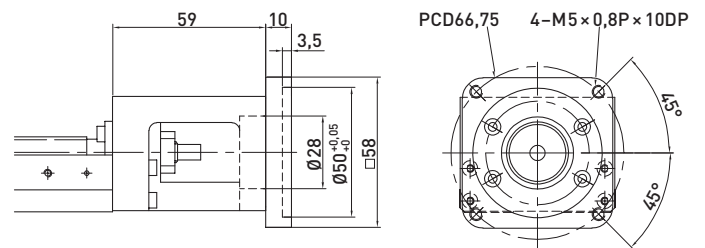

Adapter flange F11

Positioning Systems

Linear Axes KK

3.1.19 Linear axes KK86 without cover

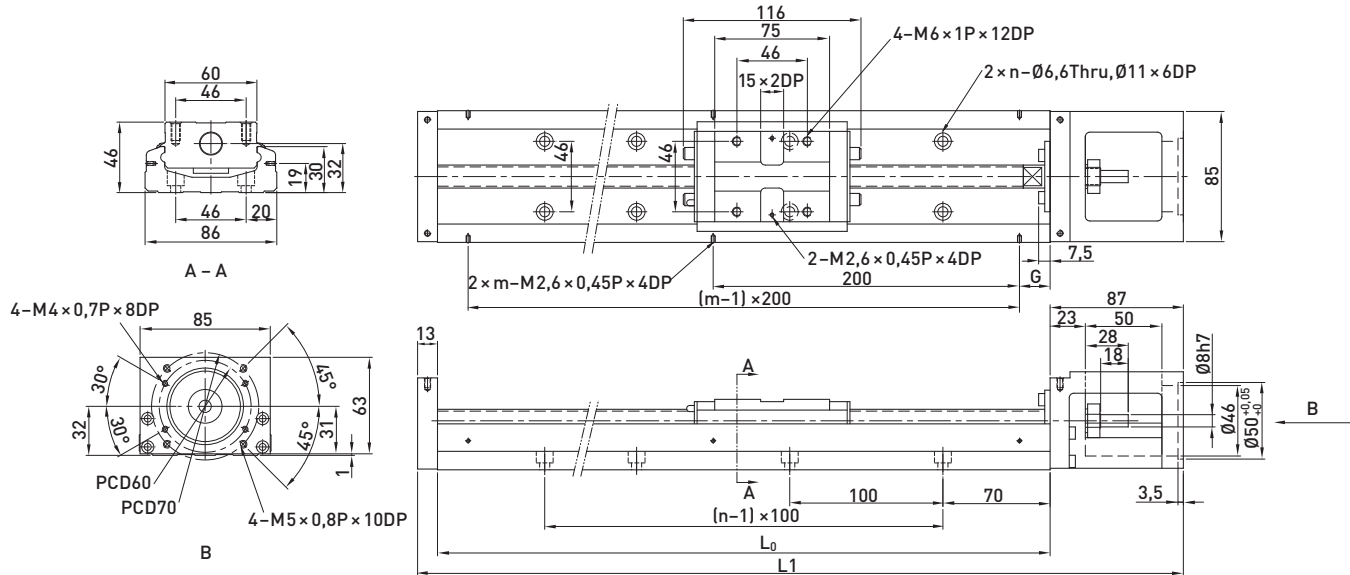

Table 3.57 Dimensions and mass of linear axes KK86 without cover

Model	Lead [mm]	L0 [mm]	L1 [mm]	Maximum stroke [mm]		G [mm]	K [mm]	n	m	Mass [kg]	
				Block A1	Block A2					Block A1	Block A2
KK8610P0340	10	340	440	210	100	70	-	3	2	5,70	6,50
KK8610P0440	10	440	540	310	200	20	-	4	3	6,90	7,70
KK8610P0540	10	540	640	410	300	70	-	5	3	8,00	8,80
KK8610P0640	10	640	740	510	400	20	-	6	4	9,20	10,00
KK8610P0740	10	740	840	610	500	70	-	7	4	10,40	11,20
KK8610P0940	10	940	1040	810	700	70	-	9	5	11,60	12,40
KK8620P0340	20	340	440	210	100	70	-	3	2	5,70	6,50
KK8620P0440	20	440	540	310	200	20	-	4	3	6,90	7,70
KK8620P0540	20	540	640	410	300	70	-	5	3	8,00	8,80
KK8620P0640	20	640	740	510	400	20	-	6	4	9,20	10,00
KK8620P0740	20	740	840	610	500	70	-	7	4	10,40	11,20
KK8620P0940	20	940	1040	810	700	70	-	9	5	11,60	12,40

3.1.20 Linear axes KK86 with aluminium cover

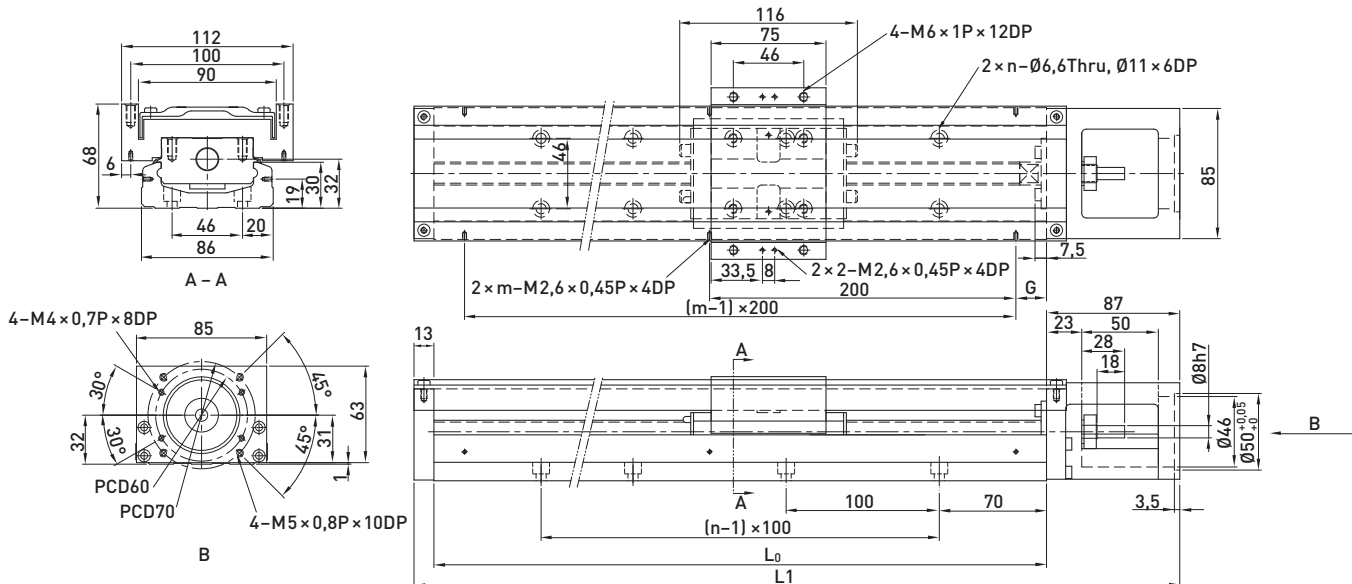

Table 3.58 Dimensions and mass of linear axes KK86 with aluminium cover

Model	Lead [mm]	L0 [mm]	L1 [mm]	Maximum stroke [mm]		G [mm]	K [mm]	n	m	Mass [kg]	
				Block A1	Block A2					Block A1	Block A2
KK8610P0340	10	340	440	210	100	70	-	3	2	6,50	7,30
KK8610P0440	10	440	540	310	200	20	-	4	3	7,80	8,60
KK8610P0540	10	540	640	410	300	70	-	5	3	9,00	9,80
KK8610P0640	10	640	740	510	400	20	-	6	4	10,30	11,30
KK8610P0740	10	740	840	610	500	70	-	7	4	11,60	12,40
KK8610P0940	10	940	1040	810	700	70	-	9	5	13,00	13,80
KK8620P0340	20	340	440	210	100	70	-	3	2	6,50	7,30
KK8620P0440	20	440	540	310	200	20	-	4	3	7,80	8,60
KK8620P0540	20	540	640	410	300	70	-	5	3	9,00	9,80
KK8620P0640	20	640	740	510	400	20	-	6	4	10,30	11,30
KK8620P0740	20	740	840	610	500	70	-	7	4	11,60	12,40
KK8620P0940	20	940	1040	810	700	70	-	9	5	13,00	13,80

Positioning Systems

Linear Axes KK

3.1.21 Linear axes KK86 with bellow cover

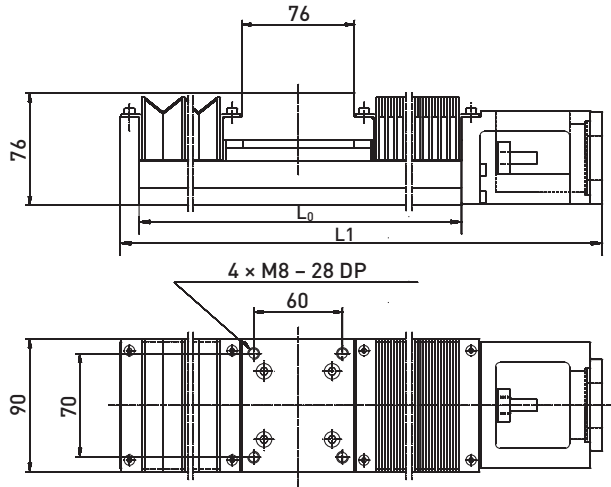
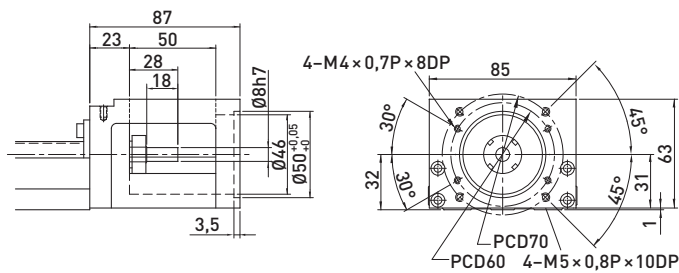

Table 3.59 Dimensions and mass of linear axes KK86 with bellow cover

Model	Lead [mm]	L0 [mm]	L1 [mm]	Maximum stroke [mm]	Mass [kg]
KK8610P0340	10	340	440	174	6,30
KK8610P0440	10	440	540	248	7,60
KK8610P0540	10	540	640	327	8,80
KK8610P0640	10	640	740	410	10,00
KK8610P0740	10	740	840	491	11,30
KK8610P0940	10	940	1040	654	12,70
KK8620P0340	20	340	440	174	6,30
KK8620P0440	20	440	540	248	7,60
KK8620P0540	20	540	640	327	8,80
KK8620P0640	20	640	740	410	10,00
KK8620P0740	20	740	840	491	11,30
KK8620P0940	20	940	1040	654	12,70

3.1.22 KK86 adapter flanges



Adapter flange F0

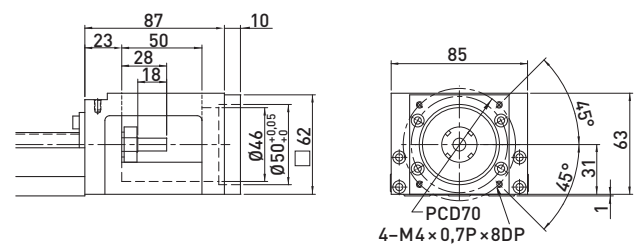

Adapter flange F1

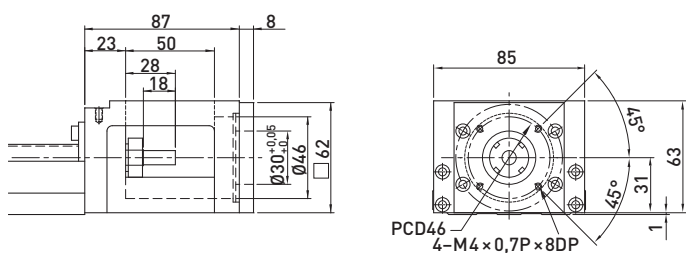

Adapter flange F2

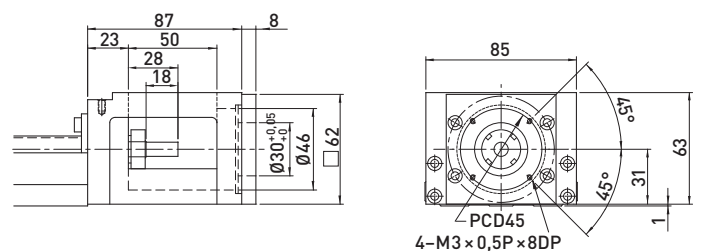

Adapter flange F3

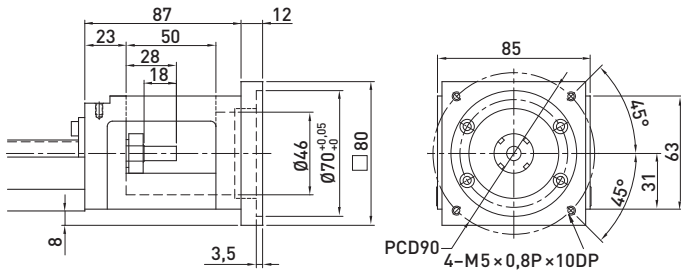

Adapter flange F4

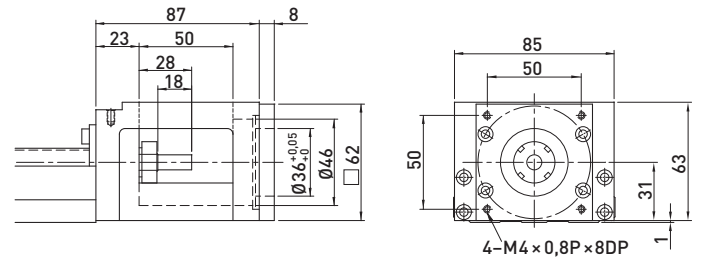

Adapter flange F5

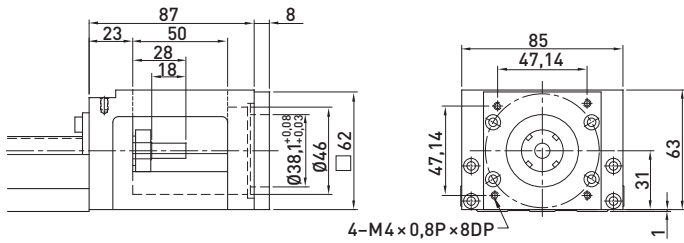

Adapter flange F6

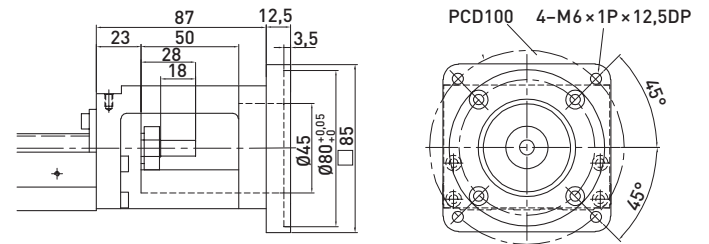

Adapter flange F7

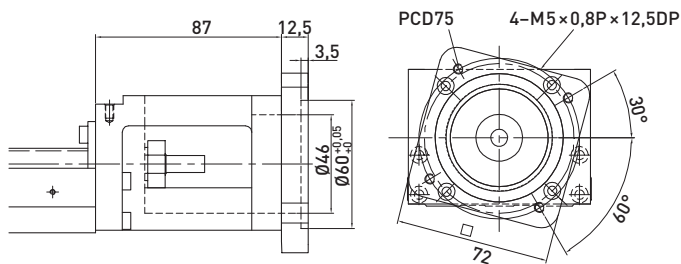

Adapter flange F8

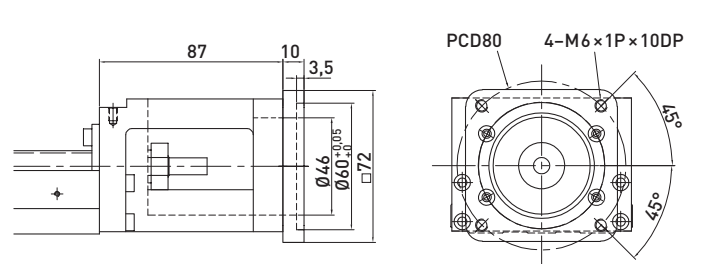

Adapter flange F9

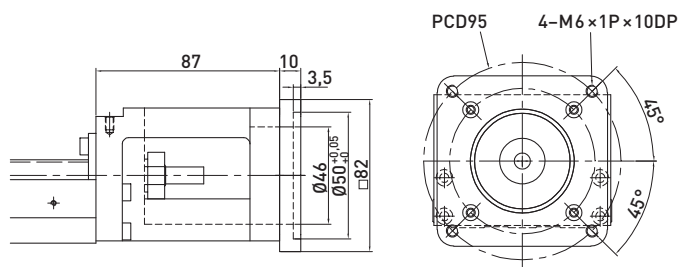

Adapter flange F10

Positioning Systems

Linear Axes KK

3.1.23 Linear axes KK100 without cover

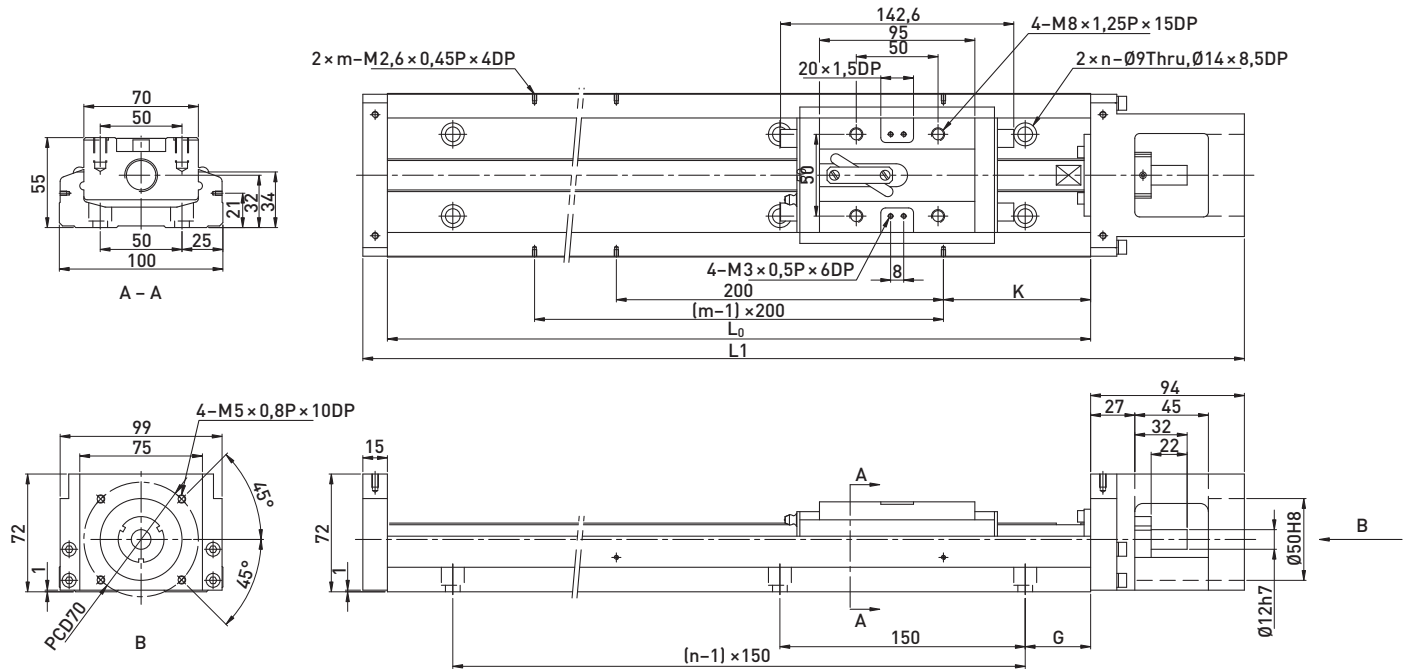

Table 3.60 Dimensions and mass of linear axes KK100 without cover

Model	Lead [mm]	L0 [mm]	L1 [mm]	Maximum stroke [mm]		G [mm]	K [mm]	n	m	Mass [kg]	
				Block A1	Block A2					Block A1	Block A2
KK10020P0980	20	980	1089	828	700	40	90	7	5	18,60	20,30
KK10020P1080	20	1080	1189	928	800	15	40	8	6	20,30	22,00
KK10020P1180	20	1180	1289	1028	900	65	90	8	6	22,00	23,70
KK10020P1280	20	1280	1389	1128	1000	40	40	9	7	23,60	25,30
KK10020P1380	20	1380	1489	1228	1100	15	90	10	7	25,30	27,00

3.1.24 Linear axes KK100 with aluminium cover

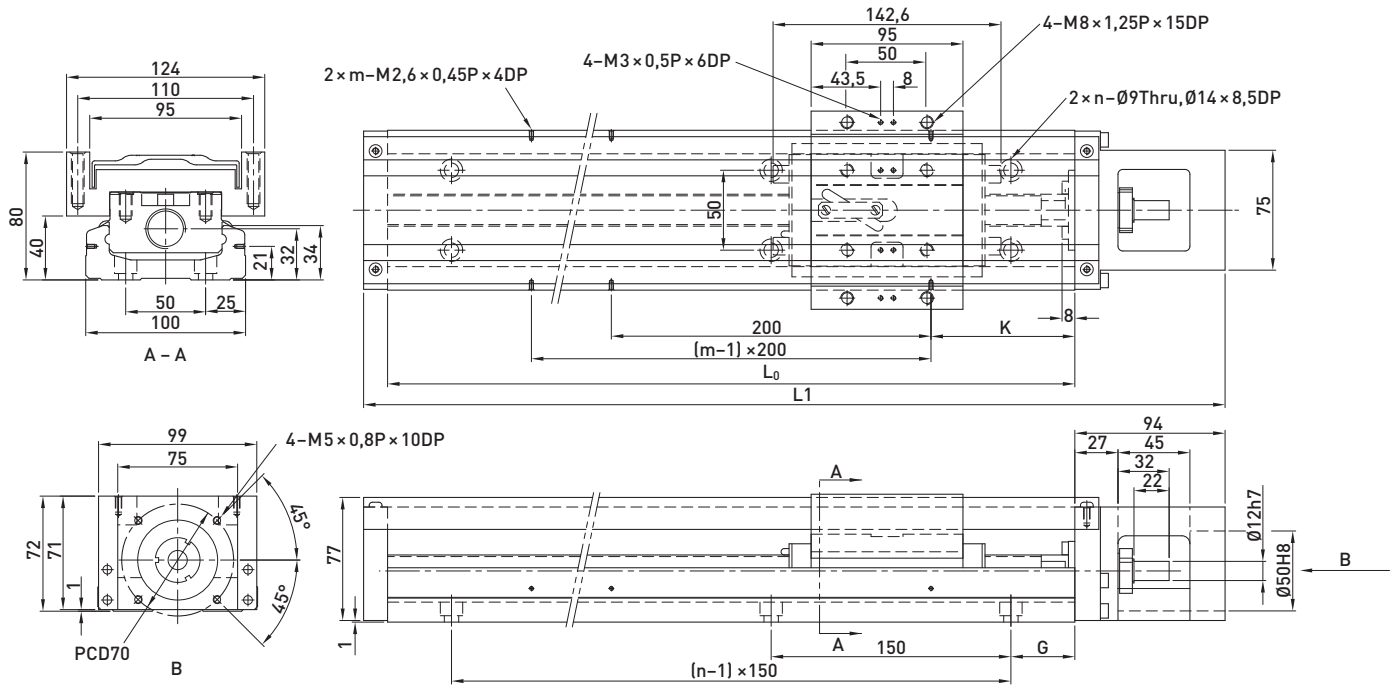

Table 3.61 Dimensions and mass of linear axes KK100 with aluminium cover

Model	Lead [mm]	L0 [mm]	L1 [mm]	Maximum stroke [mm]		G [mm]	K [mm]	n	m	Mass [kg]	
				Block A1	Block A2					Block A1	Block A2
KK10020P0980	20	980	1089	828	700	40	90	7	5	20,40	22,10
KK10020P1080	20	1080	1189	928	800	15	40	8	6	22,20	23,90
KK10020P1180	20	1180	1289	1028	900	65	90	8	6	24,00	25,70
KK10020P1280	20	1280	1389	1128	1000	40	40	9	7	25,70	27,40
KK10020P1380	20	1380	1489	1228	1100	15	90	10	7	27,50	29,20

Positioning Systems

Linear Axes KK

3.1.25 KK100 adapter flanges

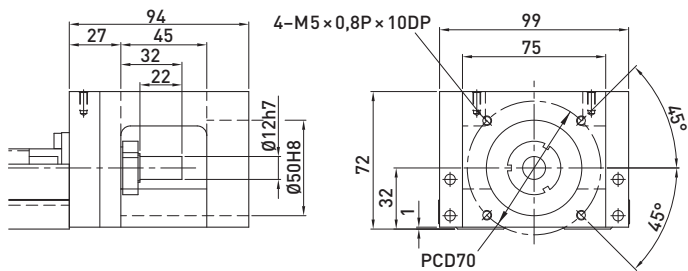

Adapter flange F0

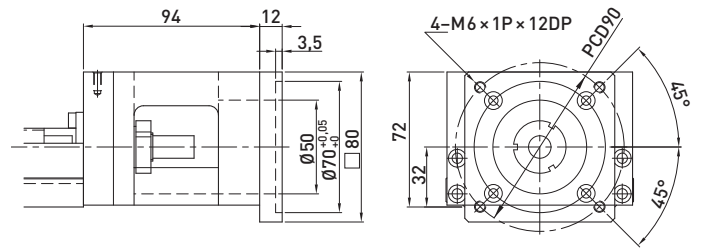

Adapter flange F1

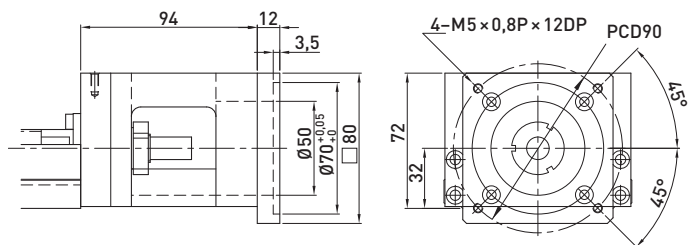

Adapter flange F2

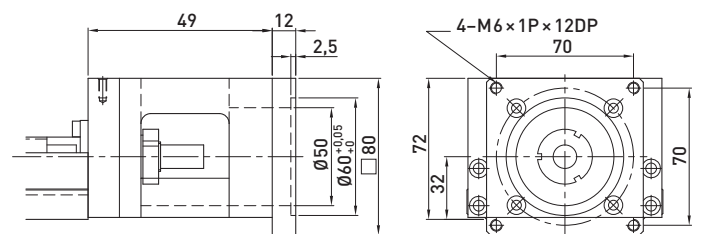

Adapter flange F3

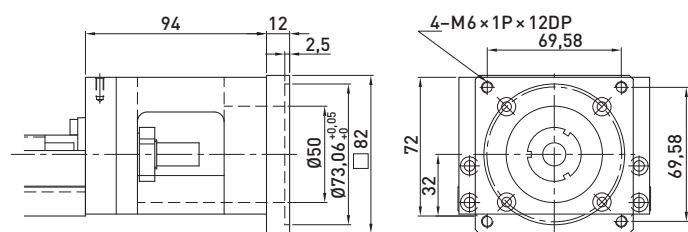

Adapter flange F4

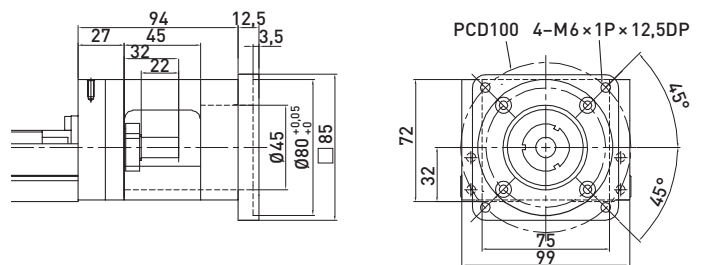

Adapter flange F5

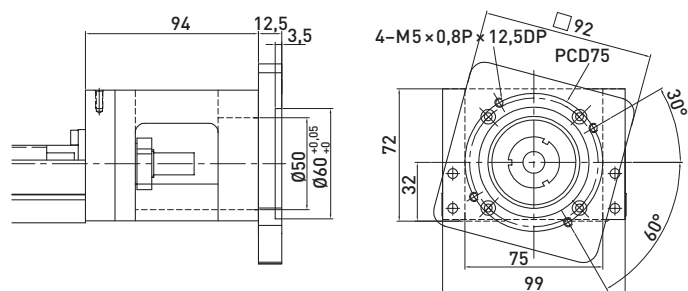

Adapter flange F6

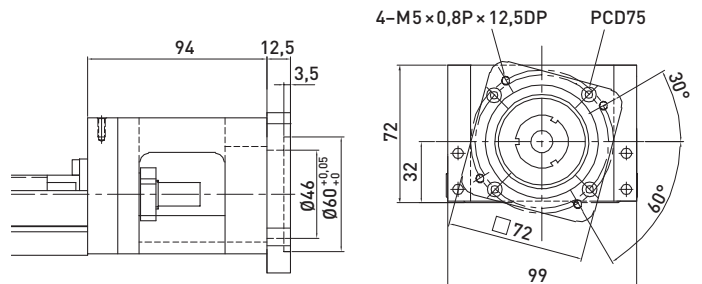

Adapter flange F7

3.1.26 Linear axes KK130 without cover

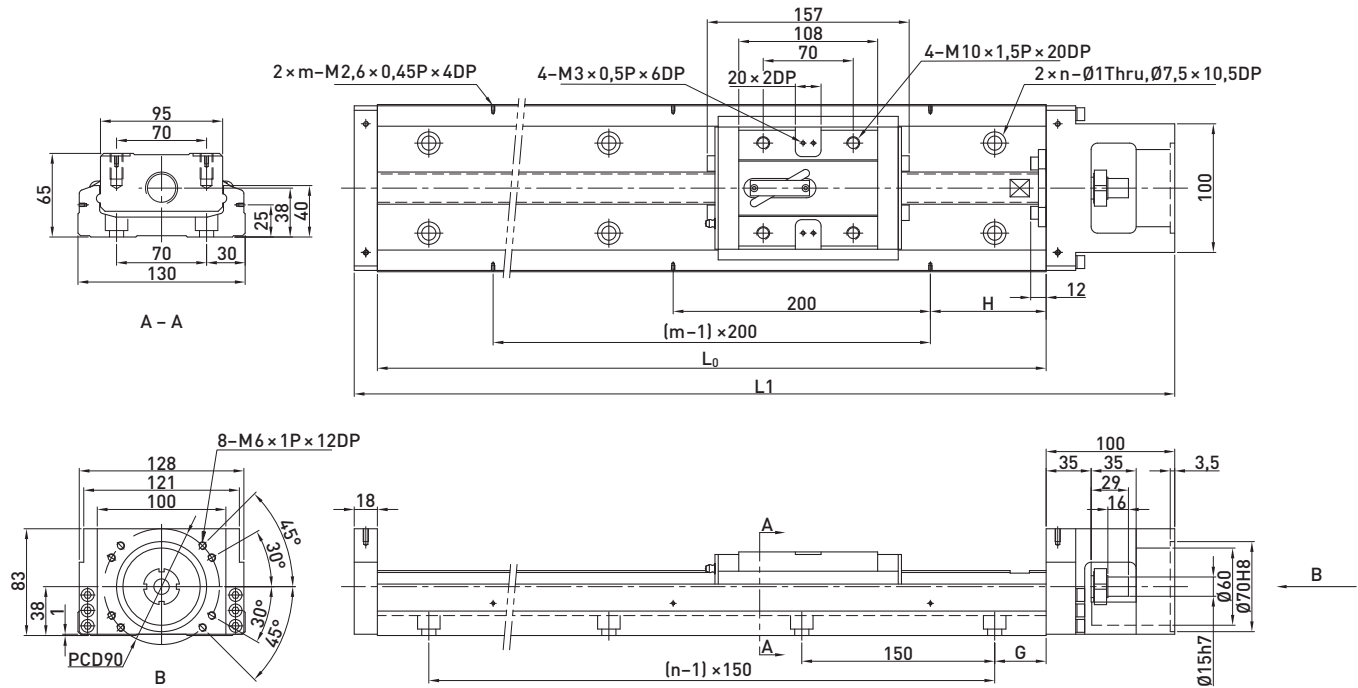

Table 3.62 Dimensions and mass of linear axes KK130 without cover

Model	Lead [mm]	L0 [mm]	L1 [mm]	Maximum stroke [mm]		G [mm]	K [mm]	n	m	Mass [kg]	
				Block A1	Block A2					Block A1	Block A2
KK13025P0980	25	980	1098	811	659	40	90	7	5	29,40	32,30
KK13025P1180	25	1180	1298	1011	859	65	90	8	6	34,30	37,20
KK13025P1380	25	1380	1498	1211	1059	90	90	9	7	39,20	42,10
KK13025P1680	25	1680	1798	1511	1359	90	40	11	9	46,50	49,40

Positioning Systems

Linear Axes KK

3.1.27 Linear axes KK130 with aluminium cover

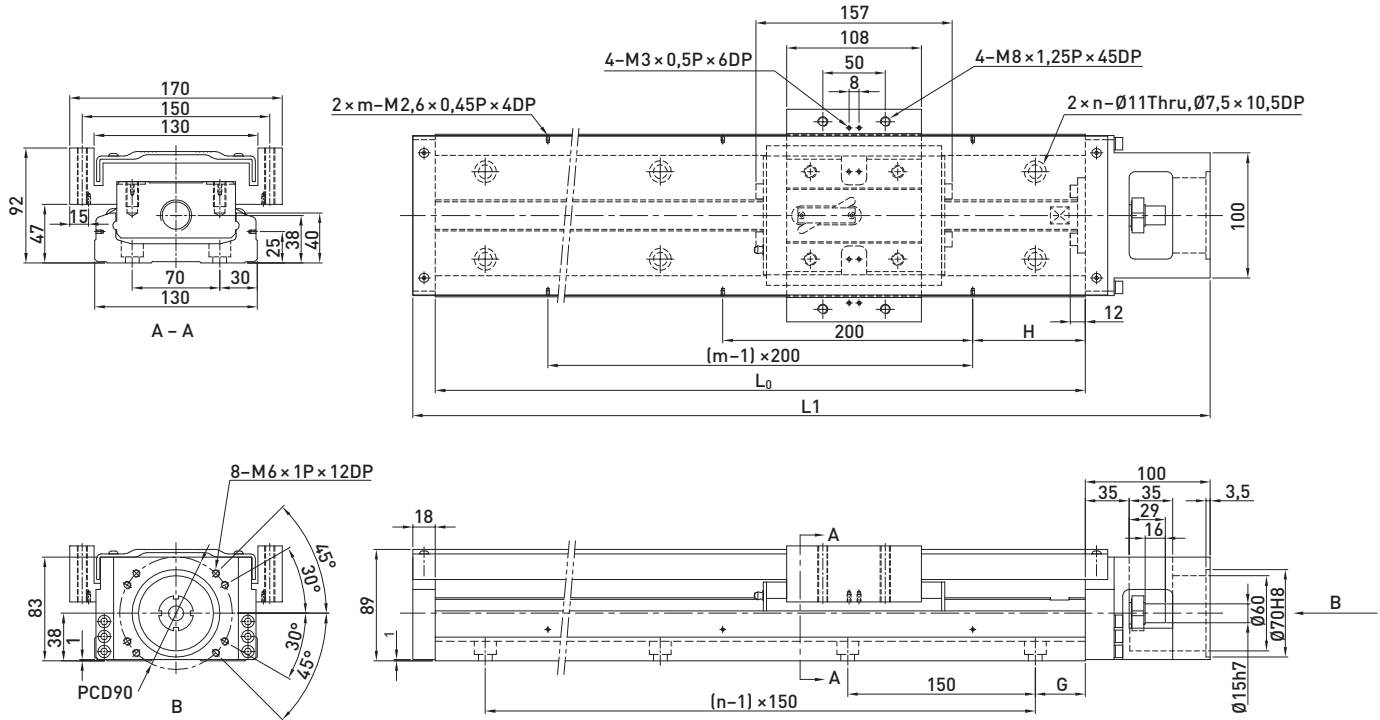
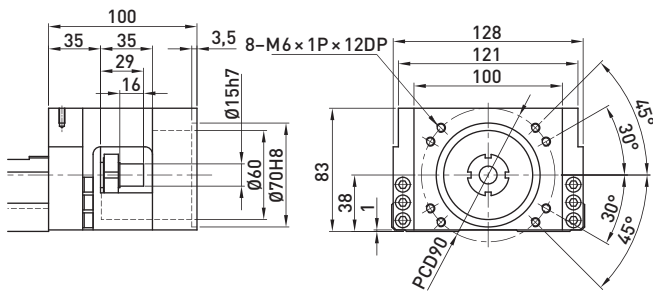

Table 3.63 Dimensions and mass of linear axes KK130 with aluminium cover

Model	Lead [mm]	L0 [mm]	L1 [mm]	Maximum stroke [mm]		G [mm]	K [mm]	n	m	Mass [kg]	
				Block A1	Block A2					Block A1	Block A2
KK13025P0980	25	980	1098	811	659	40	90	7	5	31,90	35,90
KK13025P1180	25	1180	1298	1011	859	65	90	8	6	37,10	41,10
KK13025P1380	25	1380	1498	1211	1059	90	90	9	7	42,20	46,20
KK13025P1680	25	1680	1798	1511	1359	90	40	11	9	49,90	53,90

3.1.28 KK130 adapter flanges



Adapter flange F0

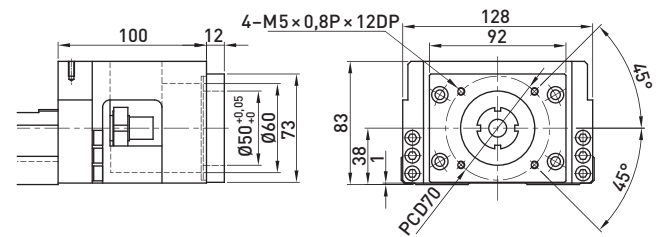

Adapter flange F1

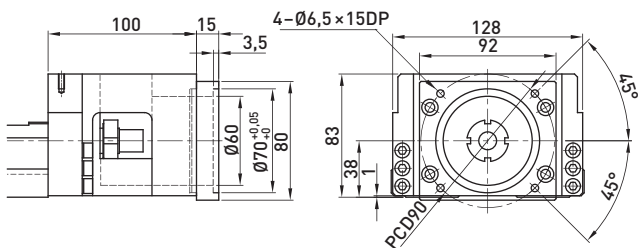

Adapter flange F2

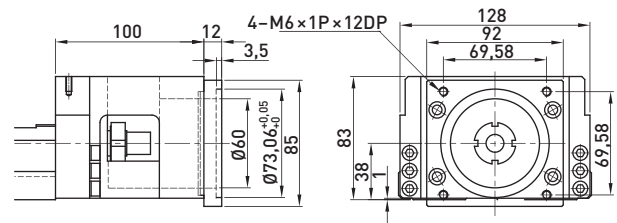

Adapter flange F3

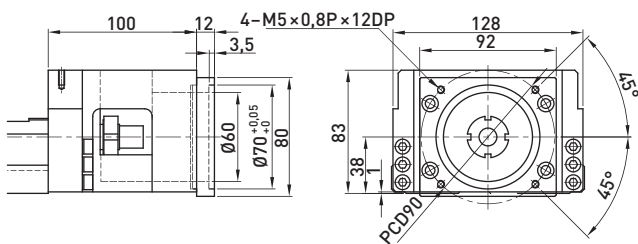

Adapter flange F4

Positioning Systems

Linear Axes KK

3.1.29 Accessory linear axes KK

Table 3.64 Article overview of adapter flanges for KK linear axes

Model	Adapter flange	Article number set (comprising adapter flange and fixing screws)
KK40	KK-40-F1	8-11-0205
	KK-40-F2	8-11-0206
	KK-40-F3	8-11-0207
KK50	KK-50-F1	8-11-0209
	KK-50-F2	8-11-0210
	KK-50-F3	8-11-0211
	KK-50-F4	8-11-0120
	KK-50-F5	8-11-0212
	KK-50-F6	8-11-0213
	KK-50-F7	8-11-0214
KK60	KK-60-F1	8-11-0215
	KK-60-F2	8-11-0216
	KK-60-F3	8-11-0217
	KK-60-F4	8-11-0218
	KK-60-F5	8-11-0219
	KK-60-F6	8-11-0129
	KK-60-F7	8-11-0220
	KK-60-F8	8-11-0221
	KK-60-F9	8-11-0222
	KK-60-F10	8-11-0223
	KK-60-F11	8-11-0224
KK86	KK-86-F1	8-11-0225
	KK-86-F2	8-11-0226
	KK-86-F3	8-11-0227
	KK-86-F4	8-11-0228
	KK-86-F5	8-11-0229
	KK-86-F6	8-11-0230
	KK-86-F7	8-11-0132
	KK-86-F8	8-11-0068
	KK-86-F9	8-11-0231
	KK-86-F10	8-11-0232
KK100	KK-100-F1	8-11-0233
	KK-100-F2	8-11-0234
	KK-100-F3	8-11-0235
	KK-100-F4	8-11-0236
	KK-100-F5	8-11-0132
	KK-100-F6	8-11-0237
	KK-100-F7	8-11-0068
KK130	KK-130-F1	10-11-0001
	KK-130-F2	10-11-0002
	KK-130-F3	10-11-0003
	KK-130-F4	10-11-0004

Table 3.65 Article overview of sensor rails for KK linear axes

KK sizes	Article number Sensor rail set (comprising sensor rail and fixing materials, cam switch)
KKx4001P100A1	8-11-0239
KKx4001P150A1	8-11-0240
KKx4001P200A1	8-11-0241
KKx5002P150A1	8-11-0242
KKx5002P200A1	8-11-0243
KKx5002P250A1	8-11-0244
KKx5002P300A1	8-11-0245
KKx60xxP150EA1	8-11-0246
KKx60xxP200EA1	8-11-0247
KKx60xxP300EA1	8-11-0248
KKx60xxP400EA1	8-11-0249
KKx60xxP500EA1	8-11-0250
KKx60xxP600EA1	8-11-0251
KKx86xxP340A1	8-11-0252
KKx86xxP440A1	8-11-0253
KKx86xxP540A1	8-11-0254
KKx86xxP640A1	8-11-0255
KKx86xxP740A1	8-11-0256
KKx86xxP940A1	8-11-0257
KKx10020P980A1	8-11-0258
KKx10020P1080A1	8-11-0259
KKx10020P1180A1	8-11-0260
KKx10020P1280A1	8-11-0261
KKx10020P1380A1	8-11-0262
KKx13025P980A1	10-11-0010
KKx13025P980A1	10-11-0011
KKx13025P1380A1	10-11-0012
KKx13025P1680A1	10-11-0013

Switch set 8-11-0264

Consisting of fixing bracket, one inductive proximity switch and fixing materials. For use as a limit switch or reference switch.

Cable length: 4m

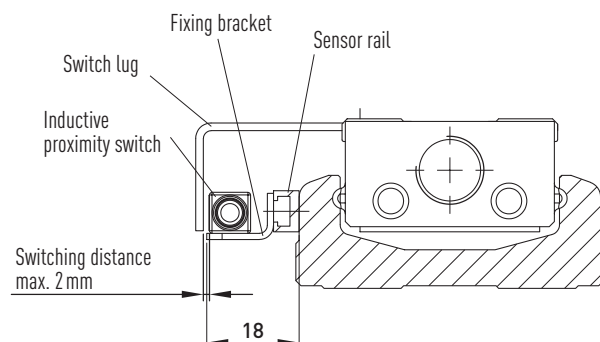

Positioning Systems

Linear Axes KK



Linear Guideways



Ballscrews

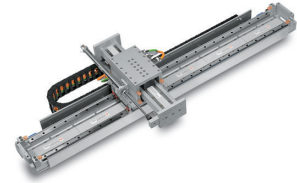

Linear Motor Systems



Linear Axes
with Ballscrews

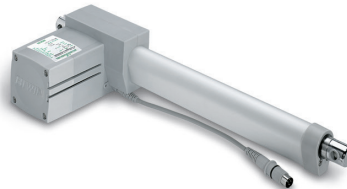

Linear Actuators



Ball Bearings



Linear Motor
Components



Rotary Tables



Drives

HIWIN GmbH
Brücklesbünd 2
D-77654 Offenburg
Telefon +49 (0) 7 81 9 32 78 - 0
Telefax +49 (0) 7 81 9 32 78 - 90
info@hiwin.de
www.hiwin.de

Vertriebsbüro Osnabrück
Franz-Lenz-Str. 4
49084 Osnabrück
Telefon +49 (0) 5 41 33 06 68 - 0
Telefax +49 (0) 5 41 33 06 68 - 29
osnabrueck@hiwin.de
www.hiwin.de

Vertriebsbüro Stuttgart
Max-Lang-Straße 56
70771 Leinfelden-Echterdingen
Telefon +49 (0) 7 11 79 47 09 - 0
Telefax +49 (0) 7 11 79 47 09 - 29
stuttgart@hiwin.de
www.hiwin.de

Verkoopkantoor Nederland
Fellinilaan 53
1325 SG Almere
Telefon +49 (0) 7 81 9 32 78 - 0
Telefax +49 (0) 7 81 9 32 78 - 90
info@hiwin.nl
www.hiwin.nl

Biuro dystrybucji Warszawa
ul. Putawska 405
PL-02-801 Warszawa
Telefon +48 (0) 22 544 07 07
Telefax +48 (0) 22 544 07 08
info@hiwin.pl
www.hiwin.pl

Értékesítési Iroda Budapest
Kis Gömb u. 19. Ú/1
H-1135 Budapest
Telefon +36 (06) 1 786 6461
Telefax +36 (06) 1 789 4786
info@hiwin.hu
www.hiwin.hu

HIWIN Srl
Via De Gasperi, 85
20017 Rho (MI)
Telefon +39 (0) 2 93 90 09 41
Telefax +39 (0) 2 93 46 93 24
info@hiwin.it
www.hiwin.it

HIWIN s.r.o.
Medkova 888/11
CZ-62700 BRNO
Telefon +42 05 48 528 238
Telefax +42 05 48 220 223
info@hiwin.cz
www.hiwin.cz

HIWIN s.r.o., o.z.z.o.
Mládežnícka 2101
SK-01701 Považská Bystrica
Telefon +421 424 43 47 77
Telefax +421 424 26 23 06
info@hiwin.sk
www.hiwin.sk

HIWIN (Schweiz) GmbH
Schachenstrasse 80
CH-8645 Jona
Telefon +41 (0) 55 225 00 25
Telefax +41 (0) 55 225 00 20
info@hiwin.ch
www.hiwin.ch

HIWIN France
24 ZI N 1 Est-BP 78
F-61302 L'Aigle Cedex
Telefon +33 (2) 33 34 11 15
Telefax +33 (2) 33 34 73 79
info@hiwin.fr
www.hiwin.fr

HIWIN Technologies Corp.
No. 7, Jingke Road
Taichung Precision Machinery Park
Taichung 40852, Taiwan
Telefon +886-4-2359-4510
Telefax +886-4-2359-4420
business@hiwin.com.tw
www.hiwin.com.tw

HIWIN Mikrosystem Corp.
No.7, Jingke Rd.
Nantun District
Taichung City 408, Taiwan
Telefon +886-4-2355-0110
Telefax +886-4-2355-0123
business@mail.hiwinmikro.com.tw
www.hiwinmikro.com.tw

HIWIN Corporation
3F. Sannomiya-Chuo Bldg.
4-2-20 Goko-Dori. Chuo-Ku
Kobe 651-0087, Japan
Telefon +81-78-262-5413
Telefax +81-78-262-5686
mail@hiwin.co.jp
www.hiwin.co.jp

HIWIN Corporation
Headquarters
1400 Madeline Ln.
Elgin, IL 60124, USA
Telefon +1-847-827 2270
Telefax +1-847-827 2291
info@hiwin.com
www.hiwin.com