

# FNS – Flanged, normal, standard height R1851 ... 2.



**Dynamic characteristics**

Travel speed:  $v_{max} = 4 \text{ m/s}$

Acceleration:  $a_{max} = 150 \text{ m/s}^2$

**Recommended combination based on preload and accuracy class**



- ▶ For preload C2: H and P (preferably)
- ▶ For preload C3: P and SP

**Material numbers**

Size	Roller Runner Block with size	Preload class		Accuracy class				Seals		
		C2	C3	H	P	SP	UP	DS	SS <sup>1)</sup>	AS
25	R1851 2	2		3	2	1	9	2X	–	–
			3		2	1	9	2X	–	–
35	R1851 3	2		3	2	1	9	2X	24	2A
			3		2	1	9	2X	24	2A
45	R1851 4	2		3	2	1	9	2X	24	2A
			3		2	1	9	2X	24	2A
55	R1851 5	2		3	2	1	9	2X	–	2A
			3		2	1	9	2X	–	2A
65	R1851 6	2		3	2	1	9	2X	–	–
			3		2	1	9	2X	–	–

1) In Preparation

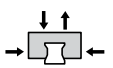
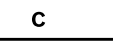
**Technical data**

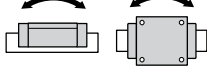
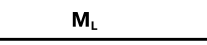
Size	Mass (kg)	Load ratings <sup>2)</sup> (N)		Torsional moment load capacity <sup>2)</sup> (Nm)		Longitudinal moment load capacity <sup>2)</sup> (Nm)	
							
	m	C	C <sub>0</sub>	M <sub>t</sub>	M <sub>t0</sub>	M <sub>L</sub>	M <sub>L0</sub>
25	0.73	26900	59500	348	770	260	580
35	2.15	61000	119400	1210	2370	760	1480
45	4.05	106600	209400	2640	5180	1650	3,240
55	5.44	140400	284700	4120	8350	2610	5290
65	10.72	237200	456300	8430	16210	5260	10120

2) Determination of the dynamic load capacities and load moments is based on a stroke travel of 100,000 m according to DIN ISO 14728-1. However, often only 50,000 m is actually stipulated. For comparison: Multiply values C, M<sub>t</sub> and M<sub>L</sub> from the table by 1.23.

**Order example**

Options:

- ▶ Roller Runner Block FNS
- ▶ Size 35
- ▶ Preload class C2
- ▶ Accuracy class H
- ▶ With double-lip seal 2X

Material number: R1851 323 2X

**Preload classes**

- C2 = Average preload
- C3 = High preload
- C1, C4, C5 upon request

**Seals**

- DS = Double-lip seal
- SS = Standard seal
- AS = Longitudinal seal

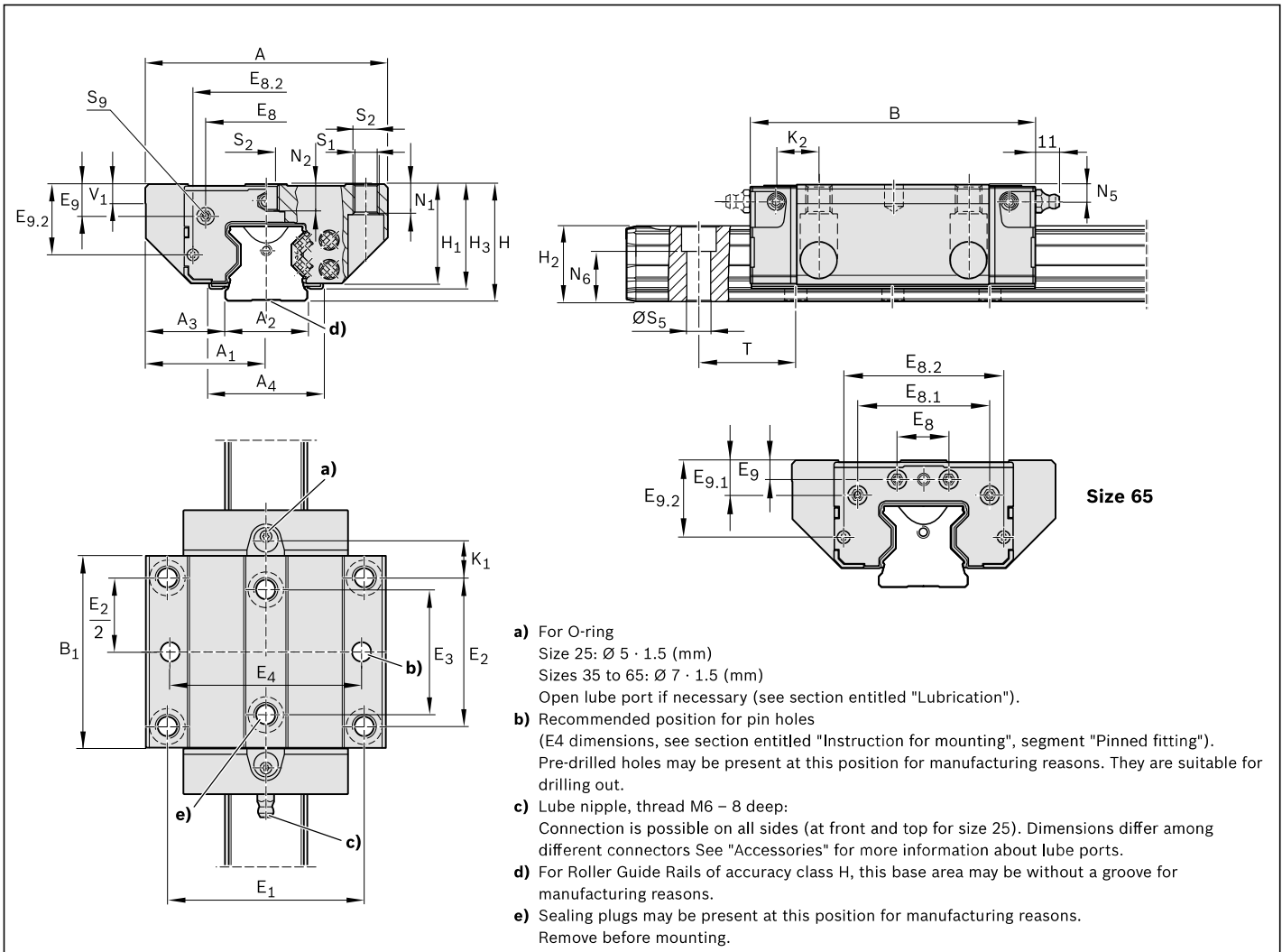

**Dimensions (mm)**

Size	A	A <sub>1</sub>	A <sub>2</sub>	A <sub>3</sub>	A <sub>4</sub> <sup>1)</sup>	B	B <sub>1</sub>	E <sub>1</sub>	E <sub>2</sub>	E <sub>3</sub>	E <sub>4</sub>	E <sub>8</sub>	E <sub>8.1</sub>	E <sub>8.2</sub>	E <sub>9</sub>	E <sub>9.1</sub>	E <sub>9.2</sub>
25	70	35	23	23.5	-	97.00	63.5	57	45	40	55	33.4	-	40.2	8.30	-	21.40
35	100	50	34	33.0	47.0	118.00	79.6	82	62	52	80	50.3	-	60.5	13.10	-	29.10
45	120	60	45	37.5	55.6	147.00	101.5	100	80	60	98	62.9	-	72.0	16.70	-	36.50
55	140	70	53	43.5	63.3	170.65	123.1	116	95	70	114	74.2	-	81.6	18.85	-	40.75
65	170	85	63	53.5	-	207.30	146.0	142	110	82	140	35.0	93	106.0	9.30	26	55.00

Size	H	H <sub>1</sub>	H <sub>2</sub> <sup>2)</sup>	H <sub>2</sub> <sup>3)</sup>	H <sub>3</sub> <sup>4)</sup>	K <sub>1</sub>	K <sub>2</sub>	N <sub>1</sub>	N <sub>2</sub>	N <sub>5</sub>	N <sub>6</sub> <sup>±0.5</sup>	Ø S <sub>1</sub>	S <sub>2</sub>	S <sub>5</sub>	S <sub>9</sub> <sup>5)</sup>	T <sup>6)</sup>	V <sub>1</sub>
25	36	30	23.60	23.40	-	14.05	-	9	7.3	5.5	14.3	6.7	M8	7	M3-6,5 deep	30.0	7.5
35	48	41	31.10	30.80	43	15.55	17.40	12	11.0	7.0	19.4	8.5	M10	9	M3-6,0 deep	40.0	8.0
45	60	51	39.10	38.80	53	17.45	20.35	15	13.5	8.0	22.4	10.4	M12	14	M4-9,0 deep	52.5	10.0
55	70	58	47.85	47.55	60	21.75	24.90	18	13.7	9.0	28.7	12.4	M14	16	M5-8,0 deep	60.0	12.0
65	90	76	58.15	57.85	-	30.00	33.00	23	21.5	9.3	36.5	14.6	M16	18	M4-8,0 deep	75.0	15.0

- 1) Dimension A<sub>4</sub> = Width of the additional longitudinal seal
- 2) Dimension H<sub>2</sub> with cover strip
- 3) Dimension H<sub>2</sub> without cover strip
- 4) Dimension H<sub>3</sub> = Total Roller Runner Block including the additional longitudinal seal
- 5) Thread for connecting parts
- 6) T = Rail separation of the Roller Guide Rail