

SSR

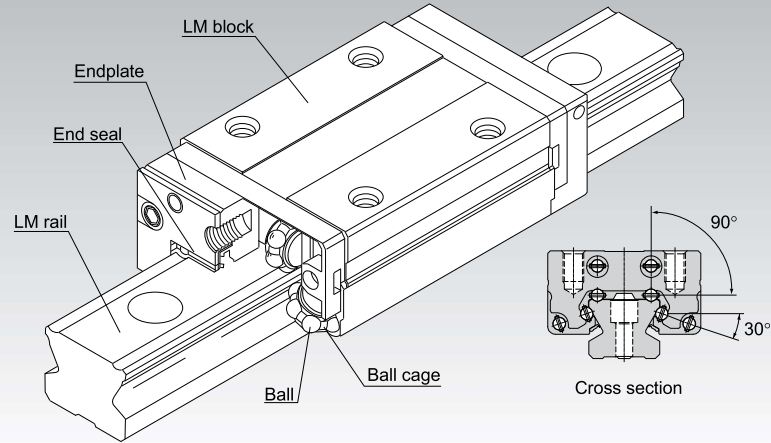

Caged Ball LM Guide Radial Type Model SSR



*For the Ball Cage, see [A1-88](#).

Point of Selection	A1-10
Point of Design	A1-436
Options	A1-459
Model No.	A1-523
Precautions on Use	A1-529
Accessories for Lubrication	A24-1
Mounting Procedure and Maintenance	B1-89
Equivalent moment factor	A1-43
Rated Loads in All Directions	A1-58
Equivalent factor in each direction	A1-60
Radial Clearance	A1-70
Accuracy Standards	A1-76
Shoulder Height of the Mounting Base and the Corner Radius	A1-449
Permissible Error of the Mounting Surface	A1-452
Dimensions of Each Model with an Option Attached	A1-472

Structure and Features

Balls roll in four rows of raceways precision-ground on an LM rail and an LM block, and ball cages and endplates incorporated in the LM block allow the balls to circulate.

Use of the ball cage eliminates friction between balls and increases grease retention, thus to achieve low noise, high speed and long-term maintenance-free operation.

[Compact, Radial Type]

Since it is a compactly designed model that has a low sectional height and a ball contact structure in the radial direction, this model is optimal for horizontal guide units.

[Superb Planar Running Accuracy]

Use of a ball contact structure that is highly resistant to loads in the radial direction minimizes radial displacement under radial loads and provides stable, highly accurate motion.

[Self-adjustment Capability]

The self-adjustment capability through front-to-front configuration of THK's unique circular-arc grooves (DF set) enables a mounting error to be absorbed even under a preload, thus to achieve highly accurate, smooth straight motion.

[Stainless Steel Type also Available as Standard]

A stainless steel type with its LM block, LM rail and balls all made of stainless steel, which is superbly corrosion resistant, is also available as standard.

Types and Features

Model SSR-XW

With this type, the LM block has a smaller width (W) and tapped holes.

Specification Table⇒ **A1-108**

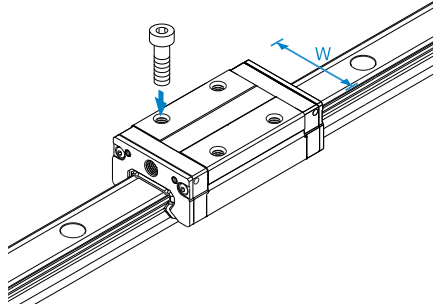

Model SSR-XV

This type has the same cross-sectional shape as SSR-XW but has a shorter overall LM block length (L).

Specification Table⇒ **A1-110**

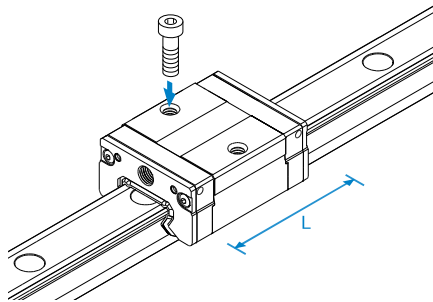

Model SSR-XTB

Since the LM block can be mounted from the bottom, this type is optimal for applications where through holes for mounting bolts cannot be drilled on the table.

Specification Table⇒ **A1-112**

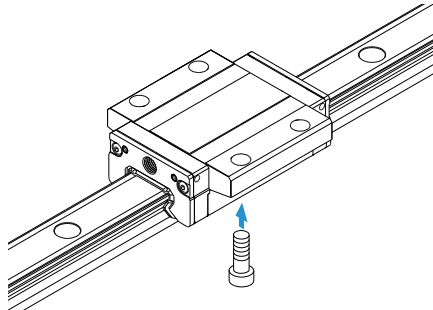

Models SSR-XW and SSR-XWM

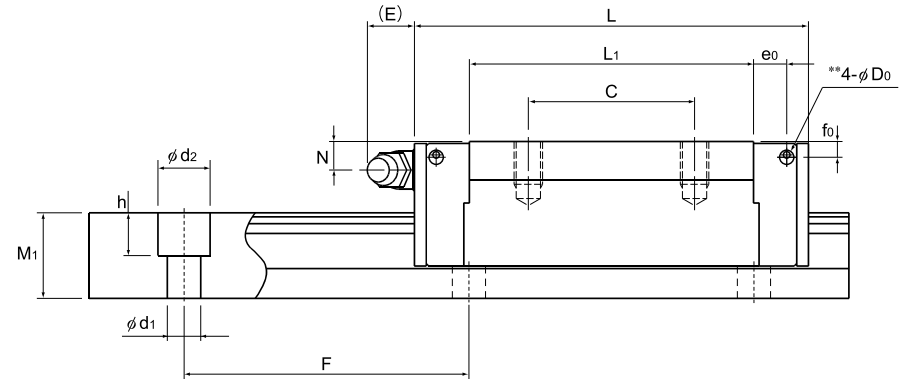
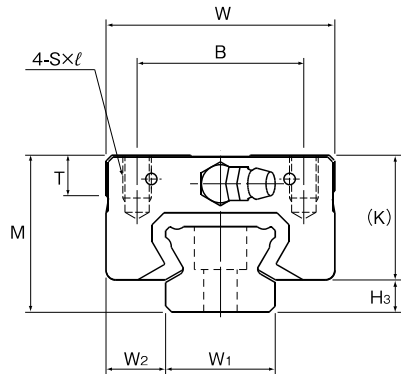

Unit: mm

Model No.	Outer dimensions			LM block dimensions												Grease nipple	H ₃	LM rail dimensions					Basic load rating		Static permissible moment kN-m*					Mass	
	Height	Width	Length	B	C	S × ℓ	L ₁	T	K	N	E	f ₀	e ₀	D ₀	Width			Height	Pitch	Length*	C	C ₀	M _A		M _B		M _C	LM block	LM rail		
	M	W	L	W ₁	W ₂	M ₁	F	d ₁ × d ₂ × h	Max	kN	kN	1 block	Double blocks	1 block	Double blocks			1 block	kg	kg/m											
SSR 15XW SSR 15XWM	24	34	56.9	26	26	M4 × 7	39.9	6.5	19.5	4.5	5.5	2.7	4.5	3	PB1021B	4.5	15	9.5	12.5	60	4.5 × 7.5 × 5.3	3000 (1240)	14.7	16.5	0.0792	0.44	0.0486	0.274	0.0962	0.15	1.2
SSR 20XW SSR 20XWM	28	42	66.5	32	32	M5 × 8	46.6	8.2	22	5.5	12	2.9	5.2	3	B-M6F	6	20	11	15.5	60	6 × 9.5 × 8.5	3000 (1480)	19.6	23.4	0.138	0.723	0.0847	0.448	0.18	0.25	2.1
SSR 25XW SSR 25XWM	33	48	83	35	35	M6 × 9	59.8	8.4	26.2	6	12	3.3	6.8	3	B-M6F	6.8	23	12.5	18	60	7 × 11 × 9	3000 (2020)	31.5	36.4	0.258	1.42	0.158	0.884	0.33	0.4	2.7
SSR 30XW SSR 30XWM	42	60	97	40	40	M8 × 12	70.7	11.3	32.5	8	12	4.5	7.6	4	B-M6F	9.5	28	16	23	80	7 × 11 × 9	3000 (2520)	46.5	52.7	0.446	2.4	0.274	1.49	0.571	0.8	4.3
SSR 35XW	48	70	110.9	50	50	M8 × 12	80.5	13	36.5	8.5	12	4.7	8.8	4	B-M6F	11.5	34	18	27.5	80	9 × 14 × 12	3000	64.6	71.6	0.711	3.72	0.437	2.31	0.936	1.1	6.4

Note) The M in the model number symbol indicates that the LM block, LM rail and balls are made of stainless steel. The stainless steel provides excellent corrosion and environmental resistance.

Note1) The maximum length under "Length*" indicates the standard maximum length of an LM rail. (See **A1-114**.)
 Static permissible moment* 1 block: the static permissible moment with one LM block
 Double blocks: static permissible moment when two LM blocks are in close contact with each other
 Total block length L : The total block length L shown in the table is the length with the dust proof parts, code UU or SS. If other contamination protection accessories or lubricant equipment are installed, the total block length will increase. (See **A1-472** or **A1-492**)

Model number coding

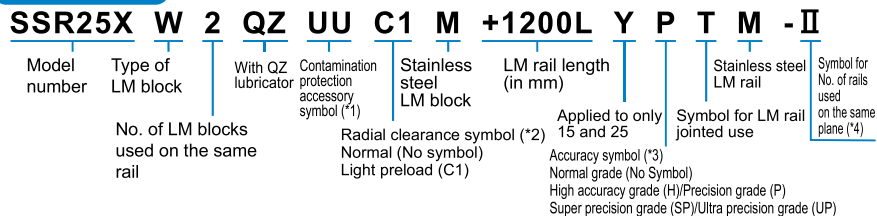

(*1) See contamination protection accessory on **A1-496**. (*2) See **A1-70**. (*3) See **A1-76**. (*4) See **A1-13**.

Note) This model number indicates that a single-rail unit constitutes one set. (i.e., required number of sets when 2 rails are used in parallel is 2 at a minimum.) Those models equipped with QZ Lubricator cannot have a grease nipple. When desiring a grease nipple for a model attached with QZ, contact THK.

** A pilot hole for side nipples, when a grease nipple for a model equipped with LaCS or QZ Lubricator is needed. Pilot holes for side nipples are not drilled through for models other than those stated above.
 For grease nipple mount machining, contact THK.
 Note2) For models SSR15 and 25, two types of rails with different mounting hole dimensions are offered (see Table1). When replacing this model with model SR, pay attention to the mounting hole dimension of the LM rail. Contact THK for details.
 Note3) The basic load rating in the dimension table is for a load in the radial direction. Use Table7 on **A1-58** to calculate the load rating for loads in the reverse radial direction or lateral direction.

Table1 The dimension of the rail mounting hole

Model No.	Standard rail	Semi-Standard rail
SSR 15	For M4 (Symbol Y)	For M3 (No symbol)
SSR 25	For M6 (Symbol Y)	For M5 (No symbol)

Models SSR-XV and SSR-XVM

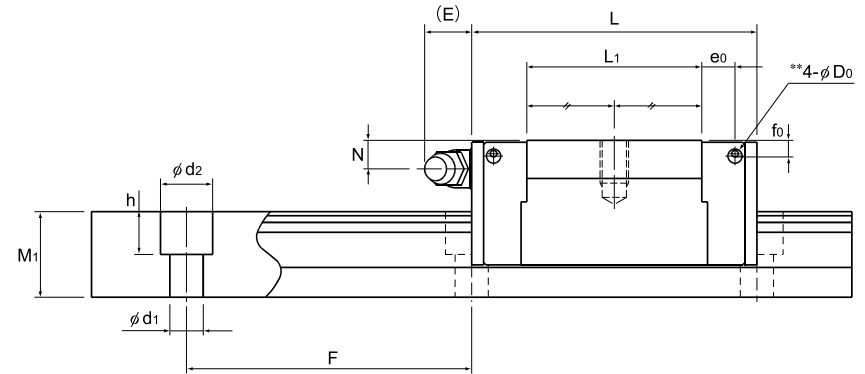
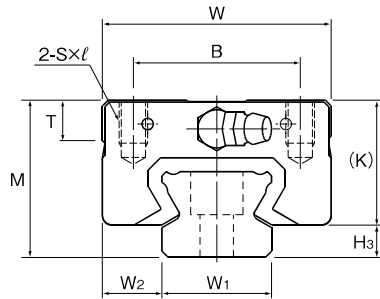

LM Guide

Unit: mm

Model No.	Outer dimensions			LM block dimensions											H ₃	LM rail dimensions					Basic load rating		Static permissible moment kN-m*					Mass		
	Height	Width	Length	B	S×ℓ	L ₁	T	K	N	E	f ₀	e ₀	D ₀	Grease nipple		Width	Height	Pitch	Length*	C	C ₀	M _A		M _B		M _C	LM block	LM rail		
	M	W	L													W ₁ ±0.05	M ₁	F	d ₁ ×d ₂ ×h	Max	kN	kN	1 block	Double blocks	1 block	Double blocks	1 block	kg	kg/m	
SSR 15XV SSR 15XVM	24	34	40.3	26	M4×7	23.3	6.5	19.5	4.5	5.5	2.7	4.5	3	PB1021B	4.5	15	9.5	12.5	60	4.5×7.5×5.3	3000 (1240)	9.1	9.7	0.0303	0.192	0.0189	0.122	0.0562	0.08	1.2
SSR 20XV SSR 20XVM	28	42	47.7	32	M5×8	27.8	8.2	22	5.5	12	2.9	5.2	3	B-M6F	6	20	11	15.5	60	6×9.5×8.5	3000 (1480)	13.4	14.4	0.0523	0.336	0.0326	0.213	0.111	0.14	2.1
SSR 25XV SSR 25XVM	33	48	60	35	M6×9	36.8	8.4	26.2	6	12	3.3	6.8	3	B-M6F	6.8	23	12.5	18	60	7×11×9	3000 (2020)	21.7	22.5	0.104	0.661	0.0652	0.419	0.204	0.23	2.7

Note) The M in the model number symbol indicates that the LM block, LM rail and balls are made of stainless steel. The stainless steel provides excellent corrosion and environmental resistance.

Note1) The maximum length under "Length*" indicates the standard maximum length of an LM rail. (See A1-114.)

Static permissible moment* 1 block: the static permissible moment with one LM block
 Double blocks: static permissible moment when two LM blocks are in close contact with each other
 Total block length L : The total block length L shown in the table is the length with the dust proof parts, code UU or SS. If other contamination protection accessories or lubricant equipment are installed, the total block length will increase. (See A1-472 or A1-492)

** A pilot hole for side nipples, when a grease nipple for a model equipped with LaCS or QZ Lubricator is needed. Pilot holes for side nipples are not drilled through for models other than those stated above. For grease nipple mount machining, contact THK.

Note2) For models SSR15 and 25, two types of rails with different mounting hole dimensions are offered (see Table1). When replacing this model with model SR, pay attention to the mounting hole dimension of the LM rail. Contact THK for details.

Note3) The basic load rating in the dimension table is for a load in the radial direction. Use Table7 on A1-58 to calculate the load rating for loads in the reverse radial direction or lateral direction.

Table1 The dimension of the rail mounting hole

Model No.	Standard rail	Semi-Standard rail
SSR 15	For M4 (Symbol Y)	For M3 (No symbol)
SSR 25	For M6 (Symbol Y)	For M5 (No symbol)

Model number coding

SSR25X V 2 QZ UU C1 M +1200L Y P T M -III

Model number	Type of LM block	With QZ lubricator	Contamination protection accessory symbol (*1)	Stainless steel LM block	LM rail length (in mm)	Stainless steel LM rail	Symbol for No. of rails used on the same plane (*4)
	No. of LM blocks used on the same rail		Radial clearance symbol (*2) Normal (No symbol) Light preload (C1)		Applied to only 15 and 25	Symbol for LM rail jointed use	
					Accuracy symbol (*3) Normal grade (No Symbol) High accuracy grade (H)/Precision grade (P) Super precision grade (SP)/Ultra precision grade (UP)		

(*1) See contamination protection accessory on A1-496. (*2) See A1-70. (*3) See A1-76. (*4) See A1-13.

Note) This model number indicates that a single-rail unit constitutes one set. (i.e., required number of sets when 3 rails are used in parallel is 3 at a minimum.) Those models equipped with QZ Lubricator cannot have a grease nipple. When desiring a grease nipple for a model attached with QZ, contact THK.

Model SSR-XTB

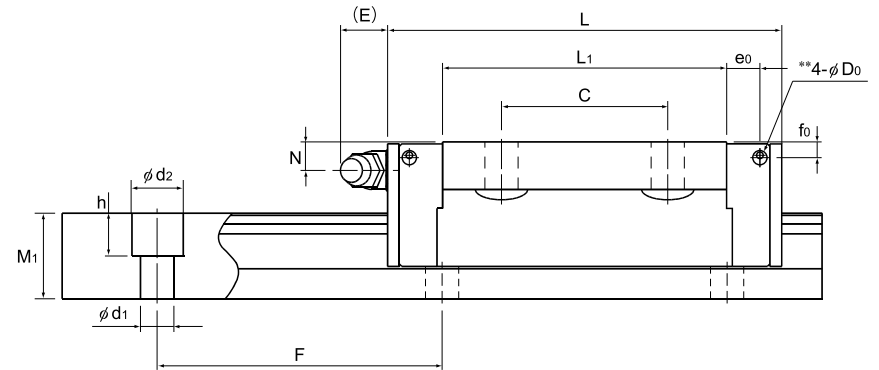
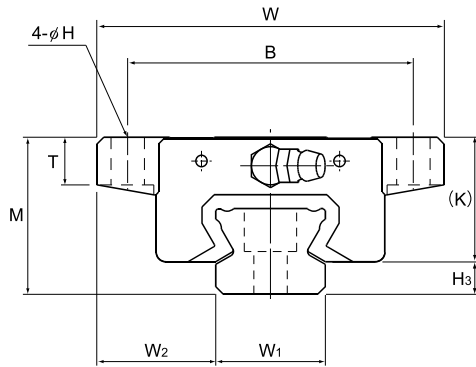

LM Guide

Unit: mm

Model No.	Outer dimensions			LM block dimensions											Grease nipple	H ₃	LM rail dimensions					Basic load rating		Static permissible moment kN-m*					Mass		
	Height	Width	Length	B	C	H	L ₁	T	K	N	E	f ₀	e ₀	D ₀			Width	Height	Pitch	Length*	C	C ₀	M _A		M _B		M _C	LM block	LM rail		
	M	W	L	±0.05	W ₂	M ₁	F	d ₁ × d ₂ × h	Max	kN	kN	1 block	Double blocks	1 block			Double blocks	1 block	kg	kg/m											
SSR 15XTB	24	52	56.9	41	26	4.5	39.9	7	19.5	4.5	5.5	2.7	4.5	3	PB1021B	4.5	15	18.5	12.5	60	4.5 × 7.5 × 5.3	3000 (1240)	14.7	16.5	0.0792	0.44	0.0486	0.274	0.0962	0.19	1.2
SSR 20XTB	28	59	66.5	49	32	5.5	46.6	9	22	5.5	12	2.9	5.2	3	B-M6F	6	20	19.5	15.5	60	6 × 9.5 × 8.5	3000 (1480)	19.6	23.4	0.138	0.723	0.0847	0.448	0.18	0.31	2.1
SSR 25XTB	33	73	83	60	35	7	59.8	10	26.2	6	12	3.3	6.8	3	B-M6F	6.8	23	25	18	60	7 × 11 × 9	3000 (2020)	31.5	36.4	0.258	1.42	0.158	0.884	0.33	0.53	2.7

Model number coding

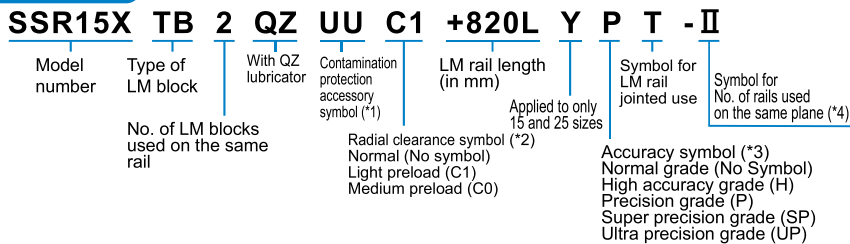

(*1) See contamination protection accessory on A1-496. (*2) See A1-70. (*3) See A1-76. (*4) See A1-13.
 Note) This model number indicates that a single-rail unit constitutes one set. (i.e., required number of sets when 2 rails are used in parallel is 2 at a minimum.)
 Those models equipped with QZ Lubricator cannot have a grease nipple. When desiring a grease nipple for a model attached with QZ, contact THK.

Note1) The maximum length under "Length*" indicates the standard maximum length of an LM rail. (See A1-114.)
 Static permissible moment* 1 block: the static permissible moment with one LM block
 Double blocks: static permissible moment when two LM blocks are in close contact with each other
 Total block length L : The total block length L shown in the table is the length with the dust proof parts, code UU or SS. If other contamination protection accessories or lubricant equipment are installed, the total block length will increase. (See A1-472 or A1-492)
 ** A pilot hole for side nipples, when a grease nipple for a model equipped with LaCS or QZ Lubricator is needed. Pilot holes for side nipples are not drilled through for models other than those stated above.
 For grease nipple mount machining, contact THK.
 Note2) For models SSR15 and 25, two types of rails with different mounting hole dimensions are offered (see Table1). When replacing this model with model SR, pay attention to the mounting hole dimension of the LM rail. Contact THK for details.
 Note3) The basic load rating in the dimension table is for a load in the radial direction. Use Table7 on A1-58 to calculate the load rating for loads in the reverse radial direction or lateral direction.

Table1 The dimension of the rail mounting hole

Model No.	Standard rail	Semi-Standard rail
SSR 15	For M4 (Symbol Y)	For M3 (No symbol)
SSR 25	For M6 (Symbol Y)	For M5 (No symbol)

Standard Length and Maximum Length of the LM Rail

Table1 shows the standard lengths and the maximum lengths of model SSR variations. If the maximum length of the desired LM rail exceeds them, jointed rails will be used. Contact THK for details. For the G dimension when a special length is required, we recommend selecting the corresponding G value from the table. The longer the G dimension is, the less stable the G area may become after installation, thus causing an adverse impact to accuracy.

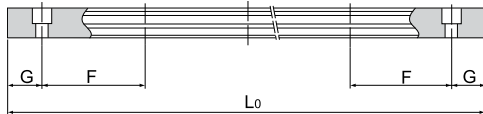

Table1 Standard Length and Maximum Length of the LM Rail Unit: mm

Model No.	SSR 15X	SSR 20X	SSR 25X	SSR 30X	SSR 35X
LM rail standard length (L ₀)	160	220	220	280	280
	220	280	280	360	360
	280	340	340	440	440
	340	400	400	520	520
	400	460	460	600	600
	460	520	520	680	680
	520	580	580	760	760
	580	640	640	840	840
	640	700	700	920	920
	700	760	760	1000	1000
	760	820	820	1080	1080
	820	940	940	1160	1160
	940	1000	1000	1240	1240
	1000	1060	1060	1320	1320
	1060	1120	1120	1400	1400
	1120	1180	1240	1480	1480
	1180	1240	1300	1640	1640
	1240	1300	1360	1720	1720
	1300	1360	1420	1800	1800
	1360	1420	1480	1880	1880
	1420	1480	1540	1960	1960
	1480	1540	1600	2040	2040
	1540	1600	1660	2120	2120
		1660	1720	2200	2200
		1720	1780	2280	2280
		1780	1840	2360	2360
		1840	1900	2440	2440
		1900	1960	2520	2520
	1960	2020	2600	2600	
	2020	2080	2680	2680	
	2080	2140	2760	2760	
	2140	2200	2840	2840	
		2260	2920	2920	
		2320			
		2380			
		2440			
Standard pitch F	60	60	60	80	80
G	20	20	20	20	20
Max length	3000 (1240)	3000 (1480)	3000 (2020)	3000 (2520)	3000

Note1) The maximum length varies with accuracy grades. Contact THK for details.
 Note2) If jointed rails are not allowed and a greater length than the maximum values above is required, contact THK.
 Note3) The figures in the parentheses indicate the maximum lengths of stainless steel made models.

Tapped-hole LM Rail Type of Model SSR

SSR model rails also include a type where the LM rail is tapped from the bottom. This type is useful when mounting from the bottom of the base and when increased contamination protection is desired.

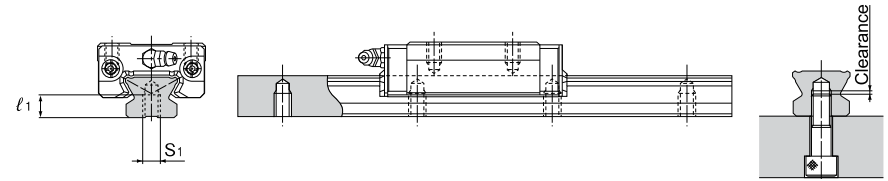

- (1) A tapped-hole LM rail type is available only for high accuracy or lower grades.
- (2) Determine the bolt length so that a clearance of 2 to 5 mm is secured between the bolt end and the bottom of the tap (effective tap depth). (See figure above.)
- (3) For standard pitches of the taps, see Table1 on **A1-114**.

Table2 Dimensions of the LM Rail Tap Unit: mm

Model No.	S ₁	Effective tap depth l ₁
SSR 15X	M5	7
SSR 20X	M6	9
SSR 25X	M6	10
SSR 30X	M8	14
SSR 35X	M8	16

Model number coding

SSR20X W2UU +1200LH K

Symbol for tapped-hole LM rail t